

SHEET	CONTENTS
1	General Notes
2	Definitions Temporary Traffic Control Devices Pedestrian and Bicyclist Overhead Work Railroads Sight Distance Above Ground Hazard
3	Clear Zone Widths For Work Zones Superelevation Length Of Lane Closures Overweight/Oversize Vehicles Lane Widths High-Visibility Safety Apparel Regulatory Speeds In Work Zones
4	Flagger Control Survey Work Zones Signs
5	Work Zone Sign Supports
6	Project Information Sign
7	Commonly Used Warning and Regulatory Signs In Work Zones
8	Manholes/Crosswalks/Joints Truck Mounted Attenuators Removing Pavement Markings Signals Channelizing Devices Channelizing Devices Consistency Portable Changeable (Variable) Message Signs (PCMS) Advanced Warning Arrow Boards
9	Drop-Offs In Work Zones
10	Business Entrance Temporary Asphalt Separator
11	Channelizing Devices Notes Temporary Barrier Notes
12	Pavement Markings

### GENERAL NOTES:

- All projects and works on highways, roads and streets shall have a traffic control plan. All work shall be executed under the established plan and Department-approved procedures. This Index contains information specific to the Federal and State guidelines and standards for the preparation of traffic control plans and for the execution of traffic control in work zones, for construction and maintenance operations and utility work on highways, roads and streets on the State Highway System. Certain requirements in this Index are based on the high volume nature of State Highways. For highways, roads and streets off the State Highway System, the local agency (City/County) having jurisdiction may adopt requirements based on the minimum requirements provided in the MUTCD.
- Indexes 102-601 through 102-670 are Department-specific typical applications of commonly encountered situations. Adjust device location or number thereof as recommended by the Worksite Traffic Supervisor and approved by the Engineer. Devices include, but are not limited to, Flaggers, portable temporary signals, signs, pavement markings, and channelizing devices. Comply with MUTCD or applicable Department criteria for any changes and document the reason for the change.
- Except for emergencies, any road closure on State Highway System shall comply with Section 335.15, F.S.

10/25/2018 8:44:35 AM

## DEFINITIONS

### Regulatory Speed (In Work Zones)

The maximum permitted travel speed posted for the work zone is indicated by the regulatory speed limit signs. The work zone speed must be shown or noted in the plans. This speed should be used as the minimum design speed to determine runoff lengths, departure rates, flare rates, lengths of need, clear zone widths, taper lengths, crash cushion requirements, marker spacings, superelevation and other similar features.

### Advisory Speed

The maximum recommended travel speed through a curve or a hazardous area.

### Travel Way

The portion of the roadway for the movement of vehicles. For traffic control through work zones, travel way may include the temporary use of shoulders and any other permanent or temporary surface intended for use as a lane for the movement of vehicular traffic.

- a. **Travel Lane:** The designated widths of roadway pavement marked to carry through traffic and to separate it from opposing traffic or traffic occupying other traffic lanes.
- b. **Auxiliary Lane:** The designated widths of roadway pavement marked to separate speed change, turning, passing and climbing maneuvers from through traffic.

### Detour, Lane Shift, and Diversion

A detour is the redirection of traffic onto another roadway to bypass the temporary traffic control zone. A lane shift is the redirection of traffic onto a different section of the permanent pavement. A diversion is the redirection of traffic onto a temporary roadway, usually adjacent to the permanent roadway and within the limits of the right of way.

### Aboveground Hazard

An aboveground hazard is any object, material or equipment other than traffic control devices that encroaches upon the travel way or that is located within the clear zone which does not meet the Department's safety criteria, i.e., anything that is greater than 4" in height and is firm and unyielding or doesn't meet breakaway requirements.

## TEMPORARY TRAFFIC CONTROL DEVICES

All temporary traffic control devices shall be ON the Department's Approved Products List (APL). Ensure the appropriate APL number is permanently marked on the device in a readily visible location.

All temporary traffic control devices shall be removed as soon as practical when they are no longer needed. When work is suspended for short periods of time, temporary traffic control devices that are no longer appropriate shall be removed or covered.

Arrow Boards, Portable Changeable Message Signs, Radar Speed Display Trailer, Portable Regulatory Signs, and any other trailer mounted device shall be delineated with a channelizing device placed at each corner when in use and shall be moved outside the travel way and clear zone or be shielded by a barrier or crash cushion when not in use.

## PEDESTRIAN AND BICYCLIST

When an existing pedestrian way or bicycle way is located within a traffic control work zone, accommodation must be maintained and provision for the disabled must be provided.

Only approved pedestrian longitudinal channelizing devices may be used to delineate a temporary traffic control zone pedestrian walkway.

Advanced notification of sidewalk closures and marked detours shall be provided by appropriate signs.

## OVERHEAD WORK

Work is only allowed over a traffic lane when one of the following options is used:

### OPTION 1 (OVERHEAD WORK USING A MODIFIED LANE CLOSURE)

Overhead work using a modified lane closure is allowed if all of the following conditions are met:

- a. Work operation is located in a signalized intersection and limited to signals, signs, lighting and utilities.
- b. Work operations are 60 minutes or less.
- c. Speed limit is 45 mph or less.
- d. Aerial lift equipment in the work area has high-intensity, rotating, flashing, oscillating, or strobe lights operating.
- e. Aerial lift equipment is placed directly below the work area to close the lane.
- f. Traffic control devices are placed in advance of the vehicle/equipment closing the lane using a minimum 100 foot taper.
- g. Volume or complexity of the roadway may dictate additional devices, signs, flagmen and/or a traffic control officer.

### OPTION 2 (OVERHEAD WORK ABOVE AN OPEN TRAFFIC LANE)

Overhead work above a open traffic lane is allowed if all of the following conditions are met:

- a. Work operation is located on a utility pole, light pole, signal pole, or their appurtenances.
- b. Work operations are 60 minutes or less.
- c. Speed limit is 45 mph or less.
- d. No encroachment by any part of the work activities and equipment within an area bounded by 2 feet outside the edge of travel way and 18 feet high.
- e. Aerial lift equipment in the work area has high-intensity, rotating, flashing, oscillating, or strobe lights operating.
- f. Volume or complexity of the roadway may dictate additional devices, signs, flagmen and/or a traffic control officer.
- g. Adequate precautions are taken to prevent parts, tools, equipment and other objects from falling into open lanes of traffic.
- h. Other Governmental Agencies, Rail facilities, or Codes may require a greater clearance. The greater clearance required prevails as the rule.

### OPTION 3 (OVERHEAD WORK ADJACENT TO AN OPEN TRAFFIC LANE)

Overhead work adjacent to an open traffic lane is allowed if all of the following conditions are met:

- a. Work operation is located on a utility pole, light pole, signal pole, or their appurtenances.
- b. Work operations are 1 day or less.
- c. Speed limit is 45 mph or less.
- d. No encroachment by any part of the work activities and equipment within 2 foot from the edge of travel way up to 18' height.  
Above 18' in height, no encroachment by any part of the work activities and equipment over the open traffic lane (except as allowed in Option 2 for work operations of 60 minutes or less).
- e. Aerial lift equipment in the work area has high-intensity, rotating, flashing, oscillating, or strobe lights operating.
- f. Volume or complexity of the roadway may dictate additional devices, signs, flagmen and/or a traffic control officer.
- g. Adequate precautions are taken to prevent parts, tools, equipment and other objects from falling into open lanes of traffic.
- h. Other Governmental Agencies, Rail facilities, or Codes may require a greater clearance. The greater clearance required prevails as the rule.

### OPTION 4 (OVERHEAD WORK MAINTAINING TRAFFIC WITH NO ENCROACHMENT BELOW THE OVERHEAD WORK AREA)

Traffic shall be detoured, shifted, diverted or paced as to not encroach in the area directly below the overhead work operations in accordance with the appropriate index drawing or detailed in the plans. This option applies to, but not limited to, the following construction activities:

- a. Beam, girder, segment, and bent/pier cap placement.
- b. Form and falsework placement and removal.
- c. Concrete placement.
- d. Railing construction located at edge of deck.
- e. Structure demolition.

### OPTION 5 (CONDUCTOR/CABLE PULLING ABOVE AN OPEN TRAFFIC LANE)

Overhead cable and/or de-energized conductor installations initial pull to proper tension shall be done in accordance with the appropriate Index or temporary traffic control plan.

Continuous pulling operations of secured cable and/or conductors are allowed over open lane(s) of traffic with no encroachment by any part of the work activities, materials or equipment within the minimal vertical clearance above the travel way. The utility shall take precautions to ensure that pull ropes and conductors/cables at no time fall below the minimum vertical clearance.

On Limited Access facilities, a site specific temporary traffic control plan is required. The temporary traffic control plan shall include:

- a. The temporary traffic control set up for the initial pulling of the pull rope across the roadway.
- b. During pulling operations, advance warning consisting of no less than a Changeable Message Sign upstream of the work area with alternating messages, "Overhead Work Ahead" and "Be Prepared to Stop" followed by a traffic control officer and police vehicle with blue lights flashing during the pulling operation.

## RAILROADS

Railroad crossings affected by a construction project should be evaluated for traffic controls to reduce queuing on the tracks. The evaluation should include as a minimum: traffic volumes, distance from the tracks to the intersections, lane closure or taper locations, signal timing, etc.

## SIGHT DISTANCE

Tapers: Transition tapers should be obvious to drivers. If restricted sight distance is a problem (e.g., a sharp vertical or horizontal curve), the taper should begin well in advance of the view obstruction. The beginning of tapers should not be hidden behind curves.

Intersections: Traffic control devices at intersections must provide sight distances for the road user to perceive potential conflicts and to traverse the intersection safely. Construction equipment and materials shall not restrict intersection sight distance.

## ABOVEGROUND HAZARD

Aboveground hazards (see definitions) are to be considered work areas during working hours and treated with appropriate work zone traffic control procedures. During nonworking hours, all objects, materials and equipment that constitute an aboveground hazard must be stored/placed outside the travel way and clear zone or be shielded by a barrier or crash cushion.

For aboveground hazards within a work zone the clear zone required should be based on the regulatory speed posted during construction.

10/25/2018 8:44:35 AM

LAST REVISION 11/01/17	REVISION	DESCRIPTION:		<b>FY 2019-20 STANDARD PLANS</b>	<b>GENERAL INFORMATION FOR TRAFFIC CONTROL THROUGH WORK ZONES</b>	INDEX 102-600	SHEET 2 of 12
---------------------------	----------	--------------	---	--------------------------------------	---	------------------	------------------

## CLEAR ZONE WIDTHS FOR WORK ZONES

The term 'clear zone' describes the unobstructed relatively flat area, impacted by construction, extending outward from the edge of the traffic lane. The table below gives clear zone widths in work zones for medians and roadside conditions other than for roadside canals; where roadside canals are present, clear zone widths are to conform with the distances to canals as described in the FDOT Design Manual 215.2.

CLEAR ZONE WIDTHS FOR WORK ZONES		
WORK ZONE SPEED (MPH)	TRAVEL LANES & MULTILANE RAMPS (feet)	AUXILIARY LANES & SINGLE LANE RAMPS (feet)
60-70	30	18
55	24	14
45-50	18	10
30-40	14	10
ALL SPEEDS CURB & GUTTER	4' BEHIND FACE OF CURB	4' BEHIND FACE OF CURB

## SUPERELEVATION

Horizontal curves constructed in conjunction with work zone traffic control should have the required superelevation applied to the design radii. Under conditions where normal crown controls curvature, the minimum radii that can be applied are listed in the table below.

MINIMUM RADII FOR NORMAL CROWN	
WORK ZONE POSTED SPEED	MINIMUM RADIUS
MPH	feet
70	4090
65	3130
60	2400
55	1840
50	1390
45	1080
40	820
35	610
30	430
Superelevate When Smaller Radii is Used	

## LENGTH OF LANE CLOSURES

For interstates and state highways with a posted speed of 55MPH or greater, lane closures must not exceed 3 miles (includes taper, buffer, and work zone) in any given direction and must not close two consecutive interchanges.

## OVERWEIGHT/OVERSIZE VEHICLES

Restrictions to Lane Widths, Heights or Load Capacity can greatly impact the movement of over dimensioned loads. The Contractor shall notify the Engineer who in turn shall notify the State Permits Office, phone no. (850) 410-5777, at least seven calendar days in advance of implementing a maintenance of traffic plan which will impact the flow of overweight/oversized vehicles. Information provided shall include location, type of restriction (height, width or weight) and restriction time frames. When the roadway is restored to normal service the State Permits Office shall be notified immediately.

## LANE WIDTHS

Lane widths of through roadways should be maintained through work zone travel ways wherever practical. The minimum widths for work zone travel lanes shall be as follows: 11' for Interstate with at least one 12' lane provided in each direction, unless formally excepted by the Federal Highway Administration; 11' for freeways; and 10' for all other facilities.

## HIGH-VISIBILITY SAFETY APPAREL

All high-visibility safety apparel shall meet the requirements of the International Safety Equipment Association (ISEA) and the American National Standards Institute (ANSI) for "High-Visibility Safety Apparel", and labeled as ANSI/ISEA 107-2004 or newer. The apparel background (outer) material color shall be either fluorescent orange-red or fluorescent yellow-green as defined by the standard. The retroreflective material shall be orange, yellow, white, silver, yellow-green, or a fluorescent version of these colors, and shall be visible at a minimum distance of 1,000 feet. Class 3 apparel may be substituted for Class 2 apparel. Replace apparel that is not visible at 1,000 feet.

**WORKERS:** All workers within the right-of-way shall wear ANSI/ISEA Class 2 apparel. Workers operating machinery or equipment in which loose clothing could become entangled during operation shall wear fitted high-visibility safety apparel. Workers inside the bucket of a bucket truck are not required to wear high-visibility safety apparel.

**UTILITIES:** When other industry apparel safety standards require utility workers to wear apparel that is inconsistent with FDOT requirements such as NFPA, OSHA, ANSI, etc., the other standards for apparel may prevail.

**FLAGGERS:** For daytime activities, Flaggers shall wear ANSI/ISEA Class 2 apparel. For nighttime activities, Flaggers shall wear ANSI/ISEA Class 3 apparel.

## REGULATORY SPEEDS IN WORK ZONES

Traffic Control Plans (TCP's) for all projects must include specific regulatory speeds for each phase of work. This can either be the posted speed or a reduced speed. The speed shall be noted in the TCPs; this includes indicating the existing speed if no reduction is to be made. Regulatory speeds are to be uniformly established through each phase.

In general, the regulatory speed should be established to route vehicles safely through the work zone as close as to normal highway speed as possible. The regulatory speed should not be reduced more than 10 mph below the posted speed and never below the minimum statutory speed for the class of facility. When a speed reduction greater than 10 mph is imposed, the reduction is to be done in 10 mph per 500' increments.

Temporary regulatory speed signs shall be removed as soon as the conditions requiring the reduced speed no longer exist. Once the work zone regulatory speeds are removed, the regulatory speed existing prior to construction will automatically go back into effect unless new speed limit signing is provided for in the plans.

On projects with interspaced work activities, speed reductions should be located in proximity to those activities which merit a reduced speed, and not "blanketed" for the entire project. At the departure of such activities, the normal highway speed should be posted to give the motorist notice that normal speed can be resumed.

If the existing regulatory speed is to be used, consideration should be given to supplementing the existing signs when the construction work zone is between existing regulatory speed signs. For projects where the reduced speed conditions exist for greater than 1 mile in rural areas (non-interstate) and on rural or urban interstate, additional regulatory speed signs are to be placed at no more than 1 mile intervals. Engineering judgement should be used in placement of the additional signs. Locating these signs beyond ramp entrances and beyond major intersections are examples of proper placement. For urban situations (non-interstate), additional speed signs are to be placed at a maximum of 1000' apart.

When field conditions warrant speed reductions different from those shown in the TCP the contractor may submit to the project engineer for approval by the Department, a signed and sealed study to justify the need for further reducing the posted speed, or, the engineer may request the District Traffic Operations Engineer (DTOE) to investigate the need. It will not be necessary for the DTOE to issue regulations for regulatory speeds in work zones due to the revised provisions of F.S. 316.07451(2) (b). Advisory Speed plates will be used at the option of the field engineer for temporary use while processing a request to change the regulatory speed specified in the plans when deemed necessary. Advisory speed plates cannot be used alone but must be placed below the construction warning sign for which the advisory speed is required.

For additional information, refer to the FDOT Design Manual 240.

LAST REVISION 11/01/18	DESCRIPTION:	 FY 2019-20 STANDARD PLANS	GENERAL INFORMATION FOR TRAFFIC CONTROL THROUGH WORK ZONES	INDEX 102-600	SHEET 3 of 12
---------------------------	--------------	---	---	------------------	------------------

## FLAGGER CONTROL

Where flaggers are used, a FLAGGER symbol or legend sign must replace the WORKERS symbol or legend sign.

The flagger must be clearly visible to approaching traffic for a distance sufficient to permit proper response by the motorist to the flagging instructions, and to permit traffic to reduce speed or to stop as required before entering the work site. Flaggers shall be positioned to maintain maximum color contrast between the flagger's high-visibility safety apparel and equipment and the work area background.

### Hand-Signaling Devices

STOP/SLOW paddles are the primary hand-signaling device. The STOP/SLOW paddle shall have an octagonal shape on a rigid handle. If the STOP/SLOW paddle is placed on a rigid staff, the minimum length of the staff, measured from the bottom of the paddle to the end of the staff that rests on the ground, must not be less than 6 ft. STOP/SLOW paddles shall be at least 24 inches wide with letters at least 6 inches high and should be fabricated from light semirigid material. The background of the STOP face shall be red with white letters and border. The background of the SLOW face shall be orange with black letters and border. When used at night-time, the STOP/SLOW paddle shall be retroreflectorized.

Flag use is limited to immediate emergencies, intersections, and when working on the centerline or shared left turn lanes where two (2) flaggers are required and there is opposing traffic in the adjacent lanes. Flags, when used, shall be a minimum of 24 inches square, made of a good grade of red material, and securely fastened to a staff that is approximately 36 inches in length. When used at nighttime, flags shall be retroreflectorized red.

Flashlight, lantern or other lighted signal that will display a red warning light shall be used at night.

### Flagger Stations

Flagger stations shall be located far enough in advance of the work space so that approaching road users will have sufficient distance to stop before entering the work space. When used at nighttime, the flagger station shall be illuminated.

## SURVEY WORK ZONES

The SURVEY CREW AHEAD symbol or legend sign shall be the principal Advance Warning Sign used for Traffic Control Through Survey Work Zones and may replace the ROAD WORK AHEAD sign when lane closures occur, at the discretion of the Party Chief.

When Traffic Control Through Work Zones is being used for survey purposes only, the END ROAD WORK sign as called for on certain 102 Series of Indexes should be omitted.

## Survey Between Active Traffic Lanes or Shared Left Turn Lanes

The following provisions apply to Main Roadway Traffic Control Work Zones. These provisions must be adjusted by the Party Chief to fit roadway and traffic conditions when the Survey Work Zone includes intersections.

- (A) A STAY IN YOUR LANE (MOT-1-06) sign shall be added to the Advance Warning Sign sequence as the second most immediate sign from the work area.
- (B) Elevation Surveys-Cones may be used at the discretion of the Party Chief to protect prism holder and flagger(s). Cones, if used, may be placed at up to 50' intervals along the break line throughout the work zone.
- (C) Horizontal Control-With traffic flow in the same direction, cones shall be used to protect the backsight tripod and/or instrument. Cones shall be placed at the equipment, and up to 50' intervals for at least 200' towards the flow of traffic.
- (D) Horizontal Control-With traffic flow in opposite directions, cones shall be used to protect the backsight tripod and/or instrument. Cones shall be placed at the equipment, and up to 50' intervals for at least 200' in both directions towards the flow of traffic.

## SIGNS

### SIGN MATERIALS

Mesh signs and non-retroreflective vinyl signs may only be used for daylight operations. Non-retroreflective vinyl signs must meet the requirements of Specifications Section 994.

Retroreflective vinyl signs meeting the requirements of Specification Section 994 may be used for daylight or night operations not to exceed 1 day except as noted in the Indexes.

Rigid or Lightweight sign panels may be used in accordance with the vendor APL drawing for the sign stand to which they are attached.

### INTERSECTING ROAD SIGNING

Signing for the control of traffic entering and leaving work zones by way of intersecting crossroads shall be adequate to make drivers aware of work zone conditions. When Work operations exceed 60 minutes, place the ROAD WORK AHEAD sign on the side street entering the work zone.

### ADJOINING AND/OR OVERLAPPING WORK ZONE SIGNING

Adjoining work zones may not have sufficient spacing for standard placement of signs and other traffic control devices in their advance warning areas or in some cases other areas within their traffic control zones. Where such restraints or conflicts occur or are likely to occur, one of the following methods will be employed to avoid conflicts and prevent conditions that could lead to misunderstanding on the part of the traveling public as to the intended travel way by the traffic control procedure applied:

- (A) For scheduled projects the engineer in responsible charge of project design will resolve anticipated work zone conflicts during the development of the project traffic control plan. This may entail revision of plans on preceding projects and coordination of plans on concurrent projects.
- (B) Unanticipated conflicts arising between adjoining in progress highway construction projects will be resolved by the Resident Engineer for projects under his residency, and, by the District Construction Engineer for in progress projects under adjoining residencies.
- (C) The District Maintenance Engineer will resolve anticipated and occurring conflicts within scheduled maintenance operations.
- (D) The Unit Maintenance Engineer will resolve conflicts that occur within routine maintenance works; between routine maintenance work, unscheduled work and/or permitted work; and, between unit controlled maintenance works and highway construction projects.

## SIGN COVERING AND INTERMITTENT WORK STOPPAGE SIGNING

Existing or temporary traffic control signs that are no longer applicable or are inconsistent with intended travel paths shall be removed or fully covered.

Sign blanks or other available coverings must completely cover the existing sign. Rigid sign coverings shall be the same size as the sign it is covering, and bolted in a manner to prevent movement.

Sign covers are incidental to work operations and are not paid for separately.

### SIGNING FOR DETOURS, LANE SHIFTS AND DIVERSIONS

Detours should be signed clearly over their entire length so that motorists can easily determine how to return to the original roadway. The reverse curve (W1-4) warning sign should be used for the advanced warning for a lane shift. A diversion should be signed as a lane shift.

### EXTENDED DISTANCE ADVANCE WARNING SIGN

Advance Warning Signs shall be used at extended distance of one-half mile or more when limited sight distance or the nature of the obstruction may require a motorist to bring their vehicle to a stop. Extended distance Advanced Warning Signs may be required on any type roadway, but particularly be considered on multilane divided highways where vehicle speed is generally in the higher range (45 MPH or more).

### UTILITY WORK AHEAD SIGN

The UTILITY WORK AHEAD (W21-7) sign may be used as an alternate to the ROAD WORK AHEAD or the ROAD WORK XX FT (W20-1) sign for utility operations on or adjacent to a highway.

### LENGTH OF ROAD WORK SIGN

The length of road work sign (G20-1) bearing the legend ROAD WORK NEXT \_\_\_\_\_ MILES is required for all projects of more than 2 miles in length. The number of miles entered should be rounded up to the nearest mile. The sign shall be located at begin construction points.

### SPEEDING FINES DOUBLED WHEN WORKERS PRESENT SIGN

The SPEEDING FINES DOUBLED WHEN WORKERS PRESENT sign should be installed on all projects, but may be omitted if the work operation is less than 1 day. The placement should be 500 feet beyond the ROAD WORK AHEAD sign or midway to the next sign whichever is less.

### GROOVED PAVEMENT AHEAD SIGN

The GROOVED PAVEMENT AHEAD sign is required 500 feet in advance of a milled or grooved surface open to traffic. The W8-15P placard shall be used in conjunction with the GROOVED PAVEMENT AHEAD sign.

### END ROAD WORK SIGN

The END ROAD WORK sign (G20-2) should be installed on all projects, but may be omitted where the work operation is less than 1 day. The sign should be placed approximately 500 feet beyond the end of a construction or maintenance project unless other distance is called for in the plans. When other Construction or Maintenance Operations occur within 1 mile this sign should be omitted and signing coordinated in accordance with Index 102-600, ADJOINING AND/OR OVERLAPPING WORK ZONE SIGNING.

### PROJECT INFORMATION SIGN

The Project information sign shall be installed when called for in the plans.

10/25/2018 8:44:37 AM

LAST REVISION 11/01/17	REVISION	DESCRIPTION:	 <b>FY 2019-20 STANDARD PLANS</b>	<b>GENERAL INFORMATION FOR TRAFFIC CONTROL THROUGH WORK ZONES</b>	INDEX <b>102-600</b>	SHEET <b>4 of 12</b>
------------------------------	----------	--------------	---	---	-------------------------	-------------------------

**TEMPORARY SIGN SUPPORT NOTES:**

- All signs shall be post mounted when work operations exceed one day except for:
  - Road closure signs mounted in accordance with the vendor drawing for the Type III Barricade shown on the APL.
  - Pedestrian advanced warning or pedestrian regulatory signs mounted on sign supports in accordance with the vendor drawing shown on the APL.
  - Median barrier mounted signs per Index 700-013.
- Unless shielded with barrier or outside of the Clear Zone, signs mounted on temporary supports or barricades, and barricade/sign combination must be crashworthy in accordance with NCHRP 350 requirements and included on the Approved Products List (APL).
- Use only approved systems listed on the Department's Approved Products List (APL).
- Manufacturers seeking approval of U-Channel and steel square tube sign support assemblies for inclusion on the Approved Products List (APL) must submit a APL application, design calculations (for square tube only), and detailed drawings showing the product meets all the requirements of this Index.
- Provide 3 lb/ft Steel U-Channel Posts with a minimum section modulus of 0.43 in<sup>3</sup> for 60 ksi steel, a minimum section modulus of 0.37 in<sup>3</sup> for 70 ksi steel, or a minimum section modulus of 0.34 in<sup>3</sup> for 80 ksi steel.
- Provide 4 lb/ft Steel U-Channel Posts with a minimum section modulus of 0.56 in<sup>3</sup> for 60 ksi steel, or a minimum section modulus of 0.47 in<sup>3</sup> for 70 ksi or 80 ksi steel.
- U-channel posts shall conform with ASTM A 499, Grade 60, or ASTM A 576, Grade 1080 (with a minimum yield strength of 60 ksi). Square tube posts shall conform with ASTM A 653, Grade 50, or ASTM A 1011, Grade 50.
- Sign attachment bolts, washers, nuts, and spacers shall conform with ASTM A307 or A 36.
- For diamond warning signs with supplement plaque (up to 5 ft<sup>2</sup> in area), use 4 lb/ft posts for up to 10 ft Clear Height (measure to the bottom of diamond warning sign).
- Install 4 lb/ft Steel U-Channel Posts with approved breakaway splice in accordance with the manufacturer's detail shown on the APL.
- The contractor may install 3 lb/ft Steel U-Channel Posts with approved breakaway splice in accordance with the manufacturer's detail shown on the APL.
- Install all posts plumb.
- The contractor may set posts in preformed holes to the specified depth with suitable backfill tamped securely on all sides, or drive 3 lb/ft sign posts and any size base post in accordance with the manufacturer's detail shown on the APL.

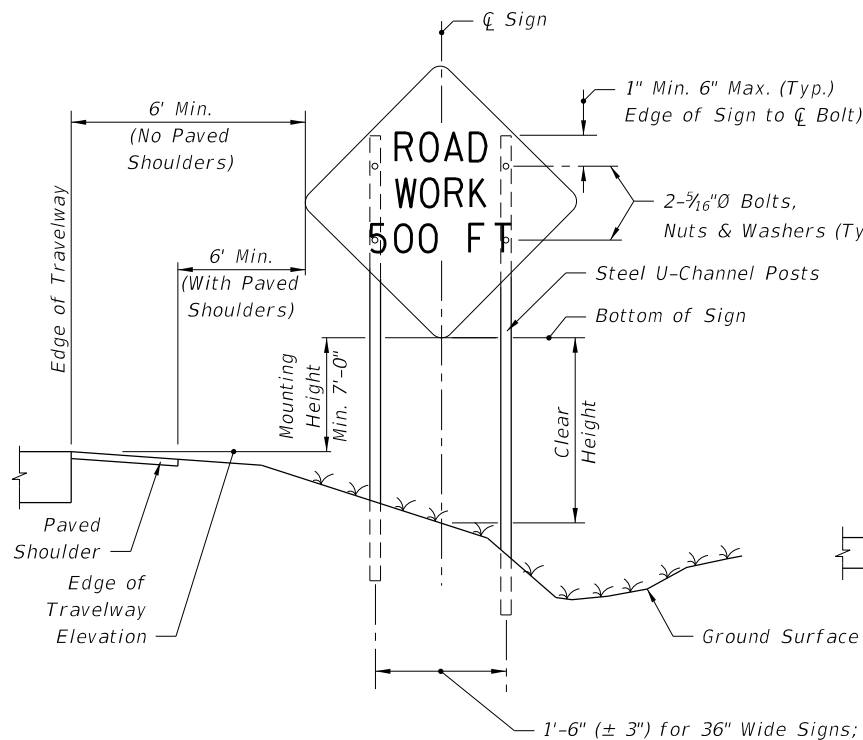

**2 POST SIGN SUPPORT MOUNTING DETAILS  
(SINGLE POST SIMILAR)  
RURAL**

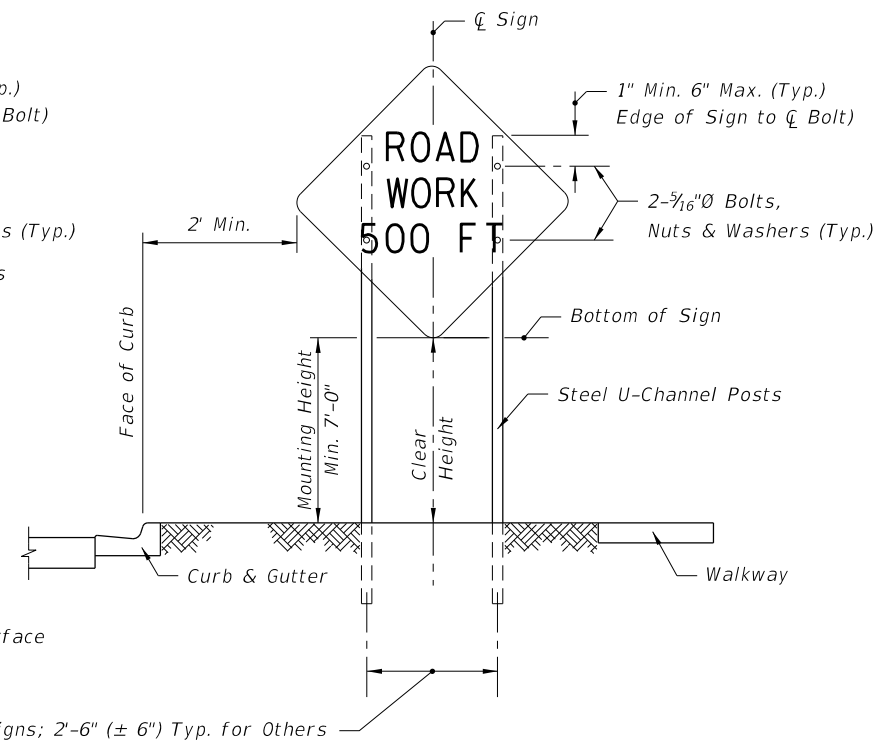

**2 POST SIGN SUPPORT MOUNTING DETAILS  
(SINGLE POST SIMILAR)  
URBAN**

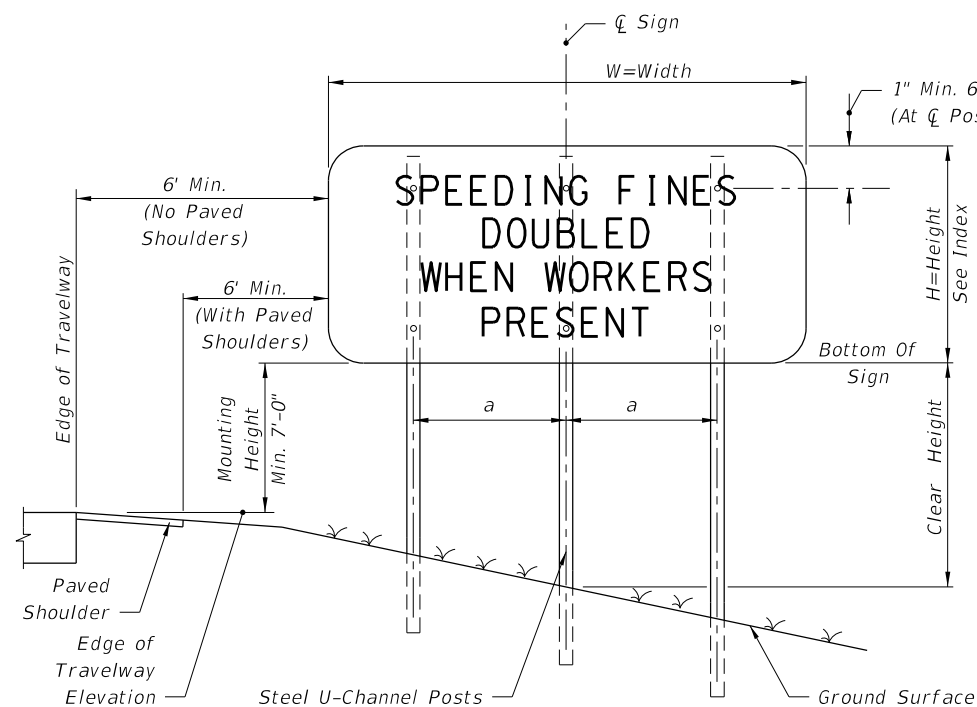

**3 POST SIGN SUPPORT MOUNTING DETAILS**

Where  $W = 48"$ :  $a = 1' - 4\frac{1}{2}" (\pm 1")$   
 $W = 60"$ :  $a = 1' - 9" (\pm 1")$   
 $W = 72"$ :  $a = 2' - 1" (\pm 1")$

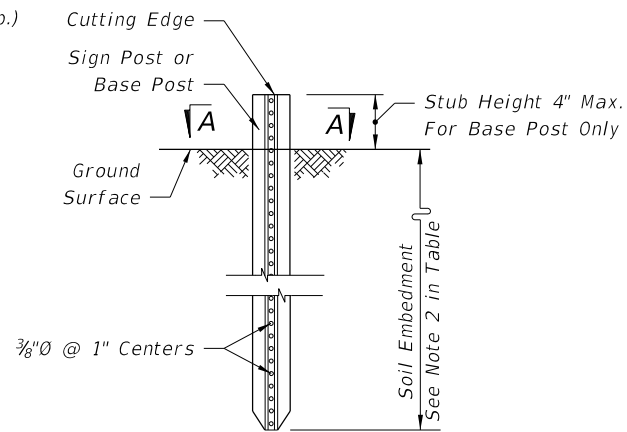

**TYPICAL FOUNDATION DETAIL**

See APL for post, splice and connection details.  
No bolts installed closer than 1" to cutting edge.

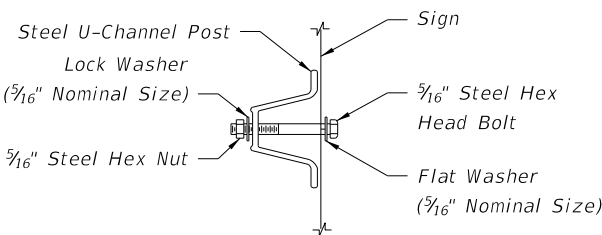

**SECTION A-A  
(SCHEMATIC)**

**SIGN ATTACHMENT DETAIL  
(WITHOUT Z-BRACKET)**

POST AND FOUNDATION TABLE FOR WORK ZONE SIGNS		
SIGN SHAPE	SIGN SIZE (inches)	NUMBER OF STEEL U CHANNEL POSTS
Octagon	30x30	1
	36x36x36	1
	48x48x48	1
Triangle	60x60x60	2
	24x18	1
	24x30	1
Rectangle (W x H)	30x24	1
	36x18	1
	36x24	1
	48x18	1
	48x24	1
	36x48	2
	48x30	2
	48x36	2
	54x36	2
	48x60	3
	60x54	3
	72x48	3
	120x60*	4*
Square	30x30	1
	36x36	2
	48x48	2
Diamond (See Note 7)	48x48	2
Circle	360	2

Notes For Table:

- Use 3 lb/ft posts for Clear Height up to 10' and 4 lb/ft posts for Clear Height up to 12'.
- \* Use 4 lb/ft U-channel sign post with a mounting height of 7' min. and 8' max. Attach sign panel using Z-bracket detail on Sheet 6.
- Minimum foundation depth is 4.0' for 3 lb/ft posts and 4.5' for 4 lb/ft posts.
- For both 3 lb/ft and 4 lb/ft base or sign posts installed in rock, a minimum cumulative depth of 2' of rock layer is required.
- The soil plate as shown on the APL vendor drawing is not required for base posts or sign posts installed in existing rock (as defined in Note 3), asphalt roadway, shoulder pavement or soil under sidewalk.

**WORK ZONE SIGN SUPPORTS**

10/25/2018 8:44:37 AM

LAST REVISION 11/01/18	DESCRIPTION:	FDOT	FY 2019-20 STANDARD PLANS	GENERAL INFORMATION FOR TRAFFIC CONTROL THROUGH WORK ZONES	INDEX 102-600	SHEET 5 of 12
---------------------------	--------------	------	------------------------------	--	------------------	------------------

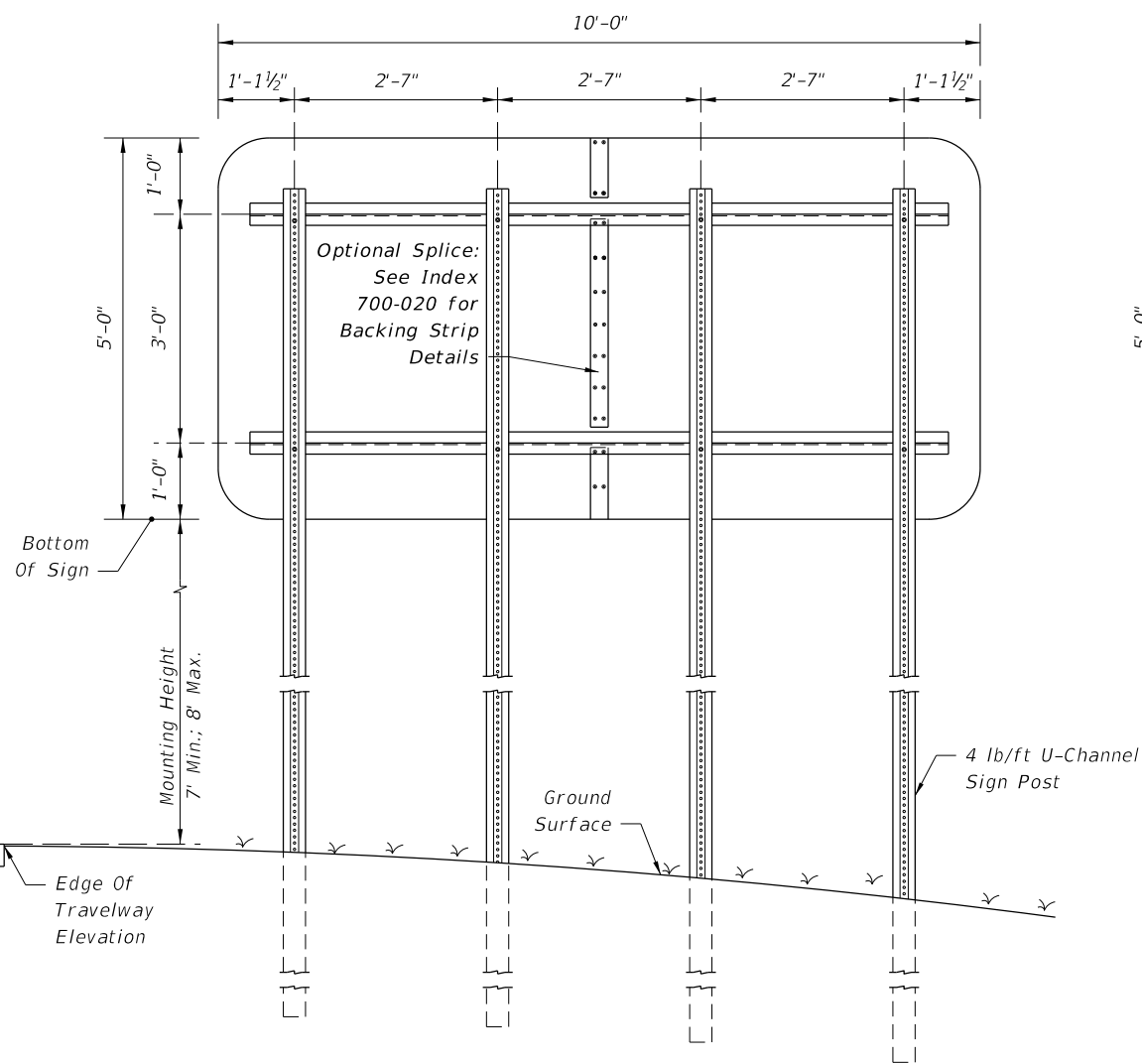

4 POST SIGN SUPPORT MOUNTING DETAIL

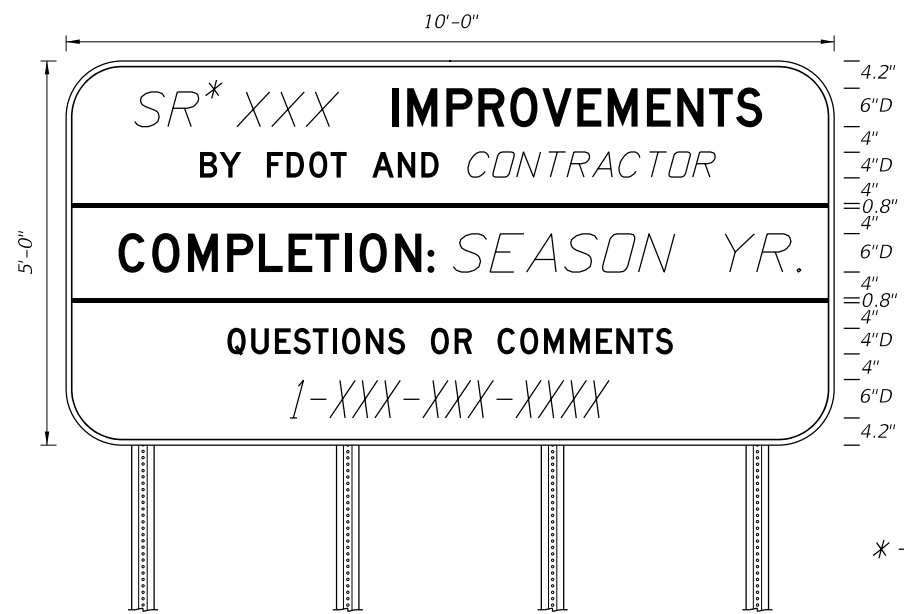

BORDER 10'-0" x 5'-0"  
 R=8" 8" Radii  
 TH=0.25" 4" and 6" series D Legend  
 IN=0.75" Blue Background  
 White Legend and Border

PROJECT INFORMATION SIGN DETAIL  
 50 MPH OR GREATER  
 Use SIGN ATTACHMENT DETAIL  
 (WITH Z-BRACKET).

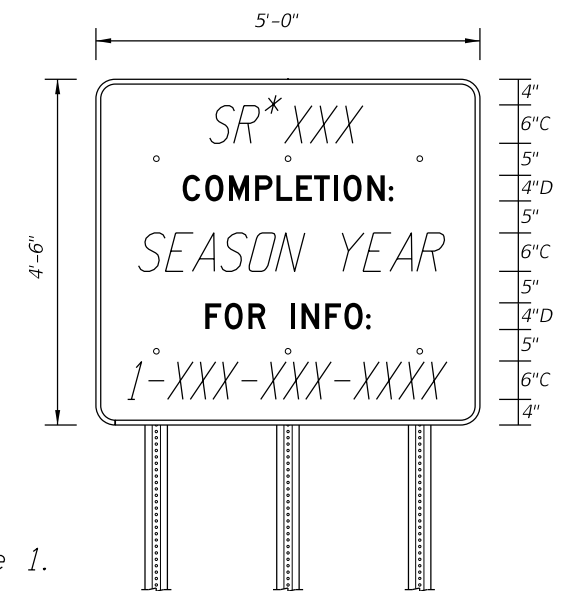

BORDER 5'-0" x 4'-6"  
 R=3" 3" Radii  
 TH=0.25" 4" series D Legend and  
 6" series C Legend  
 IN=0.75" Blue Background  
 White Legend and Border

PROJECT INFORMATION SIGN DETAIL  
 45 MPH OR LESS  
 Use SIGN ATTACHMENT DETAIL  
 (WITHOUT Z-BRACKET)  
 On Sheet 5.

\*-See Note 1.

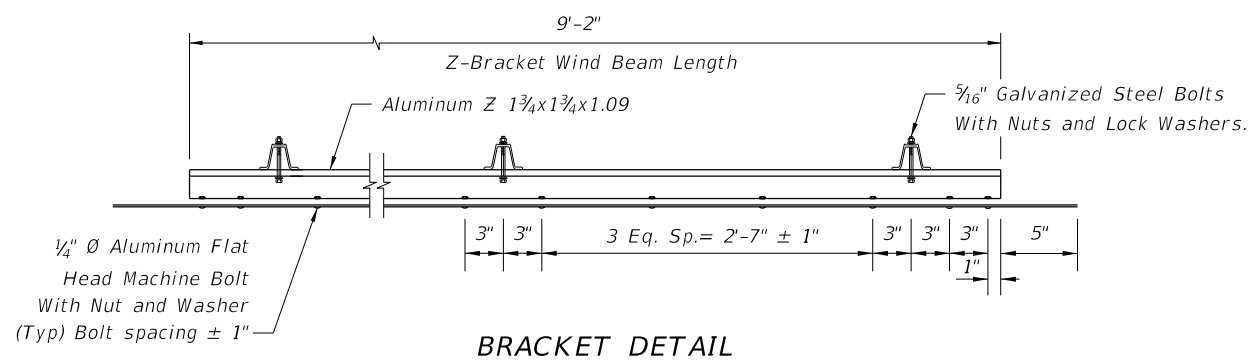

BRACKET DETAIL

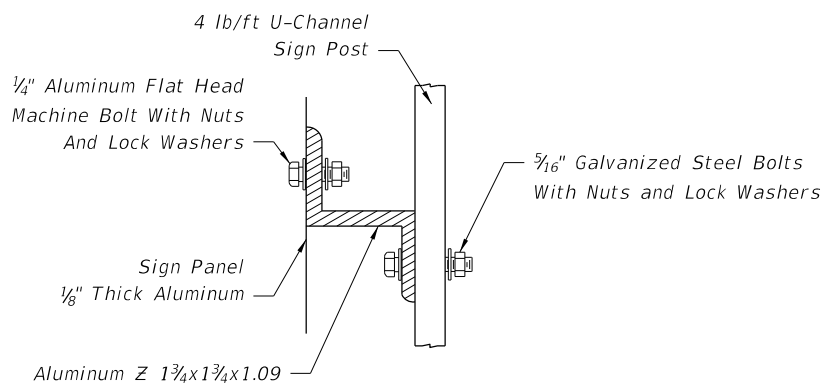

SIGN ATTACHMENT DETAIL  
 (WITH Z-BRACKET)

PROJECT INFORMATION SIGN NOTES:

1. Road designation should be the most common designation (i.e. I-Interstate, SR-State Road or US.)
2. Italic text on signs indicate variable information specific to the project.
3. See Sheet 5 for Typical Foundation Details and Post and Foundations Table.

PROJECT INFORMATION SIGN

7/24/2019 2:06:23 PM

LAST REVISION 11/01/17	DESCRIPTION:	FDOT FY 2019-20 STANDARD PLANS	GENERAL INFORMATION FOR TRAFFIC CONTROL THROUGH WORK ZONES	INDEX 102-600	SHEET 6 of 12
---------------------------	--------------	--------------------------------------	--	------------------	------------------

10/25/2018 8:44:40 AM

E5-2 B/O	E5-2a B/O	G20-1 B/O	G20-2 B/O	G20-4 B/O	M4-8 B/O	M4-8A B/O	M4-9L B/O	M4-9R B/O	M4-10L O/B	M4-10R O/B	OM-3R B/Y	R1-1 W/R	R1-2 RW/R	R2-1 B/W	R4-1 B/W	R4-2 B/W	R4-5 B/W	R4-7 B/W	R4-8 B/W	R4-7AL B/W
R4-7AR B/W	R4-7BL B/W	R4-7BR B/W	R5-1 WR/W	R9-8 B/W	R9-9 B/W	R9-10 B/W	R9-11 B/W	R9-11a B/W	R11-2 B/W	W1-1R B/O	W1-2R B/O	W1-3R B/O	W1-4R B/O	W1-4b B/O	W1-4c B/O	W1-6 B/O	W1-7 B/O	W1-8 B/O	W3-1 RB/O	W3-2 RB/O
W3-3 B(RYG)/O	W3-4 B/O	W3-5 B/O	W4-1 B/O	W4-2 B/O	W5-1 B/O	W5-2 B/O	W5-3 B/O	W6-1 B/O	W6-2 B/O	W6-3 B/O	W8-1 B/O	W8-2 B/O	W8-3 B/O	W8-4 B/O	W8-5 B/O	W8-6 B/O	W8-7 B/O	W8-8 B/O	W8-9 B/O	W8-9a B/O
W8-11 B/O	W9-1L B/O	W9-1R B/O	W9-2L B/O	W9-2R B/O	W10-1 B/Y	W11-2 B/O	W12-1 B/O	W12-2 B/O	W13-1 B/O	W20-1A B/O	W20-1B B/O	W20-1C B/O	W20-1D B/O	W20-1E B/O	W20-1F B/O	W20-2A B/O	W20-2B B/O	W20-2C B/O	W20-2D B/O	W20-2E B/O
W20-3 B/O	W20-4 B/O	W20-5a B/O	W20-5L B/O	W20-5R B/O	W20-5C B/O	W20-7A B/O	W20-7 B/O	W21-1A B/O	W21-1 B/O	W21-5 B/O	W21-5a B/O	W21-6 B/O	W21-7 B/O							
W22-1 B/O	W22-2 B/O	W22-3 B/O																		
																	<p><b>Notes:</b></p> <ol style="list-style-type: none"> <li>The size of diamond shaped Temporary Traffic Control (TTC) warning signs shall be a minimum of 48" X 48".</li> <li>Fluorescent orange shall be used for all orange colored work zone signs.</li> <li>The sign shields, symbols and messages contained on this sheet are provided for ready reference to those signs used in the development of the 102 Series of Indexes and are commonly used in the development of traffic control plans. For additional signs and sign detail information refer to the STANDARD HIGHWAY SIGNS MANUAL as specified in the MUTCD. Special signs for traffic control plans will be as approved by the State Traffic Plans Engineer.</li> </ol> <p>The sign codes shown on this sheet are for the purpose of identifying cell names found in the Traffic Control Cell Library (TCZ.Cel).</p> <p>The STANDARD HIGHWAY SIGNS MANUAL should be referenced for the official sign codes for use in the development of traffic control plans.</p> <p>See Index 700-102 for MOT sign details.</p>			
																	<p><b>COLOR CODES</b> Legend and/or Symbol Background</p> <p>O-Orange (Reflectorized)      R-Red (Reflectorized)        B-Black (Non-Reflectorized)      Y-Yellow (Reflectorized)        W-White (Reflectorized)      G-Green (Reflectorized)</p>			
MOT-1-06 B/O	MOT-4-06 B/O	MOT-5-06 B/O	MOT-7-06 B/O	MOT-8-06 B/O	MOT-9-06 B/O	MOT-10-06 B/O	MOT-11-06 BLUE/W	MOT-12-06R B/W	MOT-12-06L B/W	MOT-13-06 (Limited access facilities)	MOT-14-06 (All other facilities)	MOT-15-06 B/O	MOT-16-06 B/O	MOT-17-06 B/O	MOT-18-10 B/O					

### COMMONLY USED WARNING AND REGULATORY SIGNS IN WORK ZONES

LAST REVISION 11/01/17	REVISION	DESCRIPTION:		FY 2019-20 STANDARD PLANS	GENERAL INFORMATION FOR TRAFFIC CONTROL THROUGH WORK ZONES	INDEX 102-600	SHEET 7 of 12
---------------------------	----------	--------------	--	------------------------------	--	------------------	------------------



## MANHOLES/CROSSWALKS/JOINTS

Manholes extending 1" or more above the travel lane and crosswalks having an uneven surface greater than 1/4" shall have a temporary asphalt apron constructed as shown in the diagram below.

All transverse joints that have a difference in elevation of 1" or more shall have a temporary asphalt apron constructed as shown in the diagram below.

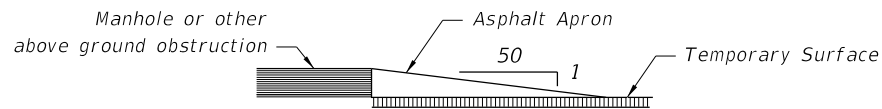

The apron is to be removed prior to constructing the next lift of asphalt. The cost of the temporary asphalt shall be included in the contract unit price for Maintenance of Traffic, LS.

## REMOVING PAVEMENT MARKINGS

Existing pavement markings that conflict with temporary work zone delineation shall be removed by any method approved by the Engineer, where operations exceed one daylight period. Remove conflicting pavement marking using a method that will not damage the surface texture of the pavement, unless the pavement will be restored prior to traffic use. Painting over existing pavement markings with black paint or spraying with asphalt shall not be accepted as substitute for removal or obliteration. Full pavement width overlays of either a structural or friction course (non-final surface) are an acceptable alternate means to achieve removal.

## SIGNALS

Existing traffic signal operations that require modification in order to carry out work zone traffic control shall be included in the TCP and be approved by the District Traffic Operations Engineer.

Maintain all existing actuated or traffic responsive mode signal operations for main and side street movements for the duration of the Contract and require restoration of any loss of detection within 12 hours. The contractor shall select only detection technology listed on the Department's Approved Products List (APL) and approved by the Engineer to restore detection capabilities.

## ADVANCE WARNING ARROW BOARDS

An arrow board in the arrow or chevron mode shall be used only for stationary or moving lane closures on multilane roadways.

For shoulder work, blocking the shoulder, for roadside work near the shoulder, or for temporarily closing one lane on a two-lane, two-way roadway, an arrow board shall be used only in the caution mode.

A single arrow board shall not be used to merge traffic laterally more than one lane. When arrow boards are used to close multiple lanes, a single board shall be used at the merging taper for each closed lane.

When Advance Warning Arrow Boards are used at night, the intensity of the flashers shall be reduced during darkness when lower intensities are desirable.

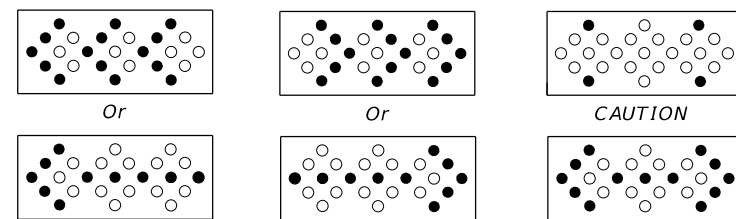

MOVE/MERGE LEFT

MOVE/MERGE RIGHT

MOVE/MERGE RIGHT OR LEFT

- Minimum Required Lamps
- Additional Lamps Allowed

### MODES

## PORTABLE CHANGEABLE MESSAGE SIGNS (PCMS)

The PCMS can be used to:

1. Supplement standard signing in construction or maintenance work zones.
2. Reinforce static advance warning messages.
3. Provide motorists with updated guidance information.

PCMS should be placed approx. 500 to 800 feet in advance of the work zone conflicts or 0.5 to 2 miles in advance of complex traffic control schemes which require new and/or unusual traffic maneuvers.

If PCMS are to be used at night, the intensity of the flashers shall be reduced during darkness when lower intensities are desirable.

For additional information refer to the FDOT Design Manual 240.

## TRUCK/TRAILER-MOUNTED ATTENUATORS

Truck/Trailer-mounted attenuators (TMA) can be used for moving operations and short-term stationary operations. For moving operations, see Indexes 102-607 and 102-619. For short-term, stationary operations, see Part VI of the MUTCD.

## CHANNELIZING DEVICES

Channelizing devices for work zone traffic control shall be as prescribed in Part VI of the MUTCD, subject to supplemental revisions provided in the contract documents and the 102 Series of Indexes. Lighting Devices must not be used to supplement channelization.

## CHANNELIZING DEVICE CONSISTENCY

Barricades, vertical panels, cones, tubular markers and drums shall not be intermixed within either the lateral transition or within the tangent alignment.

LAST REVISION 11/01/17	REVISION	DESCRIPTION:	 FY 2019-20 STANDARD PLANS	GENERAL INFORMATION FOR TRAFFIC CONTROL THROUGH WORK ZONES	INDEX 102-600	SHEET 8 of 12
---------------------------	----------	--------------	---	---	------------------	------------------



**DROP-OFF CONDITION NOTES**

1. These conditions and treatments can be applied only in work areas that fall within a properly signed work zone.
2. When drop-offs occur within the clear zone due to construction or maintenance activities, protection devices are required (See Table 1). A drop-off is defined as a drop in elevation, parallel to the adjacent travel lanes, greater than 3" with slope (A:B) steeper than 1:4. In superelevated sections, the algebraic difference in slopes should not exceed 0.25 (See Drop-off Condition Detail).
3. Drop-offs may be mitigated by placement of slopes with optional base material per Specification 285. Slopes shallower than 1:4 may be required to avoid algebraic difference in slopes greater than 0.25. Include the cost for the placement and removal of the material in Maintenance of Traffic, LSD. Use of this treatment in lieu of a temporary barrier is not eligible for CSIP consideration. Conduct daily inspections for deficiencies related to erosion, excessive slopes, rutting or other adverse conditions. Repair any deficiencies immediately.
4. For Setback Distance, refer to the Index or Approved Products List (APL) drawing of the selected barrier.
5. For Conditions 1 and 3 provided in Table 1, any drop-off condition that is created and restored within the same work period will not be subject to the use of temporary barriers; however, channelizing devices will be required.
6. When permanent curb heights are  $\geq 6"$ , no channelizing device will be required. For curb heights  $< 6"$ , see Table 1.

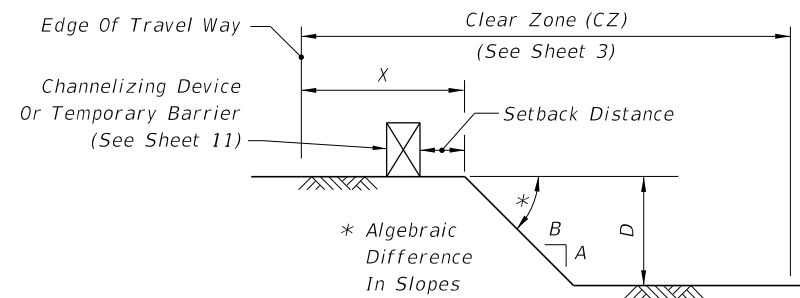

**DROP-OFF CONDITION DETAIL**

**Table 1  
Drop-off Protection Requirements**

Condition	X (ft)	D (in.)	Device Required
1	0-12	> 3	Temporary Barrier
2	> 12-CZ	> 3 to $\leq 5$	Channelizing Device
3	0-CZ	> 5	Temporary Barrier
4	Removal of Bridge or Retaining Wall Barrier		Temporary Barrier
5	Removal of portions of Bridge Deck		Temporary Barrier

**TRAVEL LANE TREATMENT FOR MILLING OR RESURFACING NOTES**

1. This treatment applies to resurfacing or milling operations between adjacent travel lanes.
2. Whenever there is a difference in elevation between adjacent travel lanes, the W8-11 sign with "UNEVEN LANES" is required at intervals of 1/2 mile maximum.
3. If D is 1 1/2" or less, no treatment is required.
4. Treatment allowed only when D is 3" or less.
5. If the slope is steeper than 1:4 (not to be steeper than 1:1), the R4-1 and MOT-1-06 signs shall be used as a supplement to the W8-11; this condition should never exceed 3 miles in length.

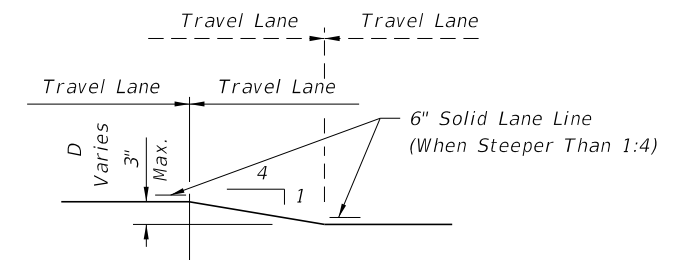

**TRAVEL LANE TREATMENT FOR MILLING OR RESURFACING DETAIL**

**PEDESTRIAN WAY DROP-OFF CONDITION NOTES**

1. A pedestrian way drop-off is defined as:
  - a. a drop in elevation greater than 10" that is closer than 2' from the edge of the pedestrian way
  - b. a slope steeper than 1:2 that begins closer than 2' from the edge of the pedestrian way when the total drop-off is greater than 60"
2. Protect any drop-off adjacent to a pedestrian way with pedestrian longitudinal channelizing devices, temporary barrier wall, or approved handrail.

**DROP-OFFS IN WORK ZONES**

1/8/2019 6:41:18 AM

LAST REVISION 11/01/18	DESCRIPTION:
---------------------------	--------------

**FY 2019-20  
STANDARD PLANS**

**GENERAL INFORMATION FOR TRAFFIC  
CONTROL THROUGH WORK ZONES**

INDEX 102-600	SHEET 9 of 12
------------------	------------------

Speed (mph)	Max. Distance Between Devices (ft.)			
	Tubular Markers		Vertical Panels or Opposing Traffic Lane Divider	
	Taper	Tangent	Taper	Tangent
25	25	50	25	50
30 to 45	25	50	30	50
50 to 70	25	50	50	100

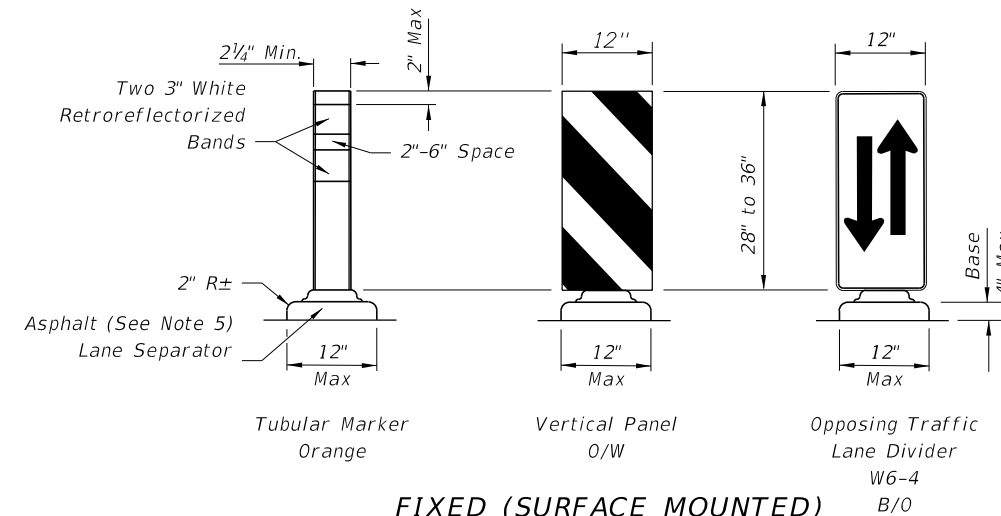
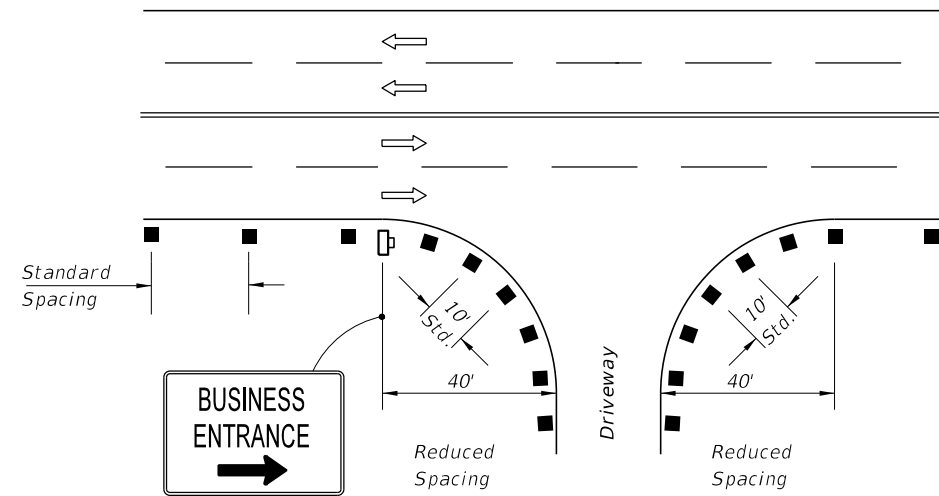
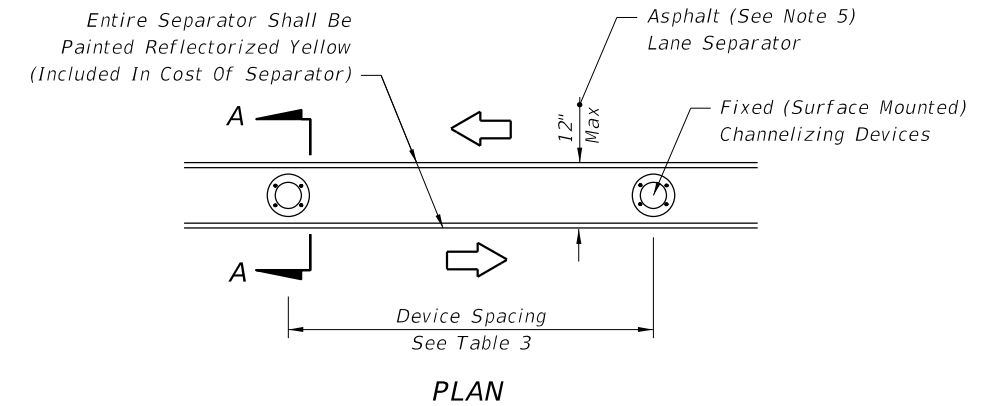

**FIXED (SURFACE MOUNTED)  
CHANNELIZING DEVICES**

**SECTION AA**

1. For single business entrances, place one 24" x 36" business sign for each driveway entrance affected. Signs shall show specific business names. Logos may be provided by business owners. Standard BUSINESS ENTRANCE sign in Index 700-102 may be used when approved by the Engineer.
2. When several businesses share a common driveway entrance, place one 24" x 36" standard BUSINESS ENTRANCE sign in accordance with Index 700-102 at the common driveway entrance.
3. Channelizing devices shall be placed at a reduced spacing on each side of the driveway entrance, but shall not restrict sight distance for the driveway users.
4. Business entrance signs are intended to guide motorist to business entrances moved/modified or disturbed during construction projects. Business entrance signs are not required where there is minimal disruption to business driveways which is often the case with resurfacing type projects.

**PLACEMENT OF BUSINESS ENTRANCE SIGNS AND  
CHANNELIZING DEVICES AT BUSINESS ENTRANCE**

1. Temporary lane separators shall be supplemented with any of the following approved fixed (surface mounted) channelizing devices: tubular markers, vertical panels, or opposing traffic lane divider panels. Opposing traffic lane divider panels (W6-4) shall only be used as center lane dividers to separate opposing vehicular traffic on a two-lane, two-way operation. Tubular Markers, Vertical Panels and Opposing Traffic Lane Divider panels shall not be intermixed within the limits where the temporary lane separator is used. The connection between the channelizing device and the temporary lane separator curb shall hold the channelizing device in a vertical position.
2. ReflectORIZED materials shall have a smooth sealed outer surface which will display the same approximate color day and night. Furnish channelizing devices having retroreflective sheeting meeting the requirements of Section 990.
3. 12" openings for drainage shall be constructed in the asphalt and portable temporary lane separator at a maximum spacing of 25' in areas with grades of 1% or less or 50' in areas with grades over 1% as directed by the Engineer.
4. Tapered ends shall be used at the beginning and end of each run of the temporary lane separator to form a gradual increase in height from the pavement level to the top of the temporary lane separator.
5. The Contractor has the option of using portable temporary lane separators containing fixed channelizing devices in lieu of the temporary asphalt separator and channelizing devices detailed on this sheet. The portable temporary lane separator shall come in portable sections that can be connected to maintain continuous alignment between the separate curb sections. Each temporary lane separator section shall be 36 inches to 48 inches in total length. Portable temporary lane separators shall duplicate the color of the pavement marking. Portable temporary lane separators shall be one of those listed on the Approved Products List.
6. Any damage to existing pavement caused by the removal of temporary lane separator shall be satisfactorily repaired and the cost of such repairs are to be included in the cost of Maintenance of Traffic, LS.

**TEMPORARY LANE SEPARATOR**

10/25/2018 8:44:42 AM

LAST REVISION 11/01/17	DESCRIPTION:	FY 2019-20 STANDARD PLANS	GENERAL INFORMATION FOR TRAFFIC CONTROL THROUGH WORK ZONES	INDEX 102-600	SHEET 10 of 12
---------------------------	--------------	------------------------------	--	------------------	-------------------

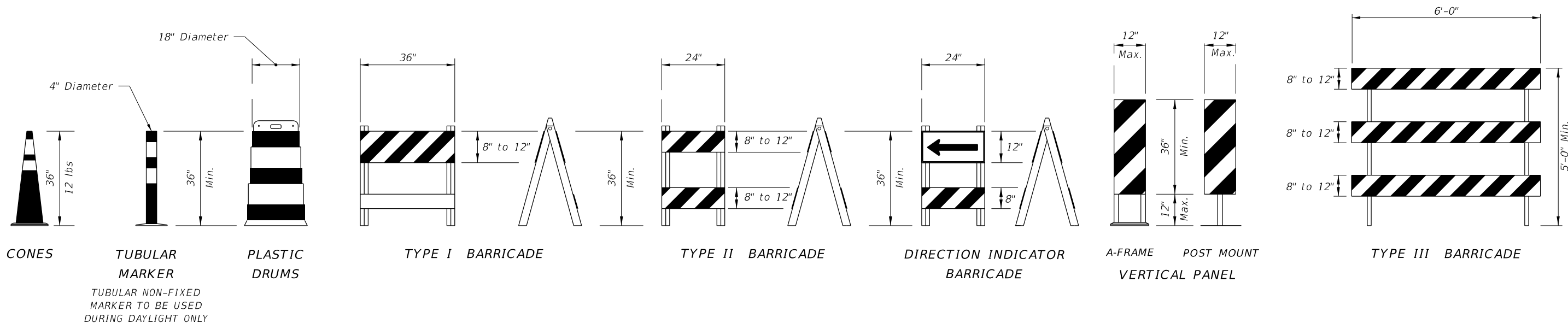

**CHANNELIZING DEVICES**

**CHANNELIZING DEVICE NOTES:**

- The details shown on this sheet are for the following purposes:
  - For ease of identification and
  - To provide information that supplements or supersedes that provided by the MUTCD.
- The Type III Barricade shall have a unit length of 6'-0" only. When barricades of greater lengths are required those lengths shall be in multiples of the 6'-0" unit.
- No sign panel should be mounted on any channelizing device unless the channelizing device/sign combination was found to be crashworthy and the sign panel is mounted in accordance with the vendor drawing for the channelizing device shown on the Approved Products List (APL).
- Ballast shall not be placed on top rails or any striped rails or higher than 13" above the driving surface.
- The direction indicator barricade may be used in tapers and transitions where specific directional guidance to drivers is necessary. If used, direction indicator barricades shall be used in series to direct the driver through the transition and into the intended travel lane.
- The splicing of sheeting is not permitted on either channelizing devices or MOT signs.
- For rails less than 3'-0" long, 4" stripes shall be used.
- Cones shall:
  - Be used only in active work zones where workers are present.
  - Be reflectorized as per the MUTCD with Department-approved reflective collars when used at night.
- Vehicular longitudinal channelizing devices shall not exceed 36" in height. For vehicular longitudinal channelizing devices (LCDs) less than 32" in height, the LCD shall be supplemented with approved fixed (surface mounted) channelizing devices (tubular markers, vertical panels, etc.) along the run of the LCD, at the ends, at 50' centers on tangents, and 25' centers on radii. The cost of the fixed supplemented channelizing devices shall be included in the cost of the LCD. LCDs less than 32" in height shall not be used for speeds greater than 45 mph.

10. For pedestrian longitudinal channelizing devices, the device shall have a minimum of 8" continuous detectable edging above the walkway. A gap not exceeding a height of 2" is allowed to facilitate drainage. The top surface of the device shall be a minimum height of 32" and have a 1/8" or less difference in any plane at all connection points between the devices to facilitate hand trailing. The bottom and the top surface of the device shall be in the same vertical plane. If pedestrian drop-off protection is required, the device shall have a footprint or offset of at least 2', otherwise the device must be at least 42" in height above the walkway and be anchored or ballasted to withstand a 200 lb lateral point load at the top of the device.

11. For Barrier Delineators, see Specification 102. Place on top of unit so that retroreflective sheeting faces vehicular traffic. Color must match adjacent longitudinal pavement marking.

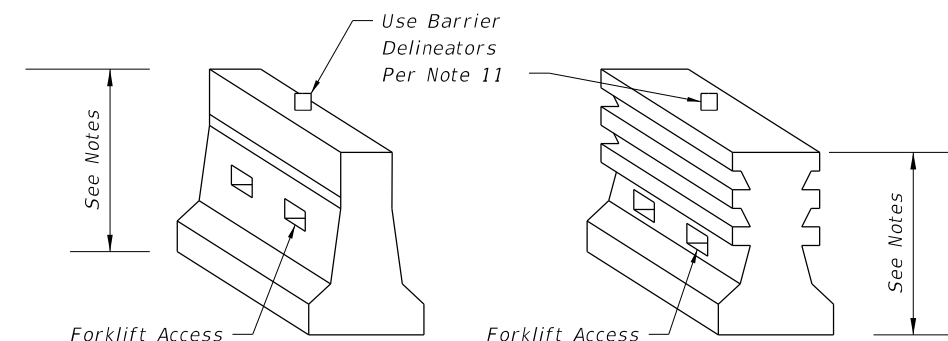

**TEMPORARY BARRIER NOTES:**

1. Where a barrier is specified, any of the types below may be used in accordance with the applicable Index:

Index	Description
102-100	Temporary Barrier
102-120	Low Profile Barrier
536-001	Guardrail

2. Trailer Mounted Barriers may be used to provide positive protection for workers within the work areas. APL drawings may be used as a guide to develop project specific Temporary Traffic Control Plans that are signed and sealed by the Contractor's Engineer.

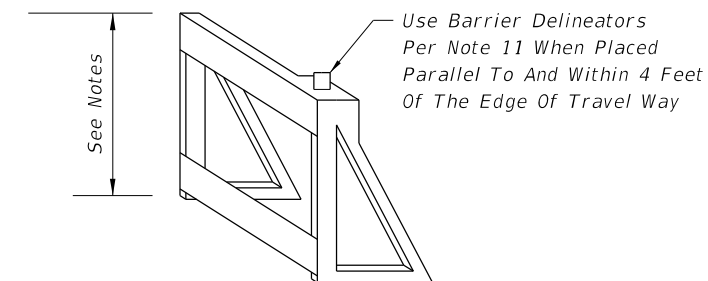

**LONGITUDINAL CHANNELIZING DEVICE**

1/30/2019 9:15:45 AM

LAST REVISION 11/01/17	DESCRIPTION:		FY 2019-20 STANDARD PLANS	GENERAL INFORMATION FOR TRAFFIC CONTROL THROUGH WORK ZONES	INDEX 102-600	SHEET 11 of 12
---------------------------	--------------	--	------------------------------	--	------------------	-------------------

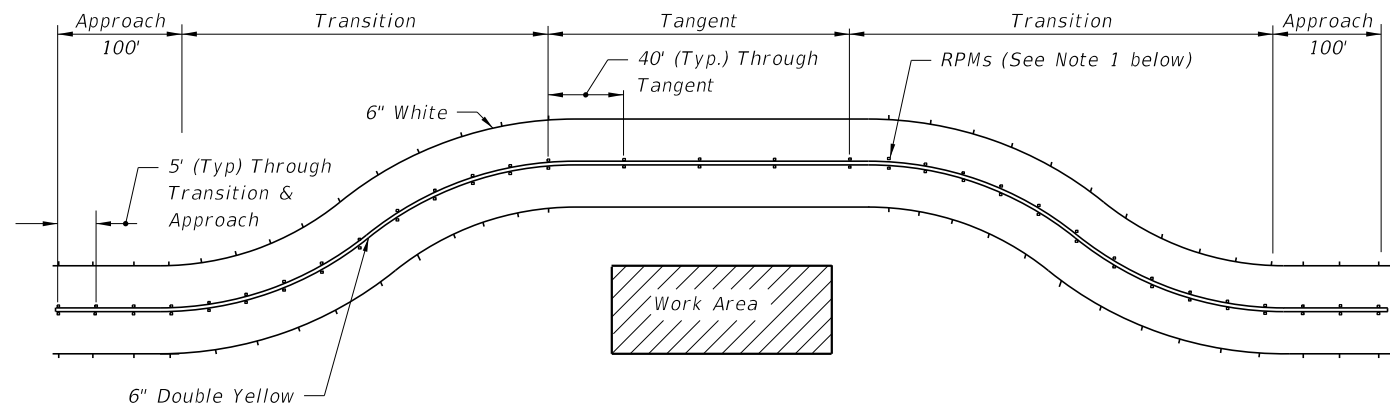

**USE OF RPMS TO SUPPLEMENT PAINT OR REMOVABLE TAPE IN WORK ZONES**

1. RPMS shall be installed as a supplement to:
  - a. All lane lines.
  - b. Edge lines in transition & approach areas.
  - c. Edge lines of gore areas.
2. Placement of RPMS should be as shown in Index 706-001 with the following exceptions:
  - RPMS shall be placed at 5 feet center to center in approach and transition areas.

**NOTES FOR RAISED PAVEMENT MARKERS:**

1. The color of the raised pavement marker under both day and night conditions shall conform to the color of the marking for which they serve as a positioning guide, or for which they supplement.
2. RPMS used to supplement lane lines are to be paid for as Raised Pavement Marker (Temporary), EA. RPMS used as a temporary substitute for paint or removable tape due to equipment malfunction are to be placed at the Contractor's expense.

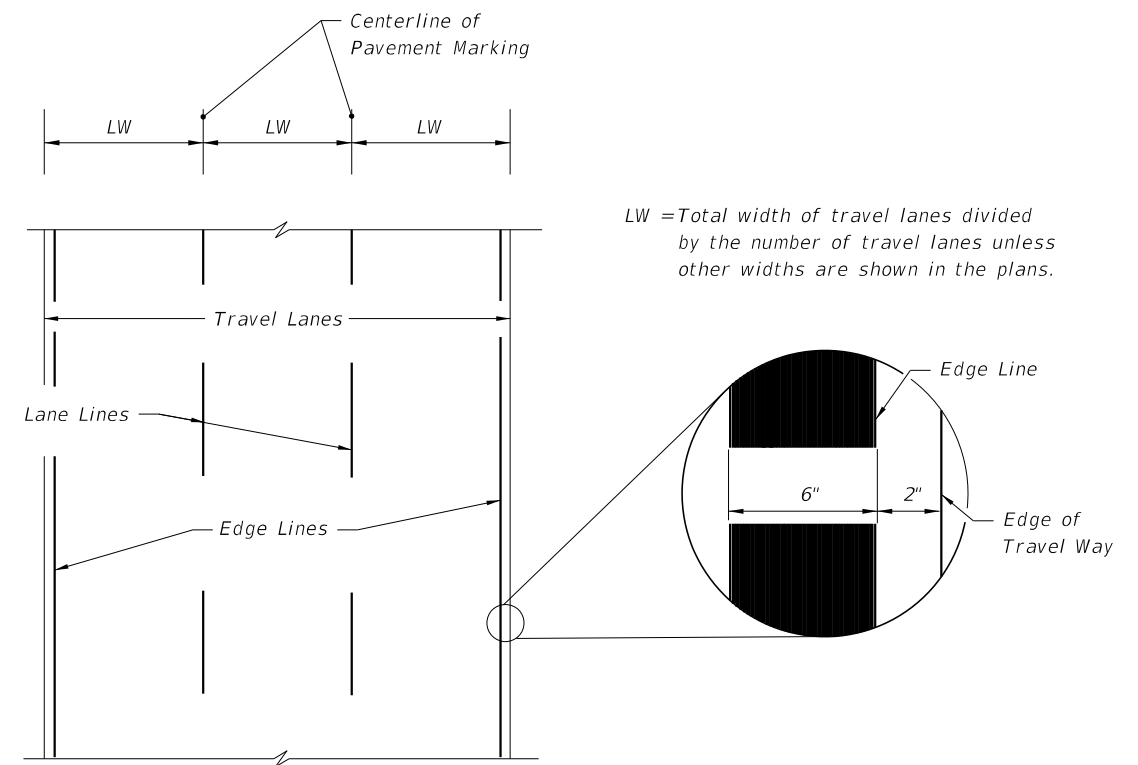

**PLACEMENT OF PAVEMENT MARKINGS**

**PAVEMENT MARKINGS**

10/25/2018 8:44:43 AM

LAST REVISION 11/01/17	REVISION	DESCRIPTION:	 FY 2019-20 STANDARD PLANS	GENERAL INFORMATION FOR TRAFFIC CONTROL THROUGH WORK ZONES	INDEX 102-600	SHEET 12 of 12
---------------------------	----------	--------------	---	---	------------------	-------------------