

GENERAL NOTES:

This Index is only applicable to the current FDOT inventory of temporary bridge components which are manufactured in accordance with Acrow Series 300, Double Wide design.

Work this Index with Index 102-210, 102-220, 102-230 and 102-240.

STRUCTURAL STEEL:

*Steel Plates and Rolled Sections shall be ASTM A709 Grade 36.
Pipe piles shall be ASTM A252 Grade 2, Fy = 35 ksi.*

BOLTS, LAG SCREWS AND THREADED BOLT STOCK:

Furnish high strength bolts in accordance with ASTM F3125 Grade A325 Type 1. Furnish Threaded Stock in accordance with ASTM A36. Furnish Lag Screws in accordance with ASTM A307. Furnish steel washers and nuts compatible with Bolts, Threaded Stock and Lag Screws.

TIMBER AND LAGGING:

Timber and Lagging shall be No. 1 Southern Yellow Pine.

BACKWALL BENT PILES:

*Timber Piles:
10' Minimum Embedment into compacted backfill or into soil having a blow count greater than 6 (N>6).
Ultimate Capacity greater than 18 tons.
Splices are not allowed on any timber piles.*

H-Piles:

*12' Minimum Embedment into compacted backfill or into soil having a blow count greater than 6 (N>6).
Ultimate Capacity greater than 18 tons.*

*Shims admissible between backwall pile and cap.
Test piles are not required for backwall piles.*

EXPANSION BEARINGS:

*Inspect the PTFE (Teflon) layer and stainless steel plate prior to installation.
Do not use bearings that have a severely damaged or unbonded PTFE layer.
Clean PTFE of all grit and grime prior to installation.
Clean Stainless steel plate of all grit and grime prior to installation and finish to a smooth buffed surface.*

DISTRIBUTING BEAMS:

*Longitudinal stops restraining the distributing beams may be lengthened or shortened to center the distributing beam bearing on the cap beam.
The longitudinal stops are to bear on the distributing beam end frame.*

EXPANSION JOINT SETTINGS:

Install the expansion joint considering the total continuous bridge length, location of fixed bearings and ambient temperature at the time of installation, assume a 1" expansion joint opening at 70 degrees F.

STORAGE FACILITY:

*Contact
FDOT Statewide Aluminum Shop
2590 Camp Rd.
Oviedo, Fl.
407-278-2727
For shipping weights and dimensions of Temporary Bridge elements.*

SHIPPING WEIGHTS AND DIMENSIONS:

Decking Sizes:

Type	Length	Width	Weight (lbs.)
Curb	5'	6'-9"	800
Curb	10'	6'-9"	1420
Curb	15'	6'-9"	2200
Curb	20'	6'-9"	2800
NonCurb	5'	5'-3"	650
NonCurb	10'	5'-3"	1000
NonCurb	15'	5'-3"	1600
NonCurb	20'	5'-3"	2100

Shipping weights and dimensions of other bridge components can be referenced in "Acrow Panel Bridging, Series 300, Technical Handbook".

TRAFFIC RAILING NOTES:

See Index 536-001 for component details, geometric layouts and associated notes not fully detailed herein.

CONCRETE: *Concrete for Transition Blocks shall be Class II (Bridge Deck).*

THRIE-BEAM PANEL: *Steel Thrie-Beam Elements shall meet the requirements of AASHTO M180, Type II (Zinc coated).*

BOLTS, NUTS AND WASHERS: *Bolts, nuts and round washers shall be in accordance with AASHTO M180. Plate Washers shall be in accordance with ASTM A36 or ASTM A709 Grade 36. Do not drill Temporary Bridge components to attach Guardrail. Guardrail Bolts shall be placed between Truss members as shown in Index 102-240.*

COATINGS: *All Nuts, Bolts, Anchors, Washers and Backer Plates shall be hot-dip galvanized in accordance with the Specifications.*

WOOD BLOCKS: *All wood blocks, including required wedge shaped blocks shall be Pressure Treated Lumber in accordance with Specifications Section 955. Bolt holes in blocks to be centered (±1/4").*

PAYMENT:

Temporary Detour Bridge is to be paid for under Contract Unit Price for Special Detour. If a temporary bridge system other than that shown herein is used, the Contractor is responsible for renting or purchasing their own system. Payment for Temporary Guardrail work and Transition Block will be made under Pay Item Temporary Guardrail, LF.

Furnish and install Bridge Thrie-Beam Panels and all associated hardware as shown. Payment will be made with the Temporary Detour Bridge under the Pay Item Special Detour, LS. Turn over Bridge Thrie-Beam Panels and all associated hardware to the Department with the Detour Bridge components per Specifications Section 102-6.

10/23/2018 10:54:52 AM

LAST REVISION 11/01/18	REVISION	DESCRIPTION:	 FY 2019-20 STANDARD PLANS	TEMPORARY DETOUR BRIDGE GENERAL NOTES AND DETAILS	INDEX 102-200	SHEET 1 of 7
---------------------------	----------	--------------	---	--	-------------------------	------------------------

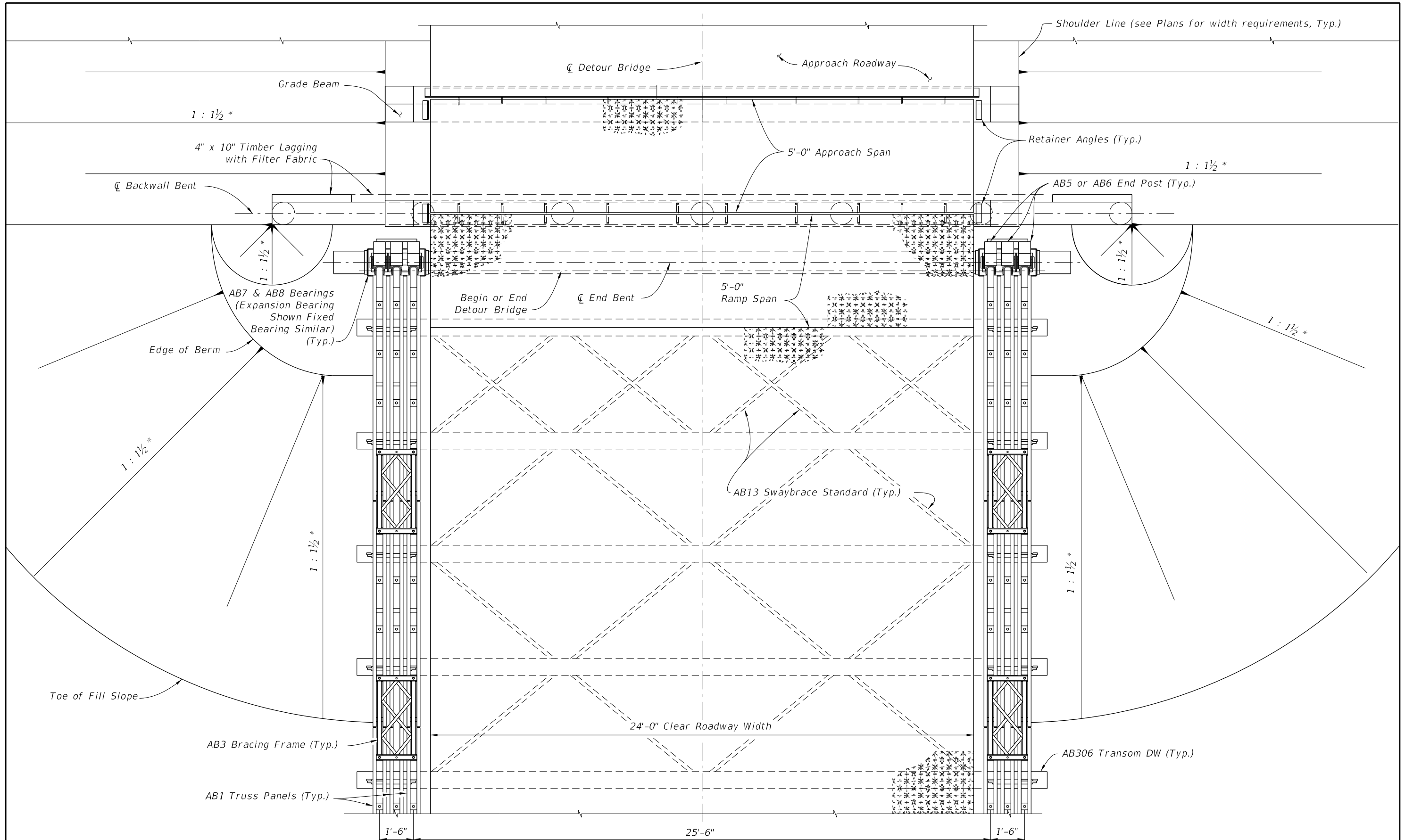

TYPICAL PLAN VIEW OF DETOUR BRIDGE
 (TIMBER PILES SHOWN, STEEL H PILES AND STEEL PIPE PILES SIMILAR)
 (Thrie-Beam Panel not shown for clarity, See Index 102-240)

* or Flatter

10/23/2018 10:54:59 AM

LAST REVISION 07/01/15	REVISION	DESCRIPTION:	 FY 2019-20 STANDARD PLANS	TEMPORARY DETOUR BRIDGE GENERAL NOTES AND DETAILS	INDEX 102-200	SHEET 2 of 7
------------------------------	----------	--------------	--	--	------------------	-----------------

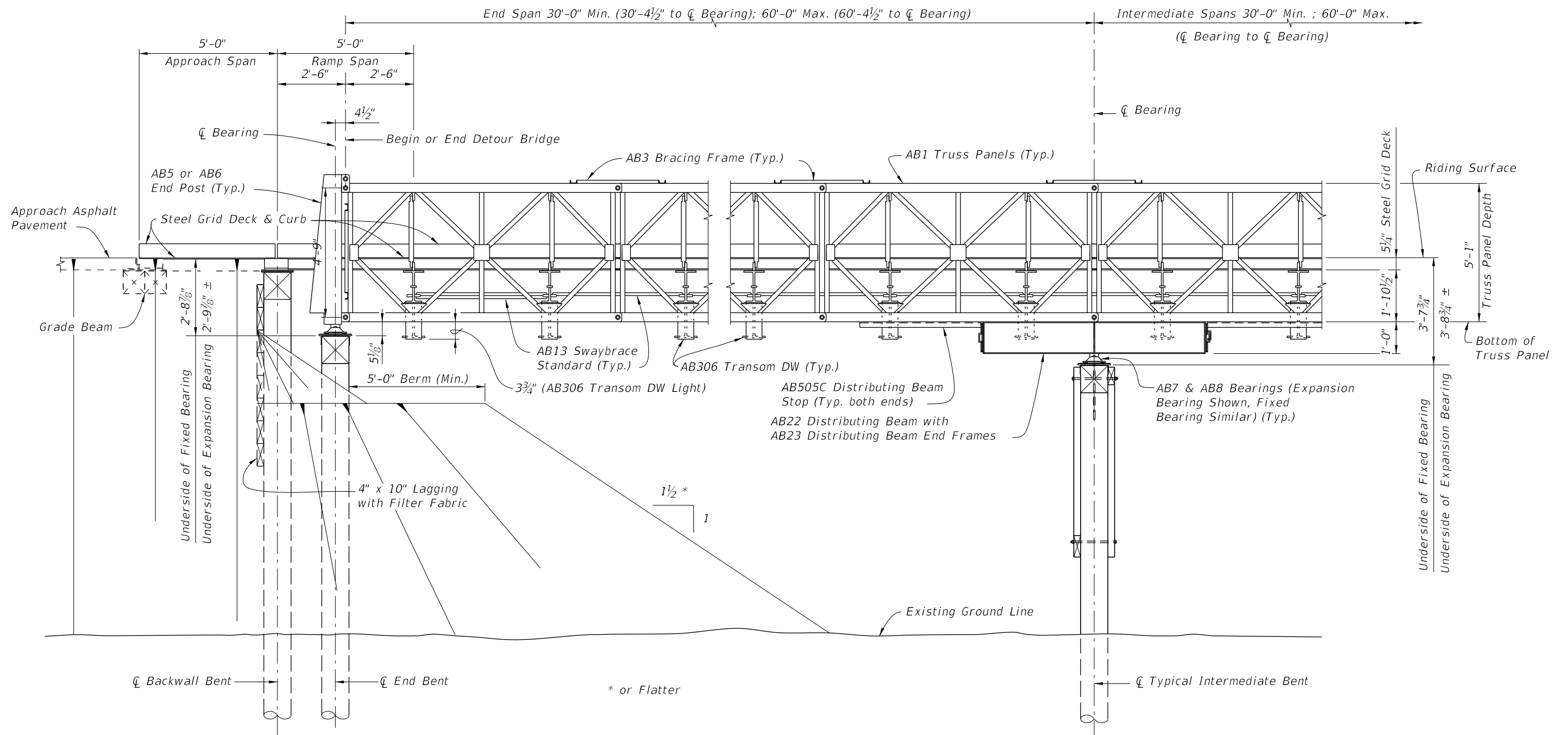

ELEVATION VIEW
 (TIMBER PILES SHOWN, STEEL H PILES AND STEEL PIPE PILES SIMILAR)
 (Thrie-Beam Panel not shown for clarity, See Index 102-240)

10/23/2018 10:55:00 AM

LAST REVISION 07/01/15	REVISION	DESCRIPTION:	 FY 2019-20 STANDARD PLANS	TEMPORARY DETOUR BRIDGE GENERAL NOTES AND DETAILS	INDEX 102-200	SHEET 3 of 7
---------------------------	----------	--------------	---	--	------------------	-----------------

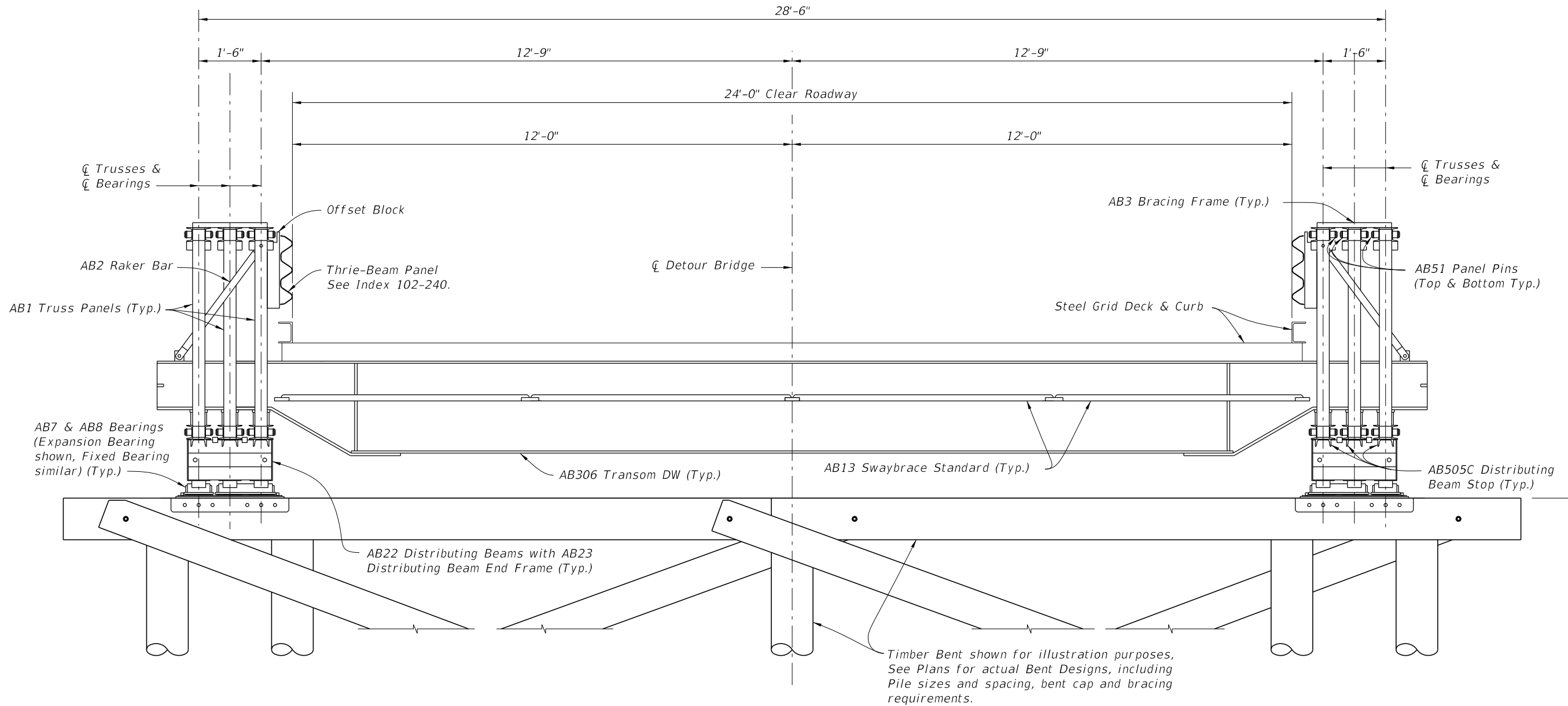

TYPICAL SECTION THRU DETOUR BRIDGE AT INTERIOR BENTS (TYPICAL SECTION AT END BENTS SIMILAR WITHOUT DISTRIBUTING BEAMS)
 (TIMBER PILES SHOWN, STEEL H PILES AND STEEL PIPE PILES SIMILAR)

Contractor supplied foundation components, including Bearing Saddle Plates, Keeper Bars & Shimms.
 FDOT supplied Temporary Bridge Components including Fixed & Expansion Bearings, Guardrail and associated components not included, see Payment Note, Sheet 1 of 7.

10/23/2018 10:55:01 AM

LAST REVISION 07/01/15	REVISION	DESCRIPTION:	 FY 2019-20 STANDARD PLANS	TEMPORARY DETOUR BRIDGE GENERAL NOTES AND DETAILS	INDEX 102-200	SHEET 4 of 7
---------------------------	----------	--------------	---	--	------------------	-----------------

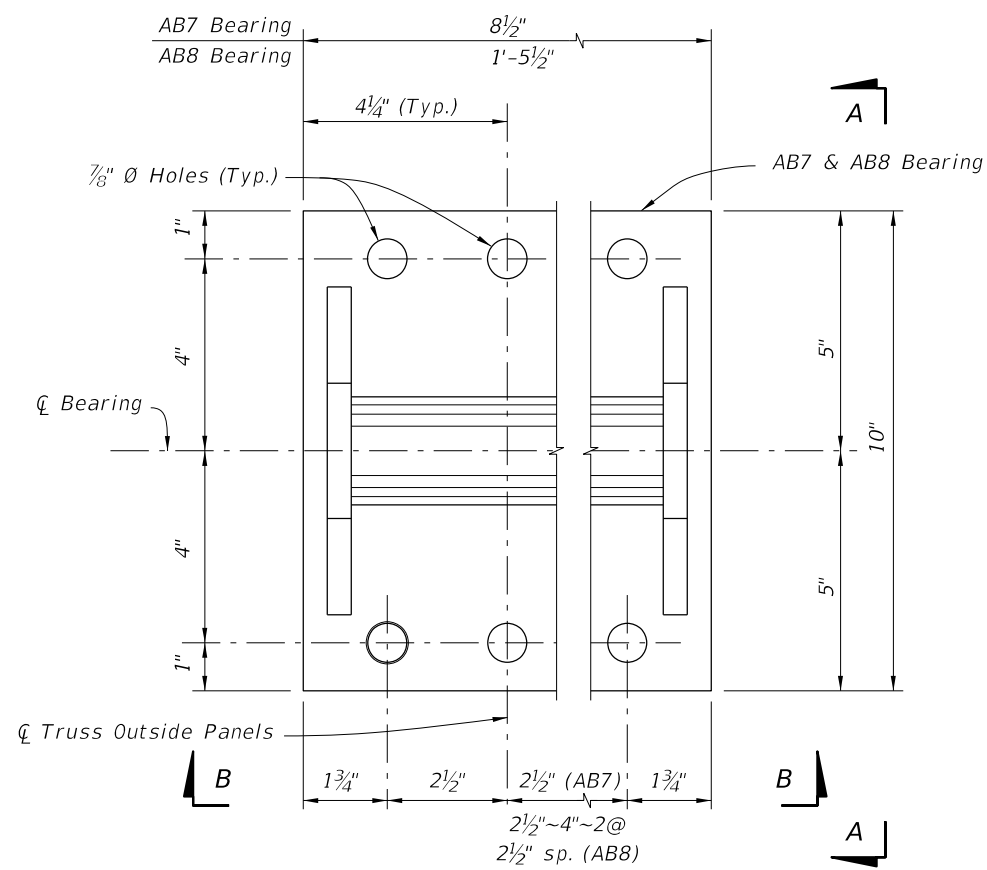

PLAN VIEW

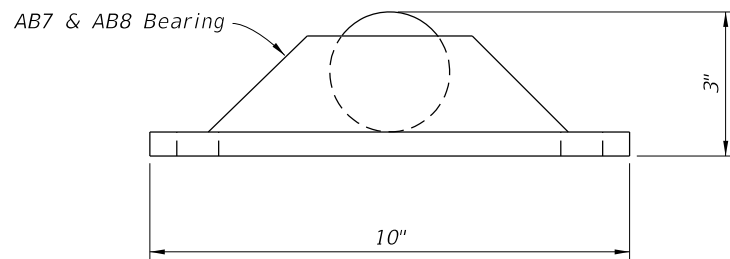
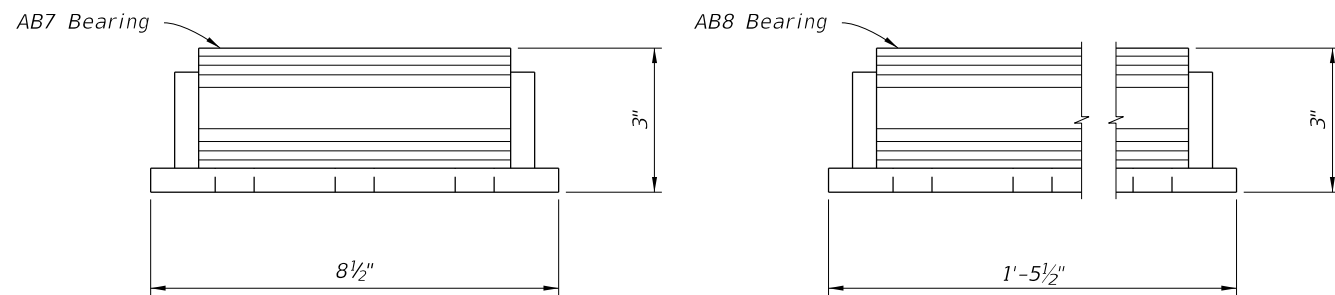

DETAILS FOR FDOT SUPPLIED FIXED BEARINGS

AB7 Bearing (2 Required for Double Truss)
Combined AB7 & AB8 Bearing (Triple Truss)

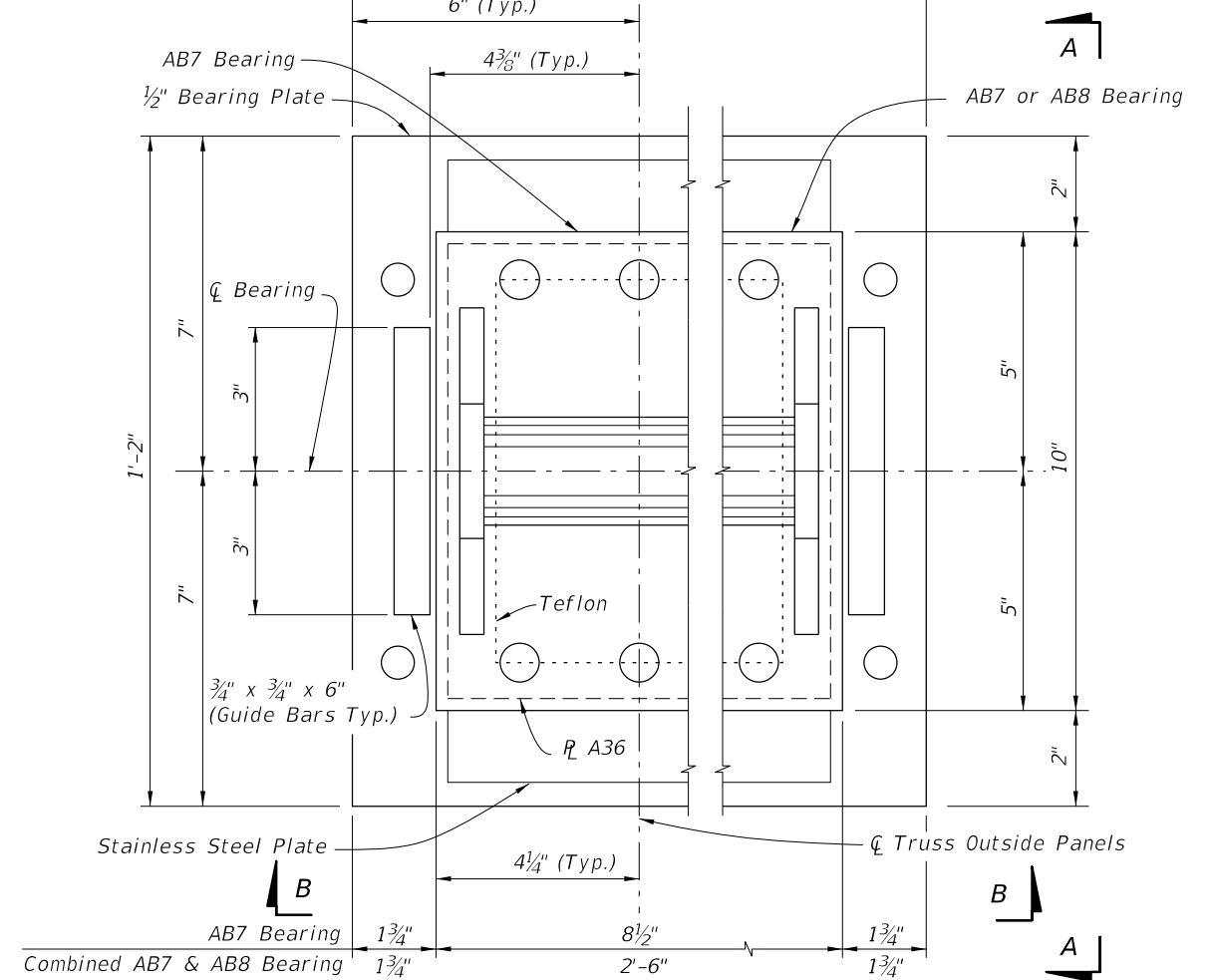

PLAN VIEW

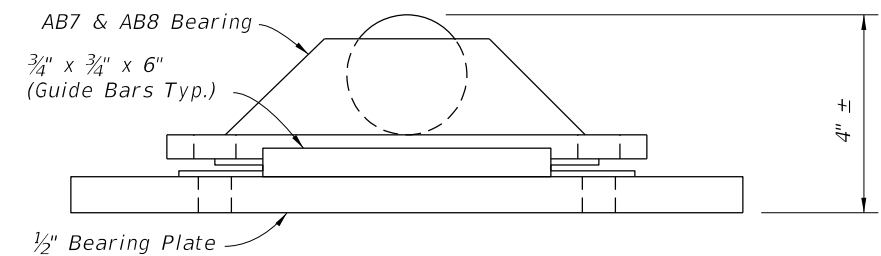
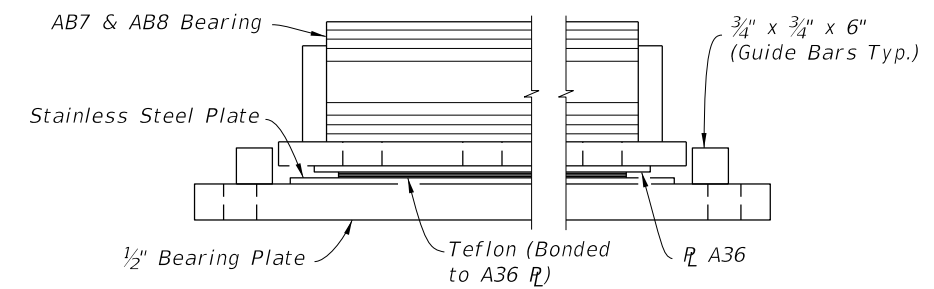

DETAILS FOR FDOT SUPPLIED EXPANSION BEARINGS

10/23/2018 10:55:01 AM

LAST REVISION	DESCRIPTION:
07/01/15	



FY 2019-20
STANDARD PLANS

TEMPORARY DETOUR BRIDGE
GENERAL NOTES AND DETAILS

INDEX
102-200

SHEET
5 of 7

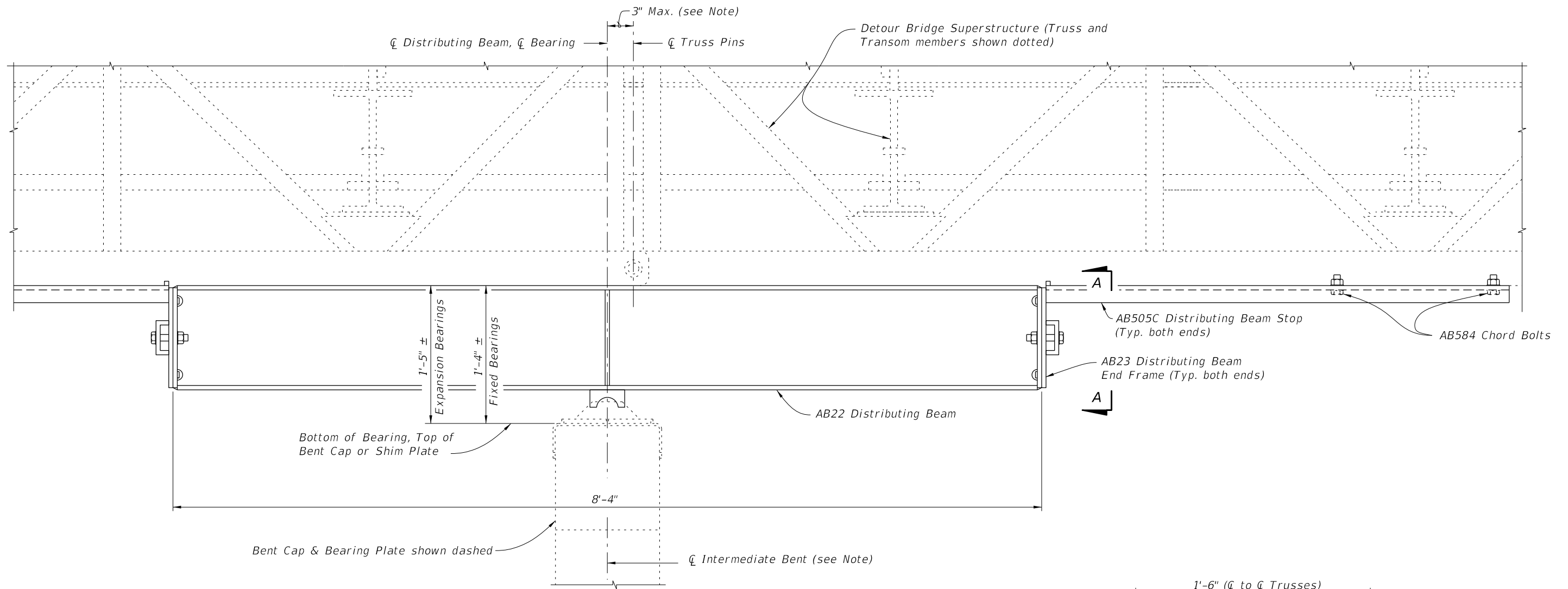

**ELEVATION VIEW OF DISTRIBUTING BEAM
(FIXED BEARING SHOWN, EXPANSION BEARING SIMILAR)
(Timber Intermediate Bent shown, Steel Intermediate Bents similar)**

Note:

Centerline of Bearing may be shifted from Centerline of Truss Pins as shown, Centerline of Intermediate Bent may be shifted from Centerline of Bearing an additional 3" to allow for pile placement tolerances.

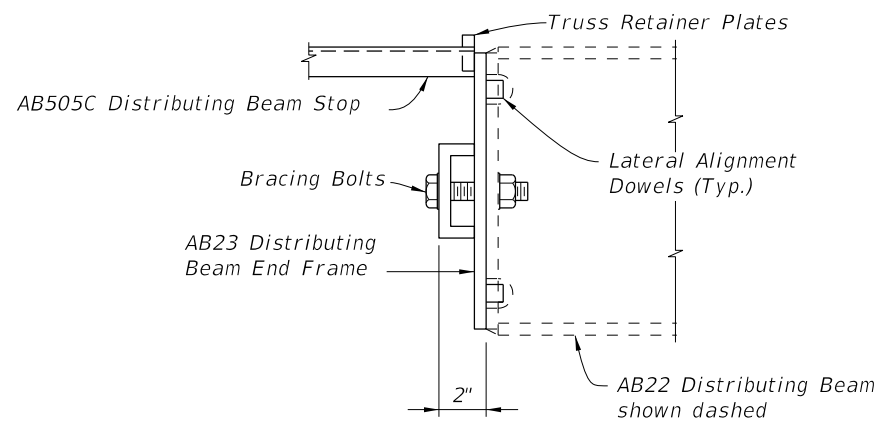

VIEW B-B

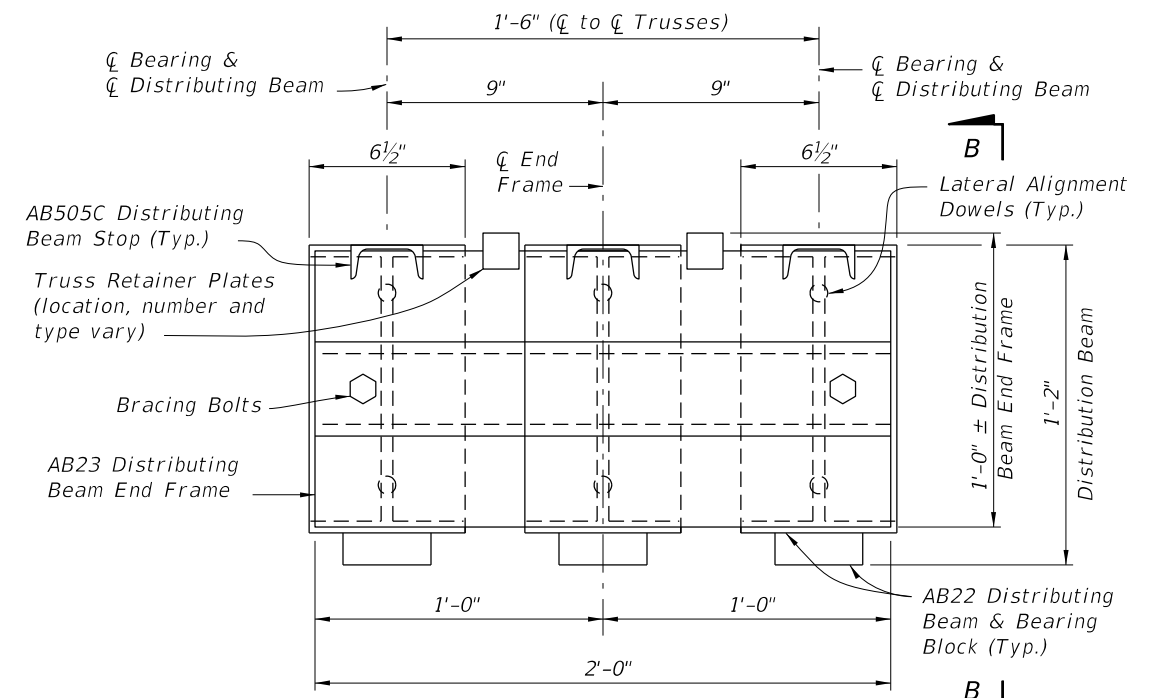

**END VIEW A-A
DISTRIBUTING BEAM END FRAME DETAIL**

10/23/2018 10:55:02 AM

LAST REVISION 07/01/15	REVISION	DESCRIPTION:
---------------------------	----------	--------------



FY 2019-20
STANDARD PLANS

TEMPORARY DETOUR BRIDGE
GENERAL NOTES AND DETAILS

INDEX
102-200

SHEET
6 of 7

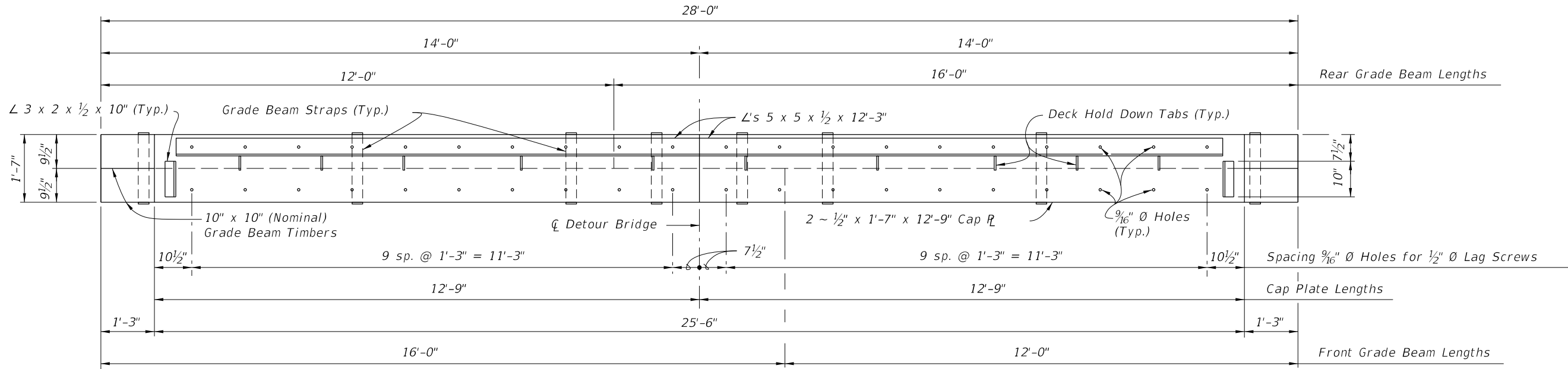

PLAN VIEW

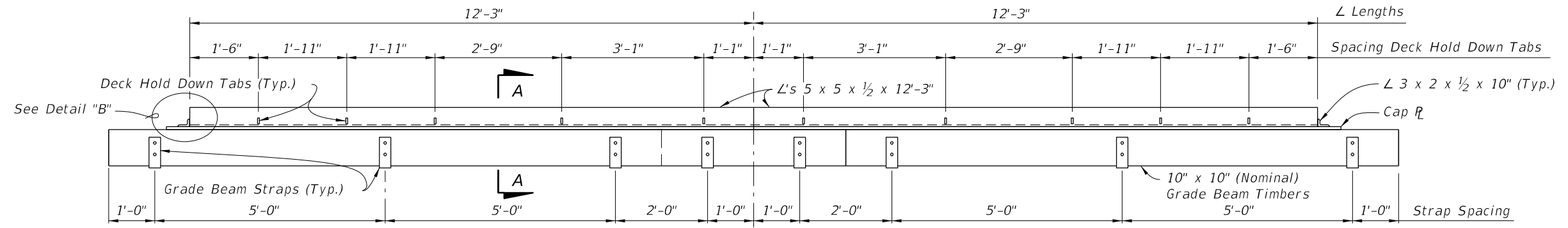

ELEVATION VIEW

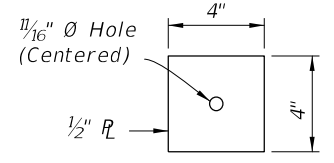

ANCHOR PLATE DETAIL

* See General Notes for setting widths other than 70° F.

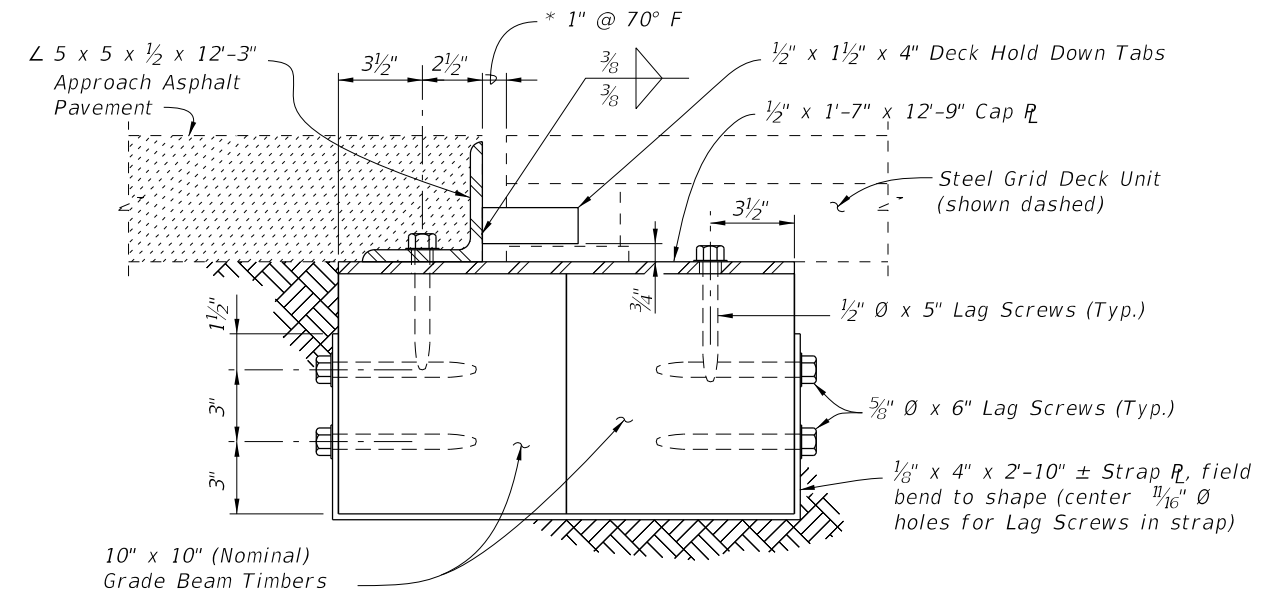

SECTION A-A

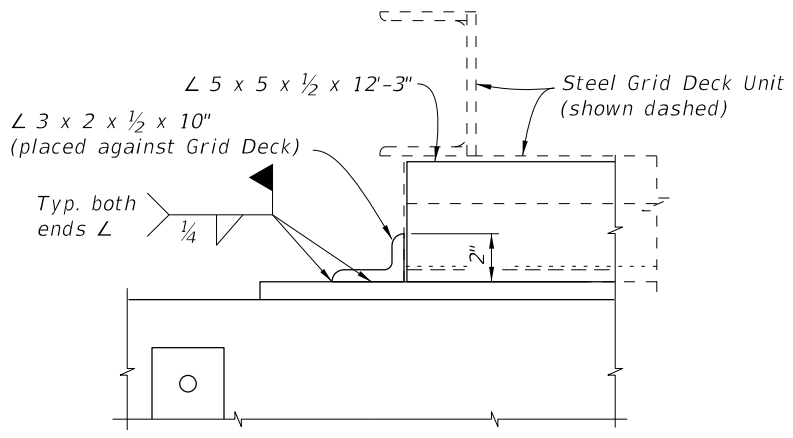

DETAIL "B"

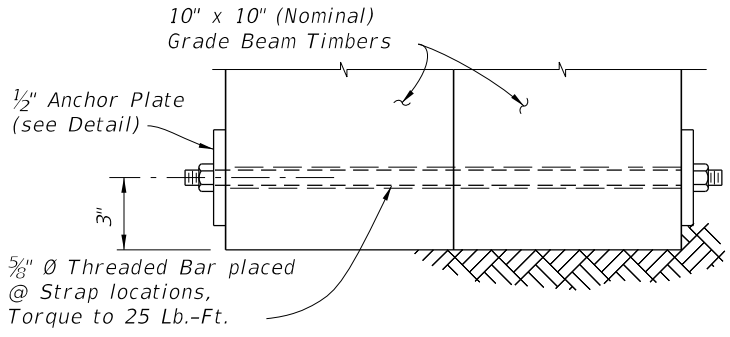

OPTIONAL THROUGH BOLT DETAIL (MAY BE USED IN LIEU OF STRAPS)

GRADE BEAM DETAILS

10/23/2018 10:55:03 AM

LAST REVISION 07/01/06	REVISION	DESCRIPTION:	 FY 2019-20 STANDARD PLANS	TEMPORARY DETOUR BRIDGE GENERAL NOTES AND DETAILS	INDEX 102-200	SHEET 7 of 7
---------------------------	----------	--------------	--	--	------------------	-----------------