

PLAN VIEW

CR-C

Shown

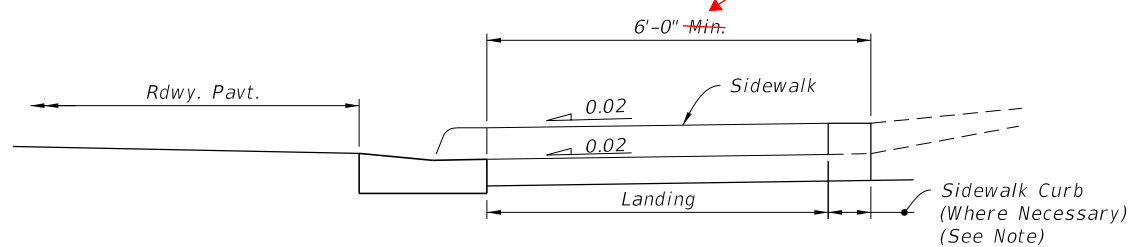

NOTE: For additional information on sidewalk curb construction, see SIDEWALK CURB OPTIONS details.

SECTION B-B

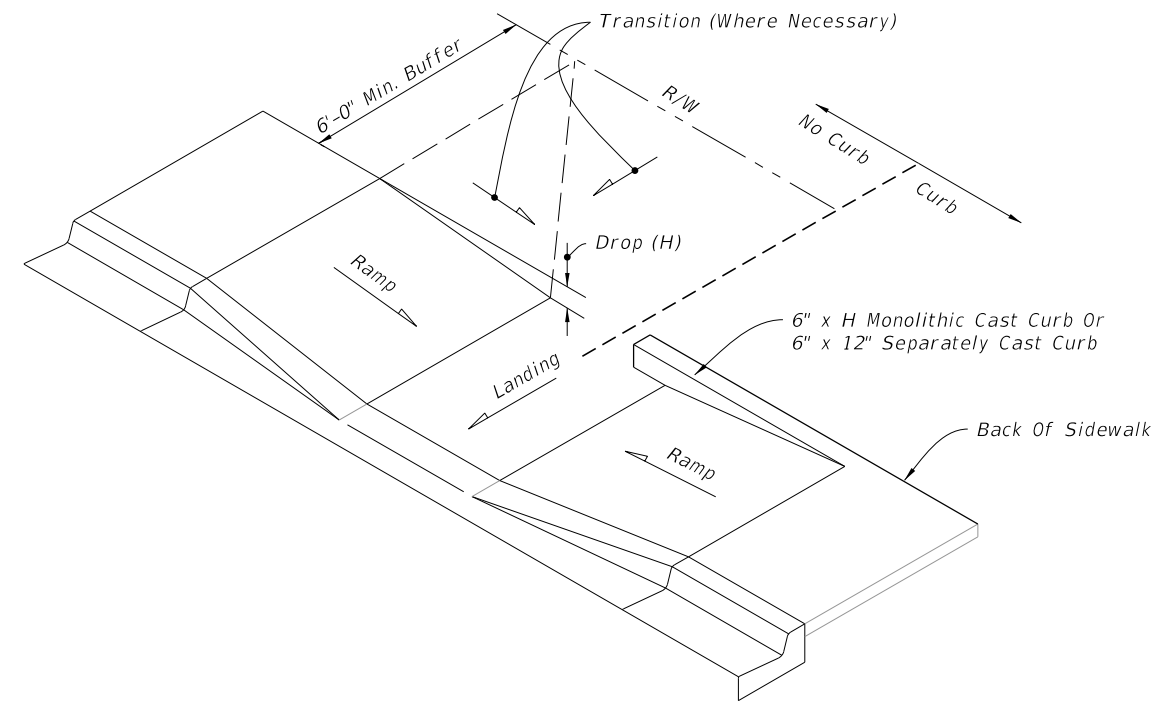

CONSTRUCTION OF SIDEWALK CURB IN CUT SECTIONS

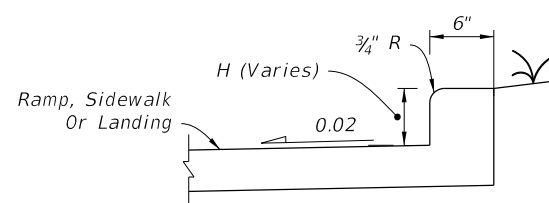

MONOLITHIC CAST CURB

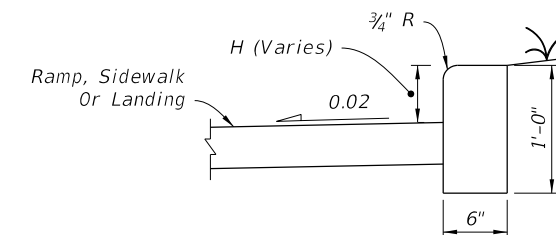

SEPARATELY CAST CURB

SIDEWALK CURB OPTIONS

SIDEWALK CURB RAMPS CR-C AND SIDEWALK CURB

12/4/2018 6:56:03 AM

LAST REVISION 11/01/18	DESCRIPTION:
---------------------------	--------------



FY 2019-20
STANDARD PLANS

DETECTABLE WARNINGS AND SIDEWALK CURB RAMPS

INDEX
522-002

SHEET
3 of 8

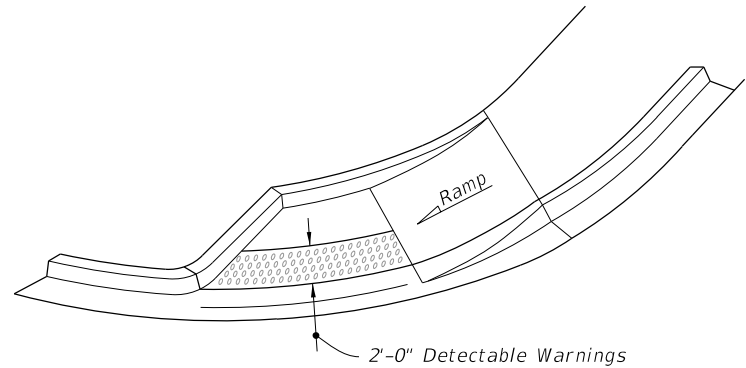

ISOMETRIC VIEW

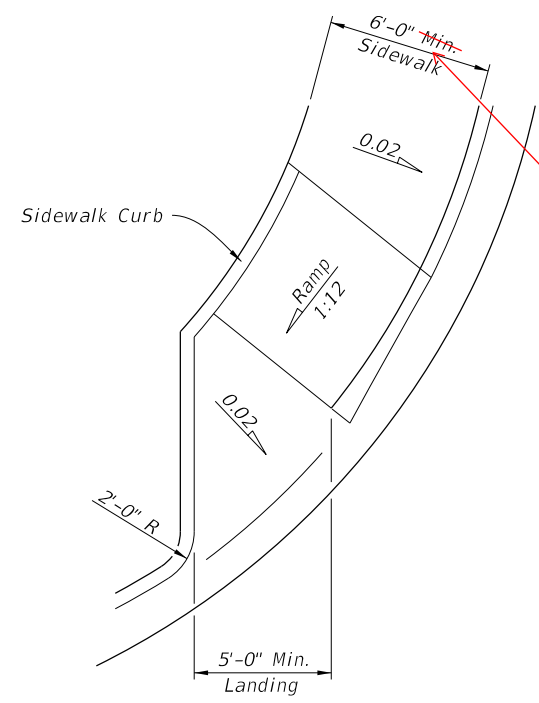

PLAN VIEW

CR-D

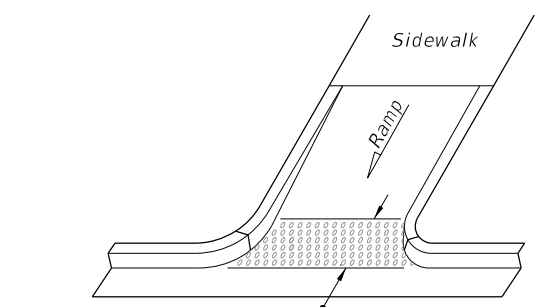

OPTION A

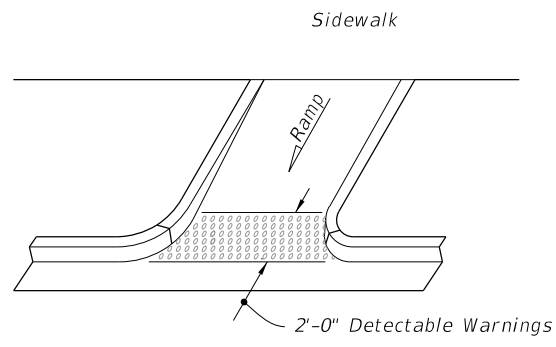

OPTION B
ISOMETRIC VIEW

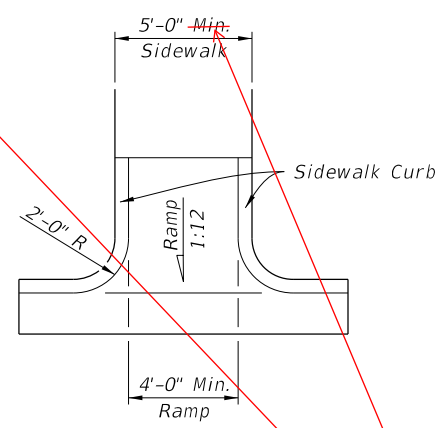

PLAN VIEW

CR-E

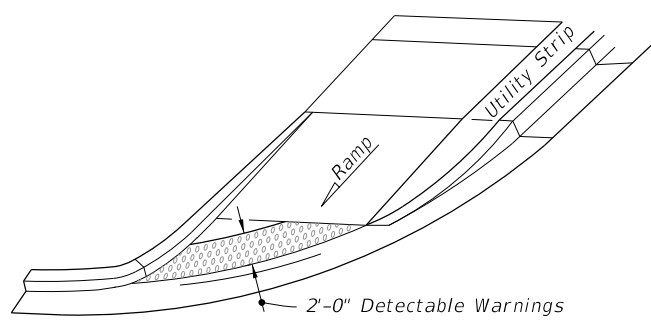

OPTION A

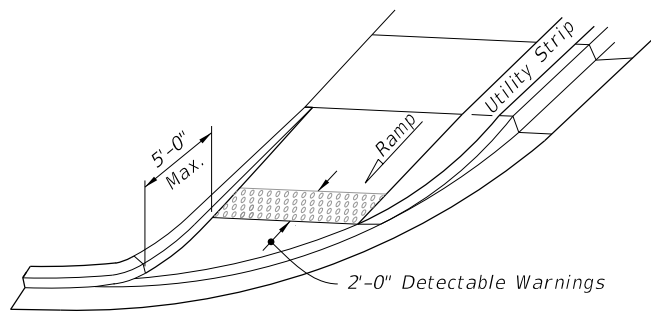

OPTION B
ISOMETRIC VIEW

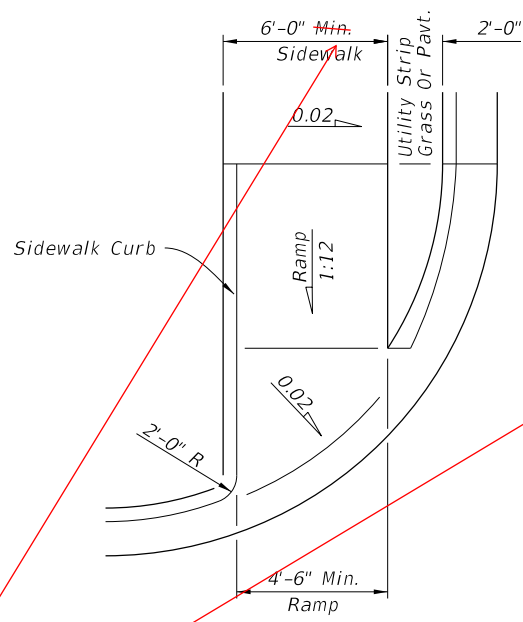

PLAN VIEW

CR-F

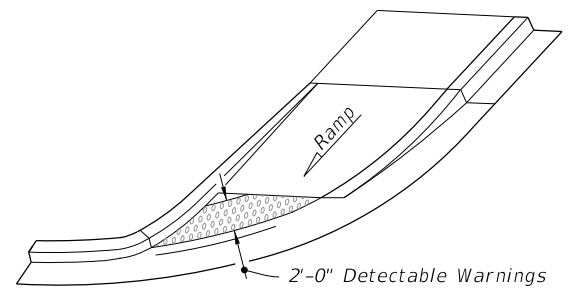

OPTION A

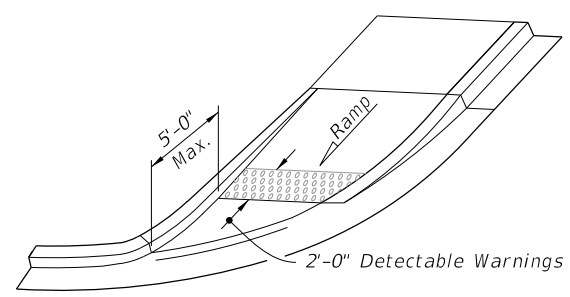

OPTION B
ISOMETRIC VIEW

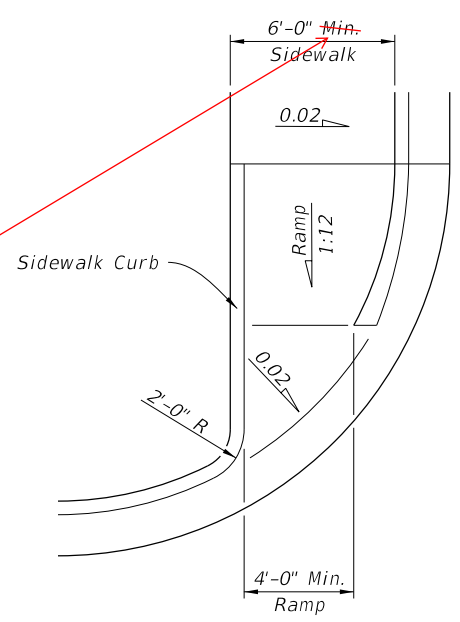

PLAN VIEW

CR-G

(Shown)

SIDEWALK CURB RAMPS CR-D, CR-E, CR-F & CR-G

12/4/2018 6:56:08 AM

LAST REVISION 11/01/18	DESCRIPTION:	 FY 2019-20 STANDARD PLANS	DETECTABLE WARNINGS AND SIDEWALK CURB RAMPS	INDEX 522-002	SHEET 4 of 8
---------------------------	--------------	----------------------------------	---	------------------	-----------------

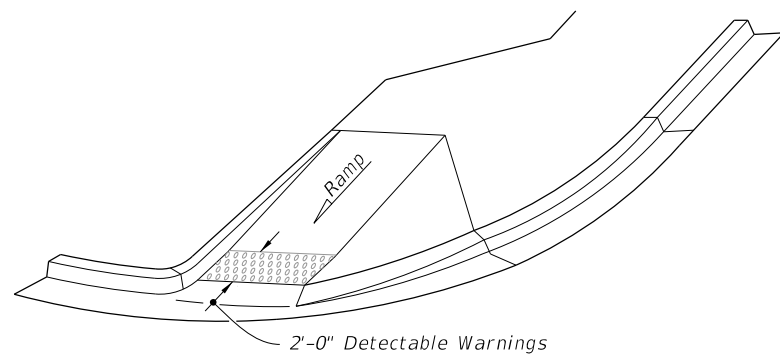

ISOMETRIC VIEW

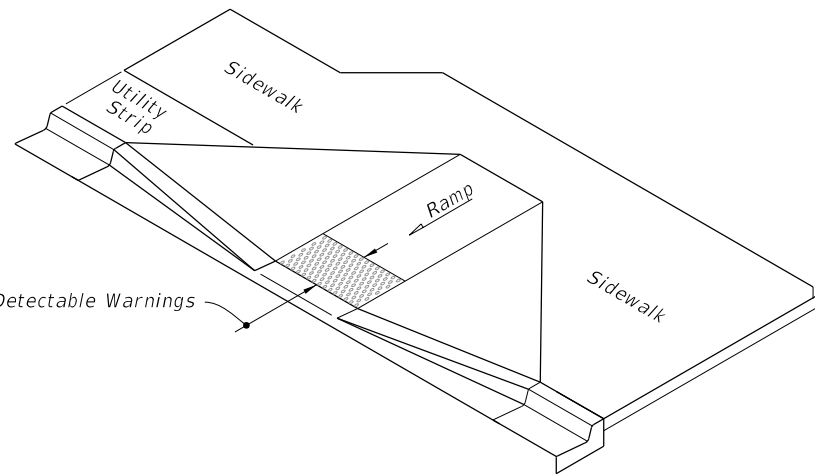

ISOMETRIC VIEW

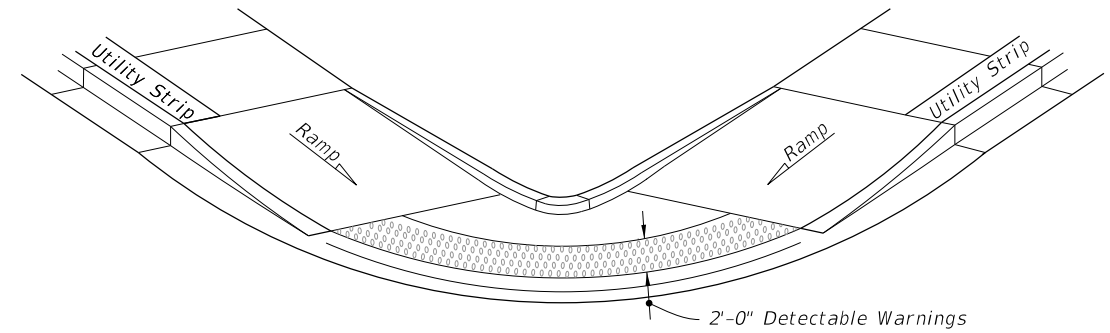

OPTION A

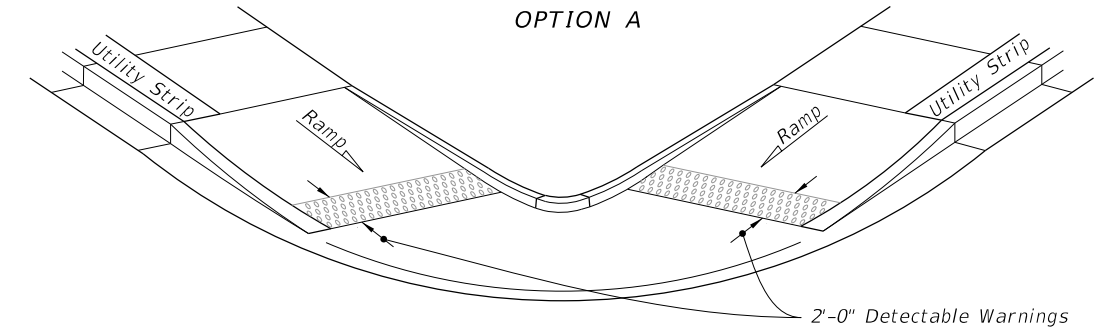

OPTION B

ISOMETRIC VIEW

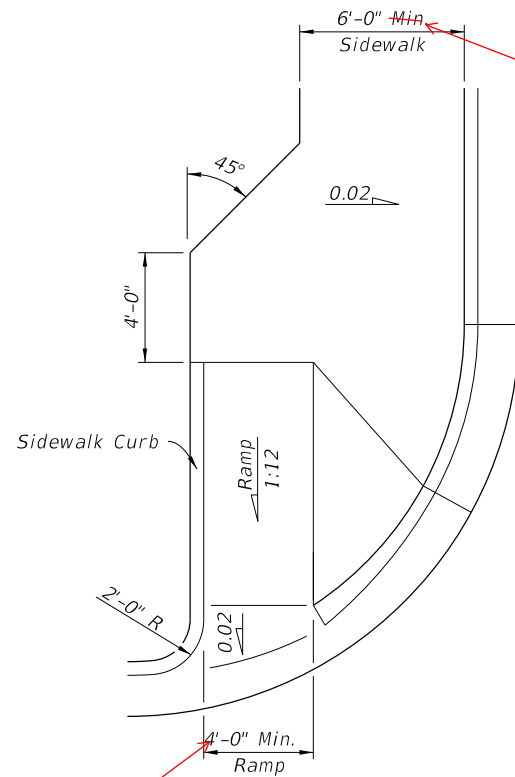

PLAN VIEW

CR-H

(Shown)

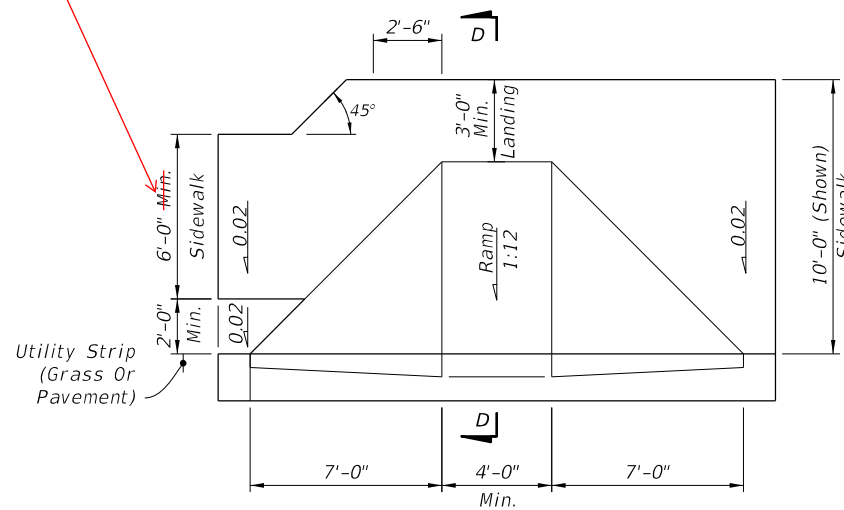

PLAN VIEW

CR-K

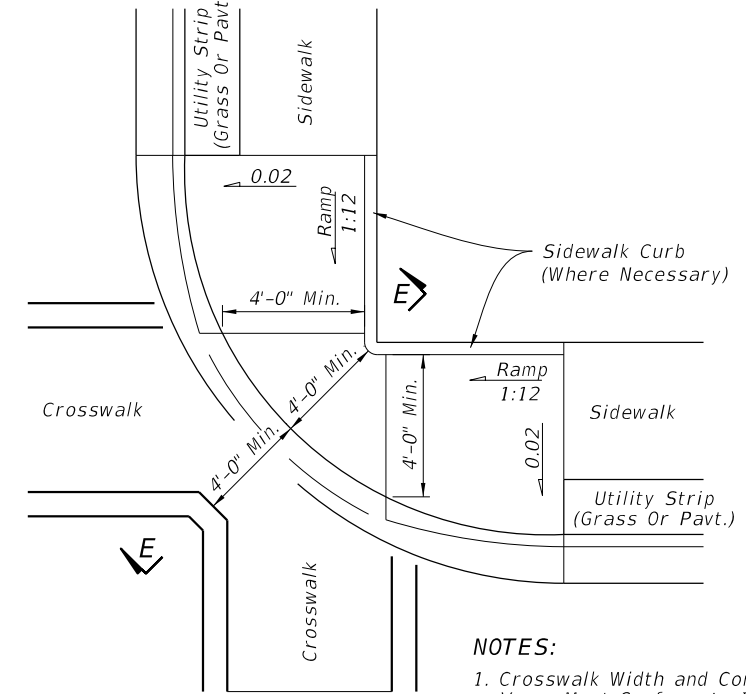

PLAN VIEW

CR-L

Align Dimension

8" For Type F Curb
9" For Type E Curb
(Type F Curb Shown)

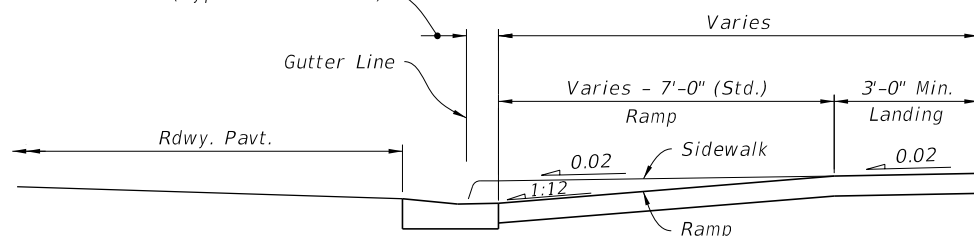

SECTION D-D

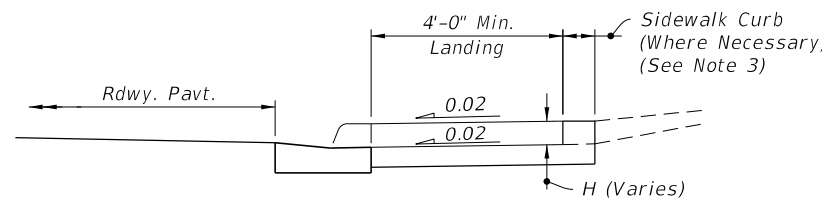

SECTION E-E

NOTES:

1. Crosswalk Width and Configuration Vary; Must Conform to Index 711-001.
2. 15' Radius Curve Shown for CR-L.
3. For additional information on sidewalk curb construction, see SIDEWALK CURB OPTIONS details, on Sheet 3.

SIDEWALK CURB RAMPS CR-H, CR-K & CR-L

12/4/2018 6:56:13 AM

LAST REVISION	DESCRIPTION:
11/01/18	



FY 2019-20
STANDARD PLANS

DETECTABLE WARNINGS AND SIDEWALK CURB RAMPS

INDEX
522-002

SHEET
5 of 8

(Shown)

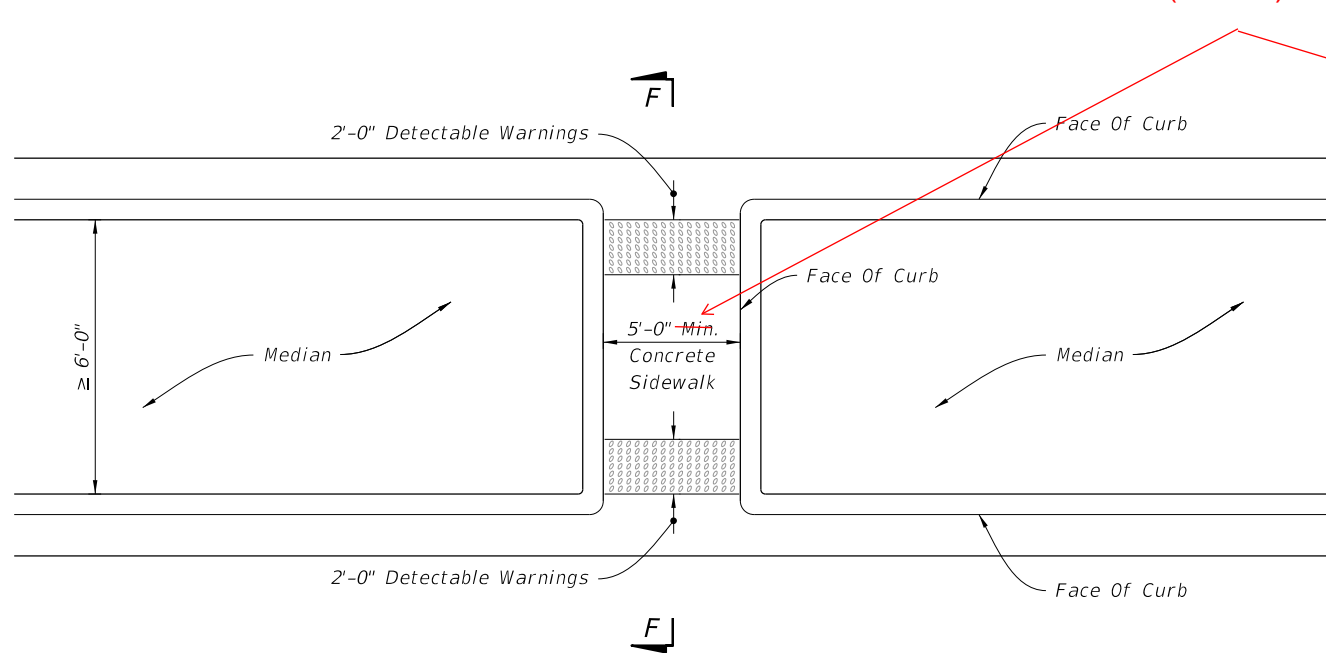

DEPRESSED SIDEWALK

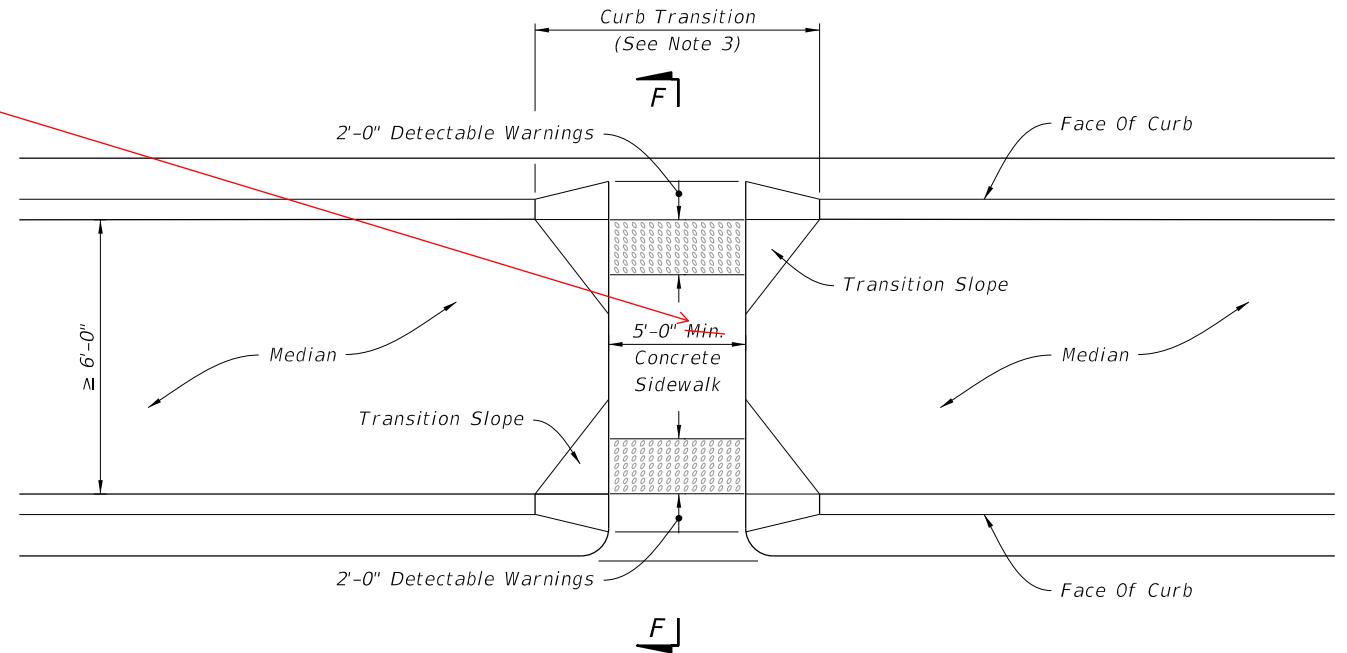

RAISED SIDEWALK

MEDIAN CROSSINGS

NOTES:

1. Cross Slope of the median crossing not to exceed 0.02.
2. Running Slopes:
 - A. Slopes ≤ 0.05 : For roadway cross sections where the Edge of Pavement elevation is the same for both directions of traffic, the median crossing running slopes (0.02 Typ.) should meet at the centerline of the median. For roadway cross sections with variable Edge of Pavement elevations, or to accommodate other construction in the median, the slopes may intersect off the centerline of the median.
 - B. Slopes > 0.05 : Provide a median refuge area (landing, 0.02 slope) for crossings with running slopes > 0.05 . The refuge area must extend the full width of the crossing and have a minimum length of 5 feet.
3. On existing facilities, remove and reconstruct curb transition for raised sidewalk with ramp.

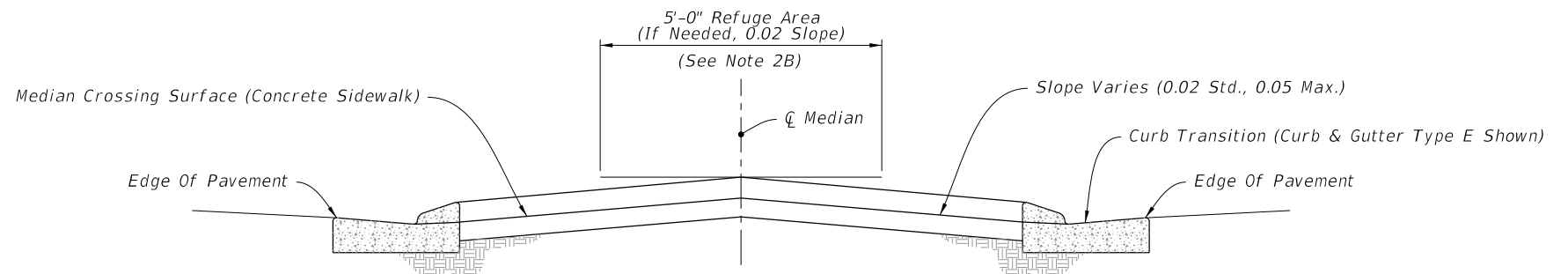

SECTION F-F

MEDIAN CROSSING

12/4/2018 6:56:25 AM

LAST REVISION 11/01/17	REVISION	DESCRIPTION:	 FY 2019-20 STANDARD PLANS	DETECTABLE WARNINGS AND SIDEWALK CURB RAMPS	INDEX 522-002	SHEET 7 of 8
---------------------------	----------	--------------	--	---	------------------	-----------------