

CONDUIT GENERAL NOTES:

1. Furnish and install approved Conduits, Fittings and Embedded Junction Boxes (EJB's) in accordance with Specification Sections 630 and 635, this Standard, the National Electric Code (NEC) and as directed by the Engineer.
2. Furnish and install Embedded Junction Boxes (EJB) with weatherproof covers sized in accordance with NEC requirements and the maximum size limits shown. Install EJB adjacent to the Begin and End of Bridges, Begin and End of Retaining Walls, (except omit EJB adjacent to the Bridge unless a precast Traffic Railing with junction slab is used), and at other locations as necessary to maintain 300 foot maximum spacing. See Plans for additional locations and details.
3. For Conduit not designated for future use, see Plans for details. For Conduit designated for future use, stub out and cap the Conduit. Drive a 3'-0"± long ¾" (min.) diameter Steel Pipe flush with the ground line adjacent to the end of the Conduit as shown on Sheets 2, 3 or 4. Provide the location of the stub out with Steel Pipe to the Engineer for inclusion on the As-Built Plans.
4. Shift vertical Railing reinforcement symmetrically to provide 2" clearance to EJB. Space shifted vertical reinforcement at minimum 3" centers. Cut horizontal Railing reinforcement to provide 2" clearance to EJB and provide supplemental reinforcement as shown. To facilitate placement of Conduit, Expansion Fittings, and Expansion/Deflection Fittings, shift reinforcing a maximum of 1" but do not cut railing reinforcing to facilitate Conduit or Fittings. Do not bundle Conduits, or Conduit and horizontal reinforcement.

* Reduce to 6" maximum when installed in Pedestrian/ Bicycle Railings.

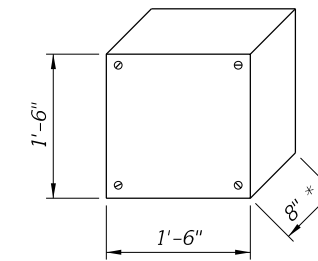

EJB "A"
Double Conduit
(Maximum Dimensions)

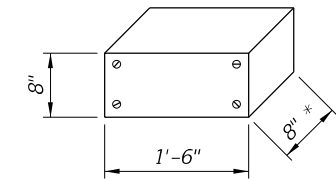

EJB "B"
Single Conduit
(Maximum Dimensions)

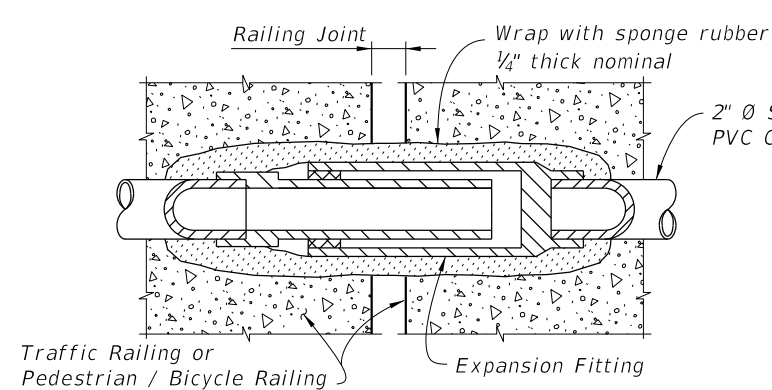

DETAIL "A"
EXPANSION FITTING DETAIL

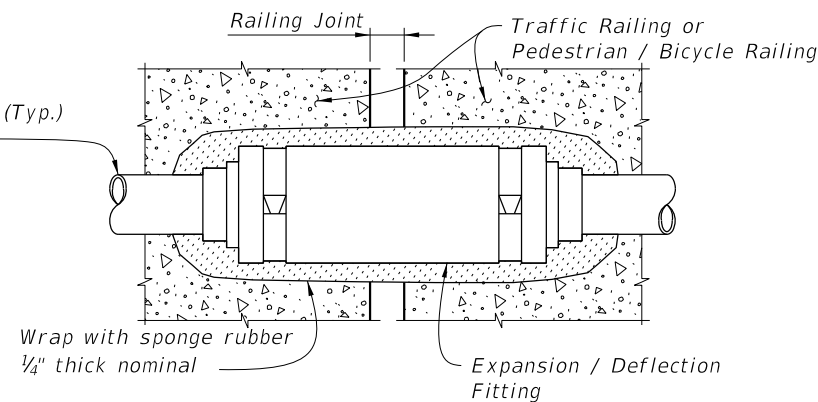

DETAIL "B" EXPANSION / DEFLECTION
FITTING DETAIL (CONCRETE / CONCRETE)

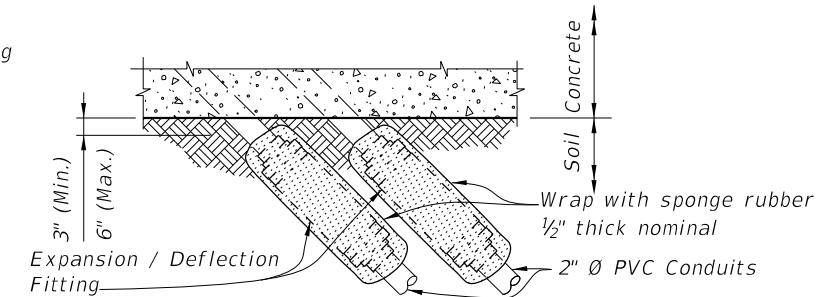

DETAIL "C" EXPANSION / DEFLECTION
FITTING DETAIL (CONCRETE / SOIL)

10/25/2017 3:43:06 PM

GENERAL

LAST REVISION 11/01/17	REVISION	DESCRIPTION:	 FY 2018-19 STANDARD PLANS	CONDUIT DETAILS - EMBEDDED	INDEX 630-010	SHEET 1 of 4
---------------------------	----------	--------------	---	----------------------------	------------------	-----------------

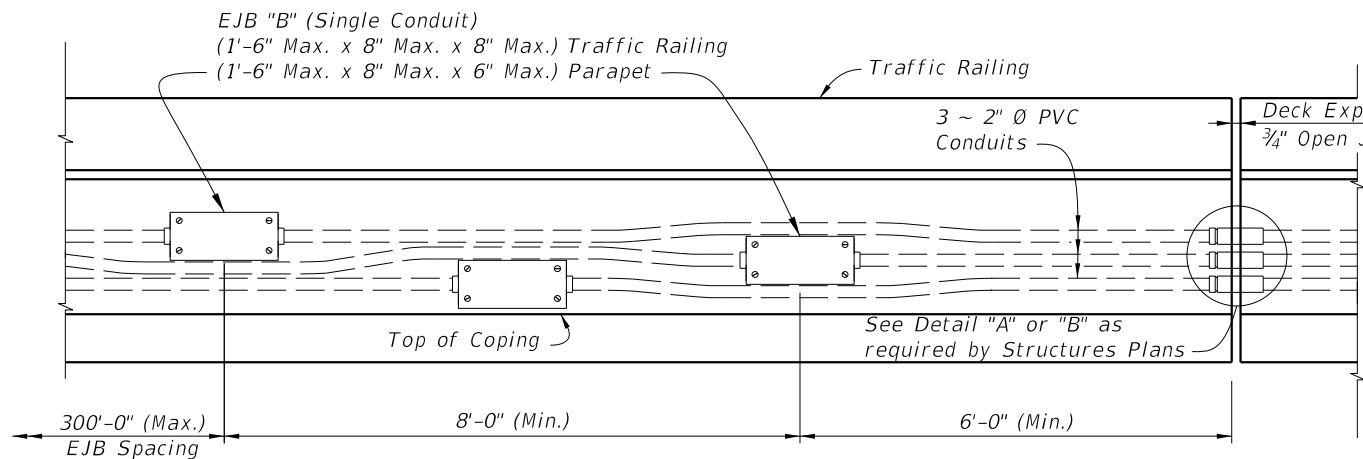

EJB "B" DETAIL

* 36" Single-Slope Traffic Railing shown, other Traffic Railings and Pedestrian/Bicycle Railings similar.
 ** EJB "A" shown, EJB "B" similar. See EJB "B" Detail.

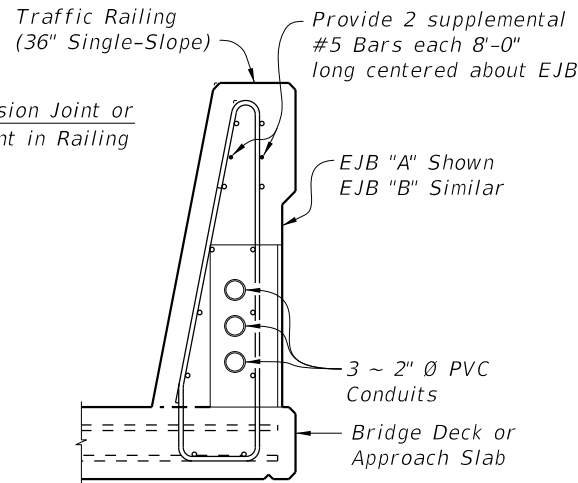

SECTION THRU TRAFFIC RAILING AT EJB (36" SINGLE-SLOPE SHOWN, 42" SINGLE-SLOPE SIMILAR)

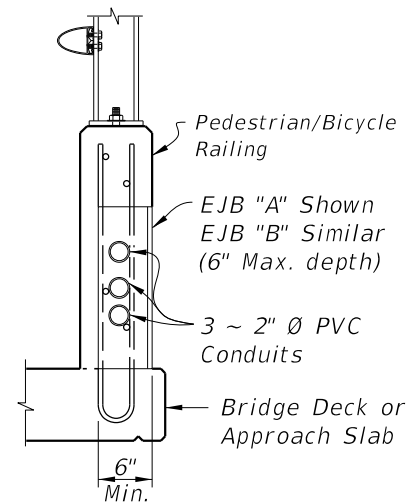

SECTION THRU PEDESTRIAN / BICYCLE RAILING AT EJB

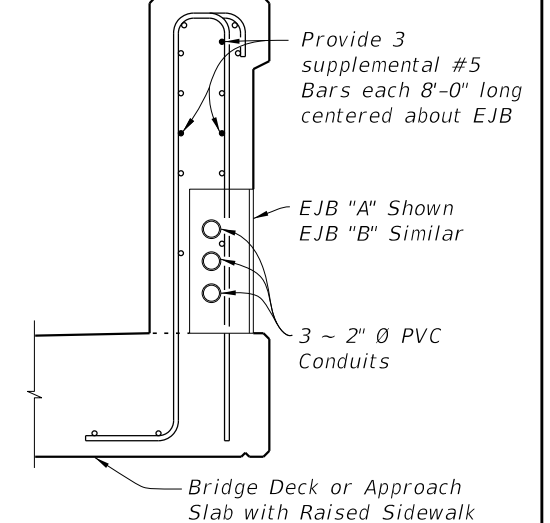

SECTION THRU TRAFFIC RAILING AT EJB (42" VERTICAL SHAPE SHOWN, 32" VERTICAL SHAPE SIMILAR)

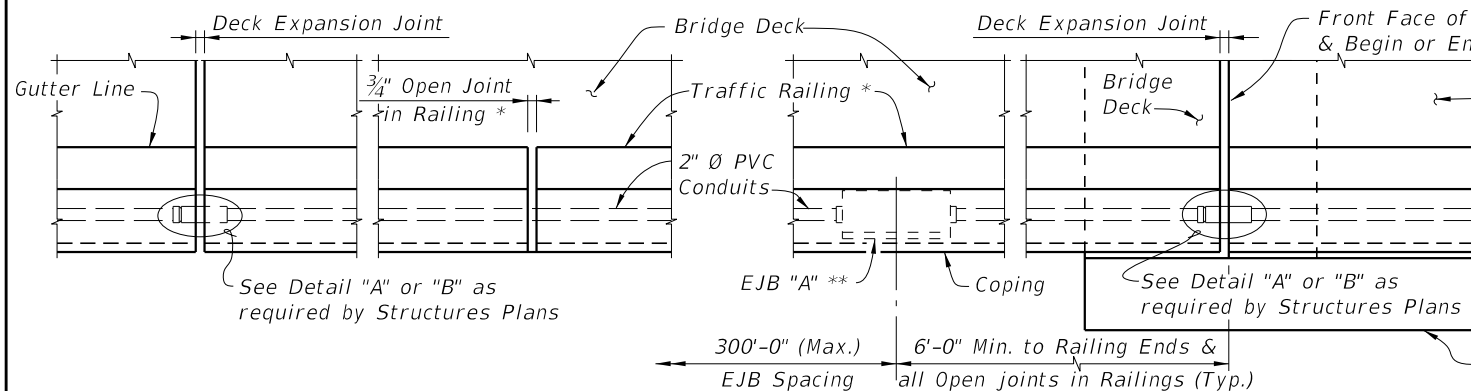

PARTIAL PLAN VIEW ALONG BRIDGE

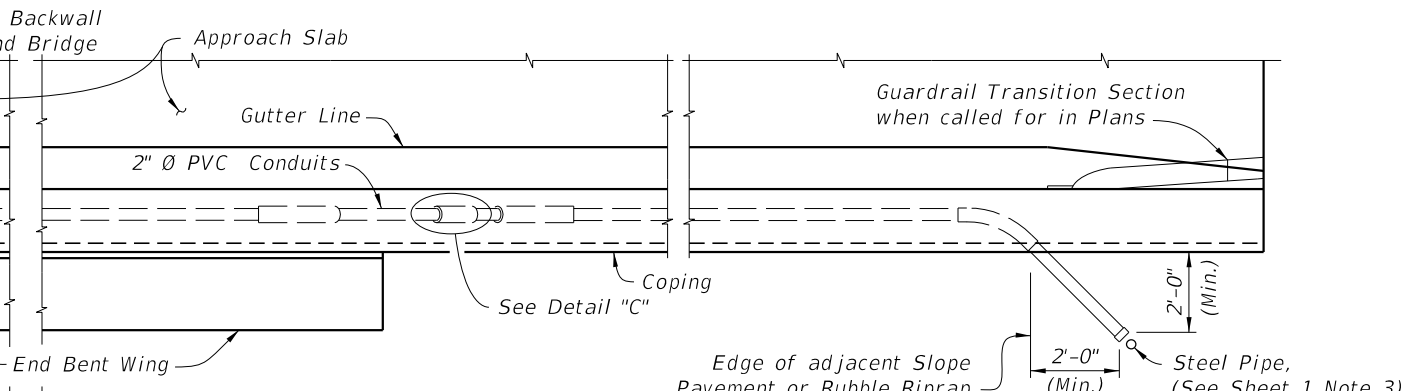

PARTIAL PLAN VIEW ALONG APPROACH SLAB WITHOUT CONTINUING TRAFFIC RAILING

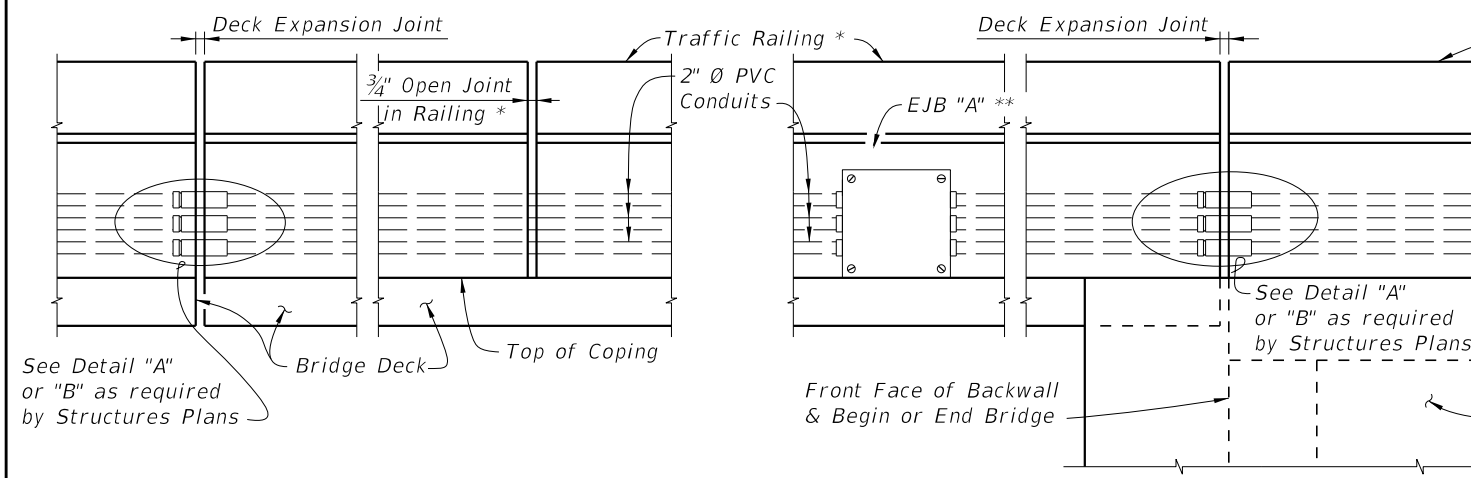

PARTIAL ELEVATION VIEW ALONG BRIDGE

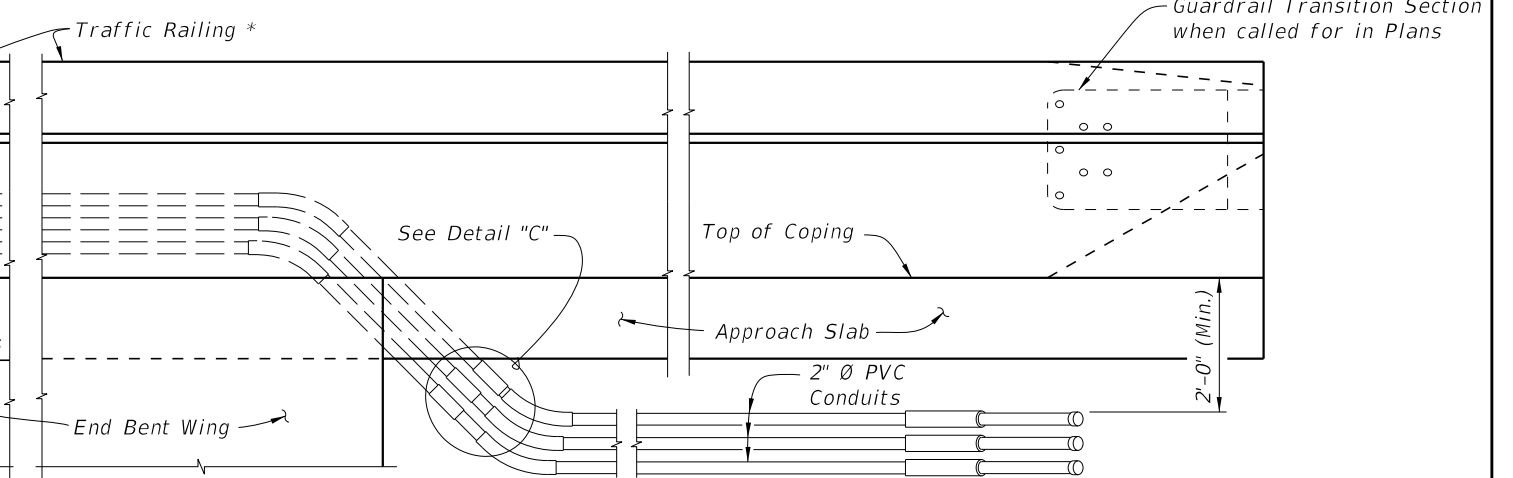

PARTIAL ELEVATION VIEW ALONG APPROACH SLAB WITHOUT CONTINUING TRAFFIC RAILING

Bridge and Approach Slab with Edge Railing

10/25/2017 3:43:07 PM

LAST REVISION 11/01/17	REVISION	DESCRIPTION:		FY 2018-19 STANDARD PLANS	CONDUIT DETAILS - EMBEDDED	INDEX 630-010	SHEET 2 of 4
---------------------------	----------	--------------	--	------------------------------	----------------------------	------------------	-----------------

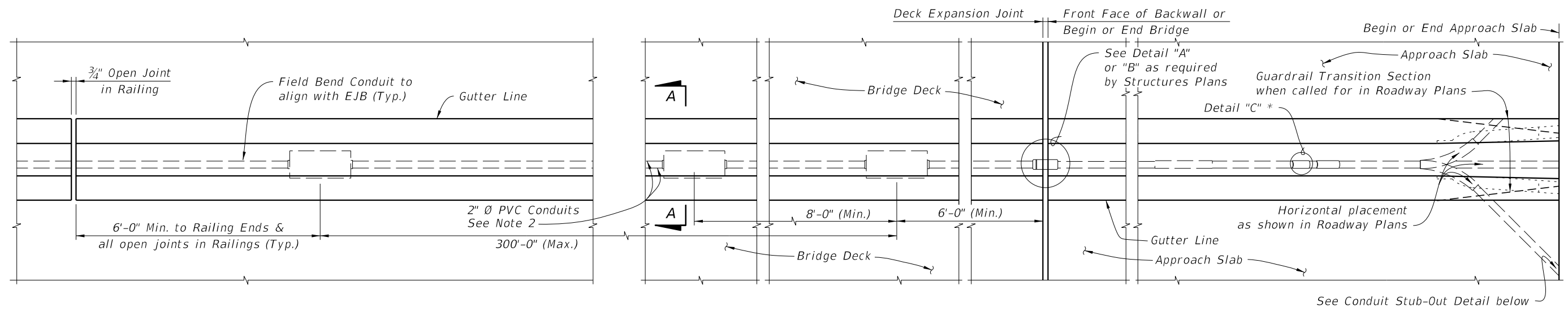

PARTIAL PLAN VIEW OF MEDIAN TRAFFIC RAILING ALONG BRIDGE

PARTIAL PLAN VIEW OF MEDIAN TRAFFIC RAILING ALONG APPROACH SLAB

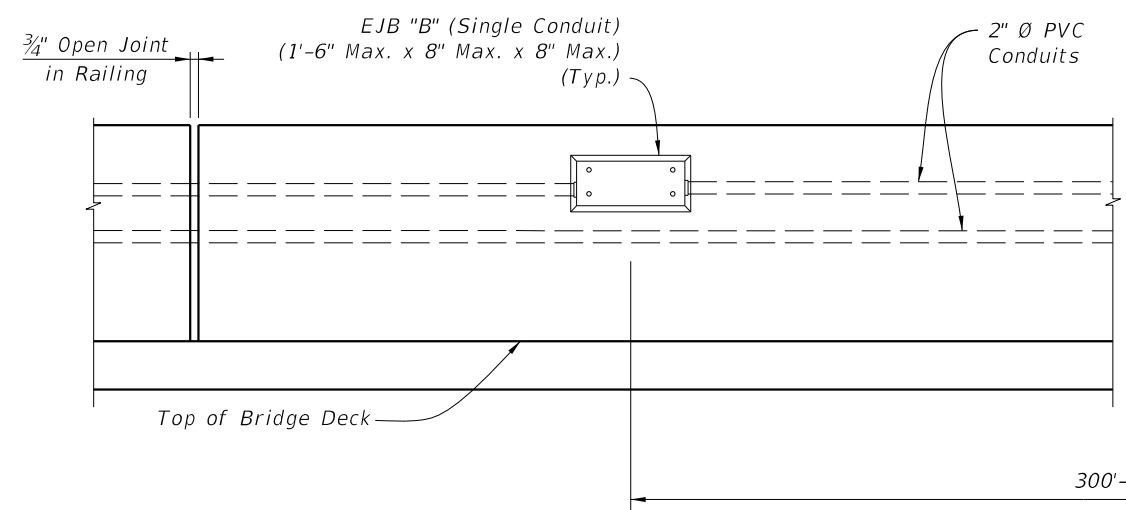

PARTIAL ELEVATION VIEW OF MEDIAN TRAFFIC RAILING ALONG BRIDGE

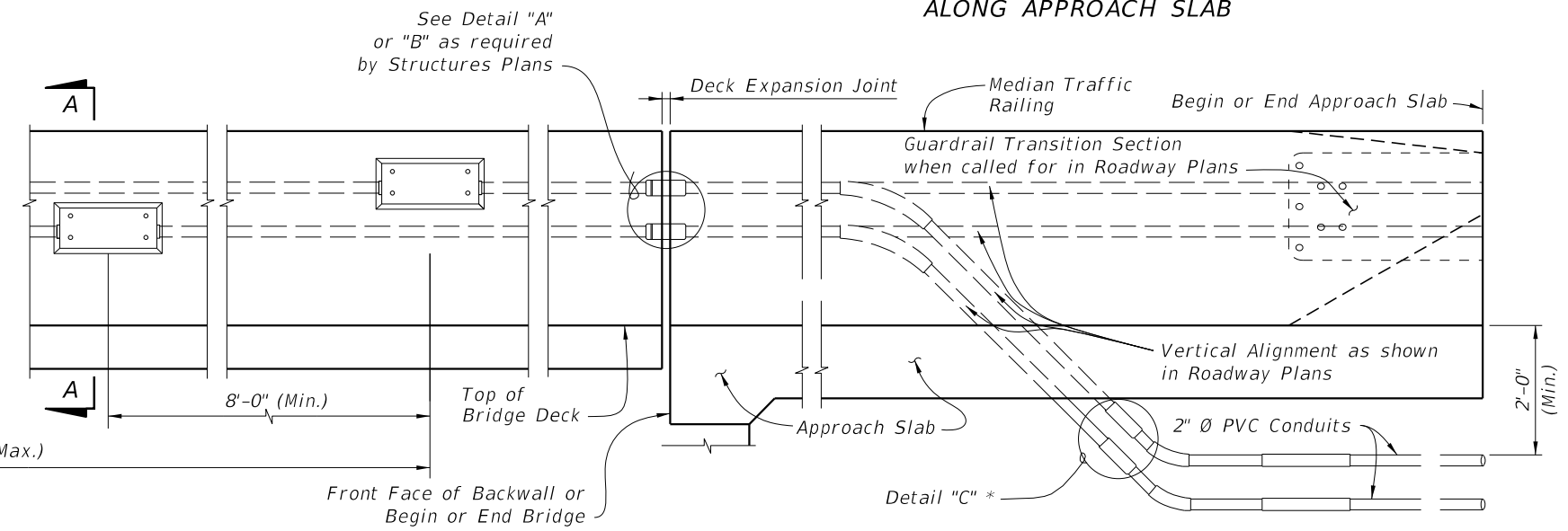

PARTIAL ELEVATION VIEW OF MEDIAN TRAFFIC RAILING ALONG APPROACH SLAB

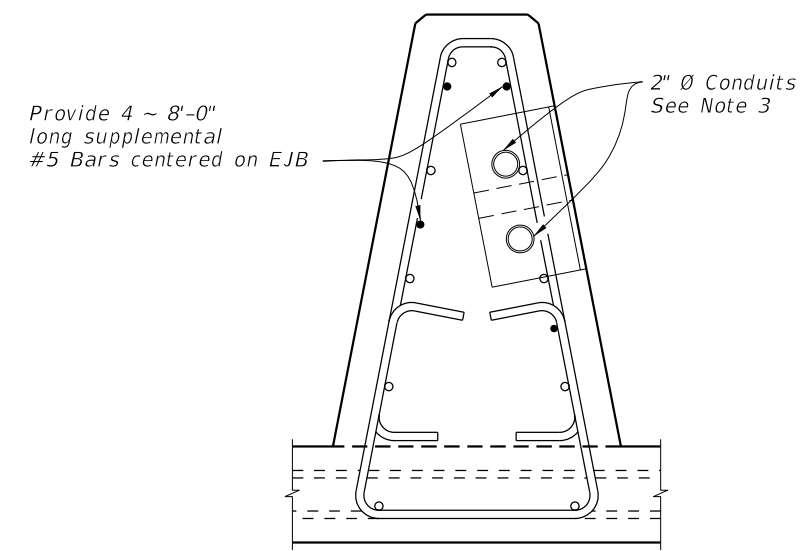

SECTION A-A
Median Traffic Railing (See Note 4)

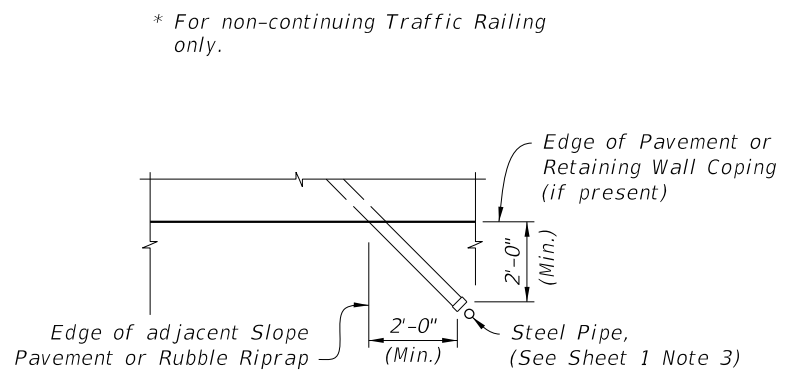

CONDUIT STUB-OUT DETAIL

- NOTES:
1. Work this sheet with Index 521-426.
 2. Adjust Conduit horizontally and vertically as necessary to align with EJB "B".
 3. When installed in traffic face of a railing, use EJB "B" with a minimum 3/8" thick galvanized steel cover.
 4. Position EJB such that, with gasket and cover plate secured and in place, cover plate is flush with the railing face. Flush is +1/8" to -1/4" measured with a horizontal straightedge.

10/25/2017 3:43:07 PM

Bridge and Approach Slab with Median Traffic Railing

LAST REVISION 11/01/17	DESCRIPTION:	 FY 2018-19 STANDARD PLANS	CONDUIT DETAILS - EMBEDDED	INDEX 630-010	SHEET 3 of 4
---------------------------	--------------	----------------------------------	----------------------------	------------------	-----------------

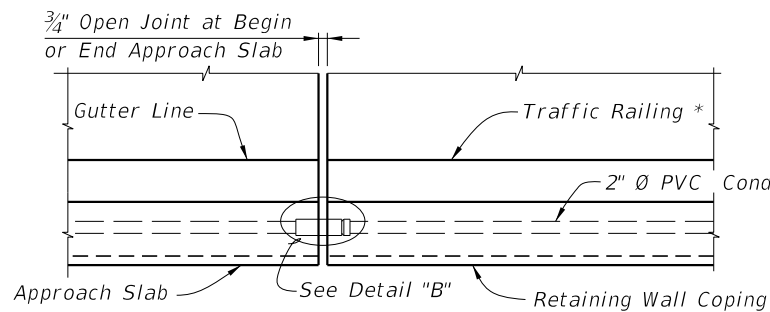

PARTIAL PLAN VIEW ALONG APPROACH SLAB WITH CONTINUING TRAFFIC RAILING

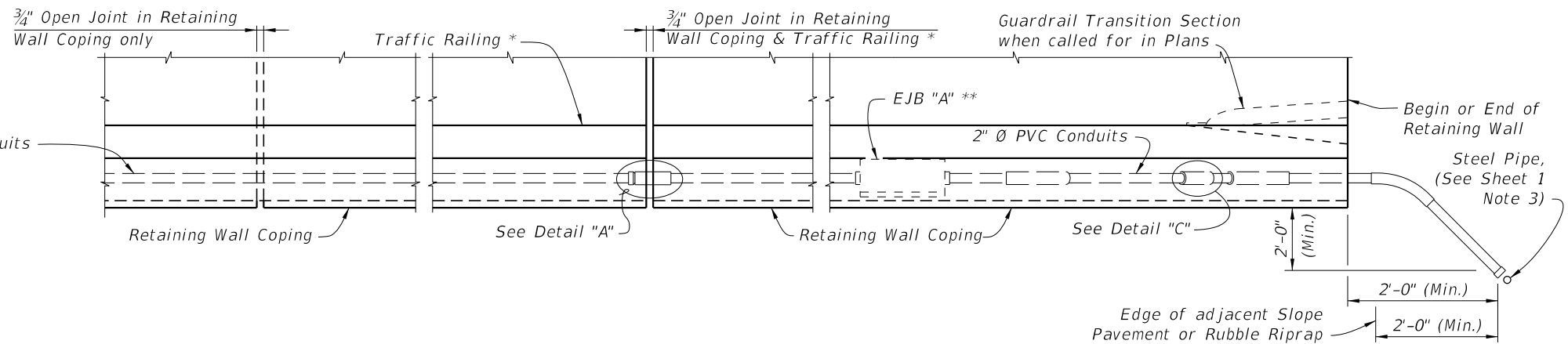

PARTIAL PLAN VIEW ALONG RETAINING WALL

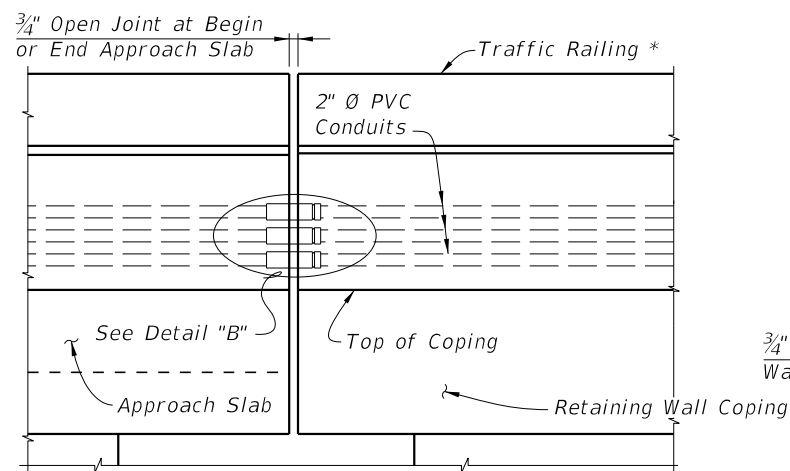

PARTIAL ELEVATION VIEW ALONG APPROACH SLAB WITH CONTINUING TRAFFIC RAILING (Retaining Wall Mounted Traffic Railing shown, Roadway Concrete Barrier similar)

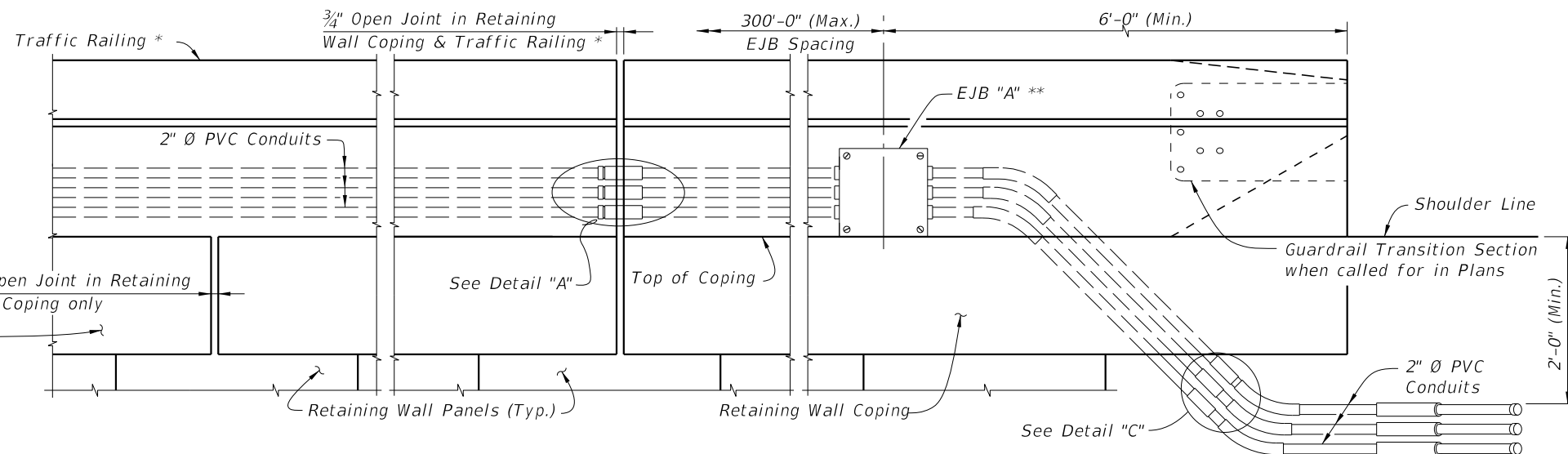

PARTIAL ELEVATION VIEW ALONG RETAINING WALL

* 36" Single-Shape Traffic Railing shown, other Traffic Railings and Pedestrian / Bicycle Railing similar. (See Sheet 2)
 ** EJB "A" shown EJB "B" similar. See EJB "B" Detail on Sheet 2.

10/25/2017 3:43:08 PM

Approach Slab and Retaining Wall with Railing

LAST REVISION 11/01/17	REVISION	DESCRIPTION:	 FY 2018-19 STANDARD PLANS	CONDUIT DETAILS - EMBEDDED	INDEX 630-010	SHEET 4 of 4
---------------------------	----------	--------------	---	----------------------------	------------------	-----------------