

**SECTION MATTING FOR DITCH**

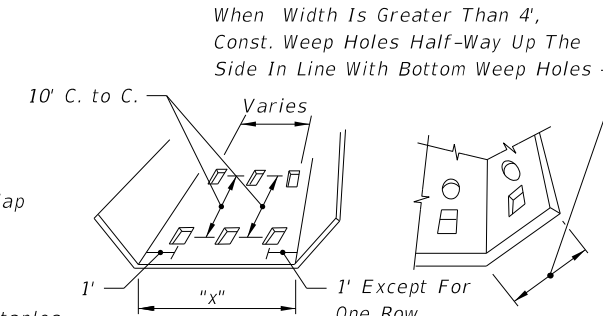

When "x" = 1' To 4' Const. 1 Row (Centered)  
 "x" = 5' To 7' Const. 2 Rows  
 "x" = 8' To 12' Const. 3 Rows  
 "x" = 13' To 17' Const. 4 Rows  
 "x" = 18' To 22' Const. 5 Rows

Note: All weep holes to be 3"x4" rectangle or 4" or 5" dia. circle hole. 1/2 cu. ft. (12" x 12" x 6") of No. 6 aggregate to be placed under each hole. 1 sq. ft. of galv. wire mesh (1/4" openings) shall be placed between the aggregate and the ditch pavement. Cost of holes, aggregate and wire mesh to be included in the cost of ditch pavement.

**WEEP HOLE ARRANGEMENT**

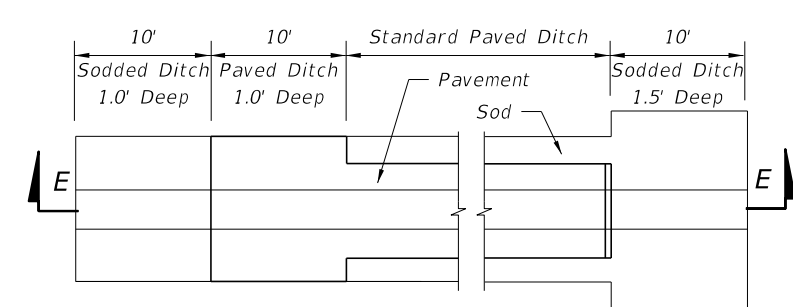
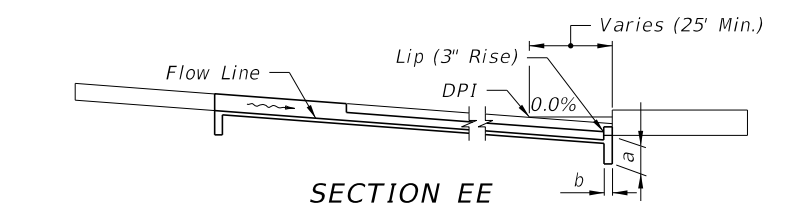

**PAVED DITCH END TREATMENT**

TO REPLACE:	W	d	R	Rows Of Weep Holes	Arc Length
6' Median Swale	6'	0.24'	19'	0	6.0'
<b>1:6 Front Slopes; 1:4 Back Slope</b>					
5' Ditch Bottom Width	10'	0.67'	19'	2	10.1'
4' Ditch Bottom Width	9'	0.54'	19'	2	9.1'
<b>1:4 Front Slopes &amp; Back Slope</b>					
5' Ditch Bottom Width	9'	0.74'	14'	2	9.2'
4' Ditch Bottom Width	8'	0.58'	14'	1 (in center)	8.1'

For use only where side slopes are 1:4 or flatter. Point "A" and "B" are to be the same elevation and should be used to locate the paved section.

**ALTERNATE DITCH PAVEMENT**

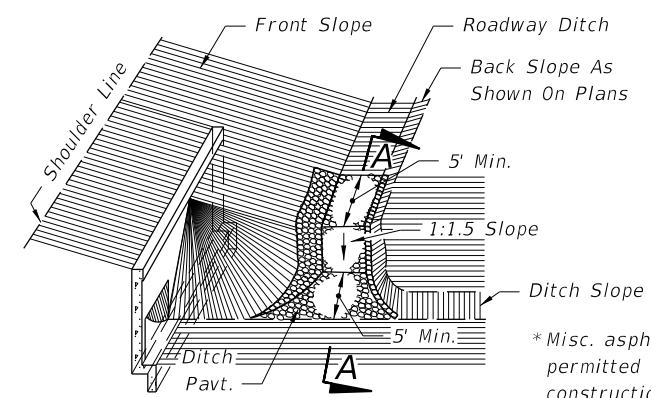

**JUNCTION OF ROADWAY DITCH\* AND LATERAL DITCH**

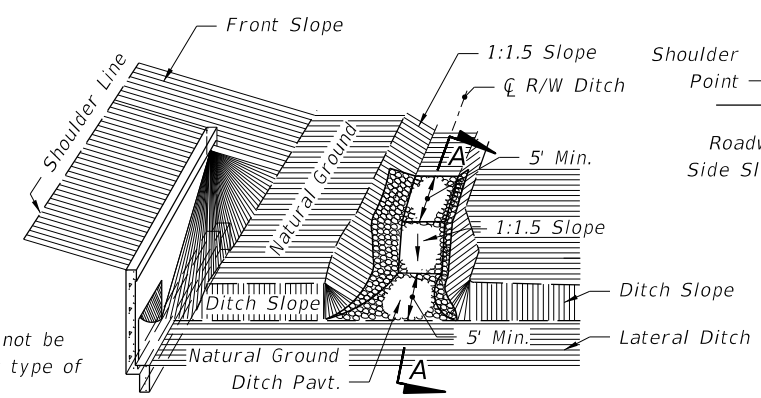

**JUNCTION OF R/W DITCH\* AND LATERAL DITCH**

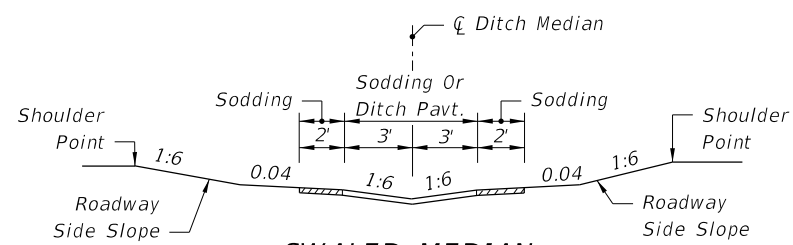

**SWALED MEDIAN (No Weep Holes)**

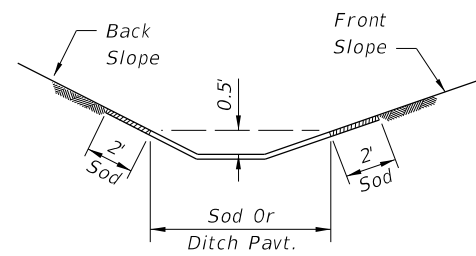

**ROADWAY SIDE DITCH**

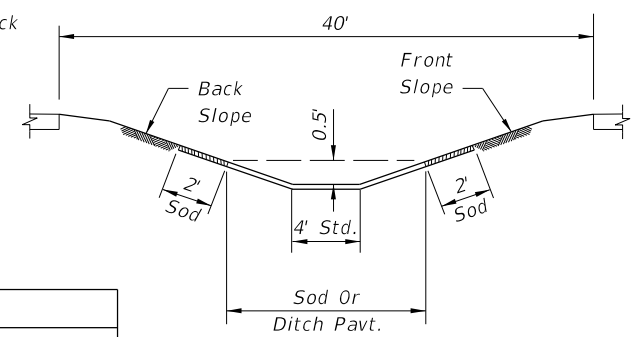

**40' MEDIAN**

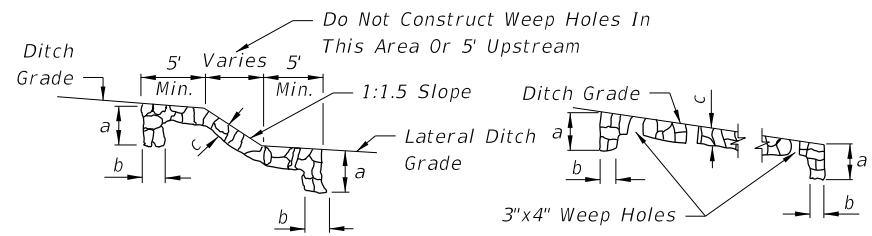

**SECTION AA PROFILE OF DITCH PAVEMENT AT LOCATIONS OTHER THAN JUNCTION WITH LATERAL DITCH**

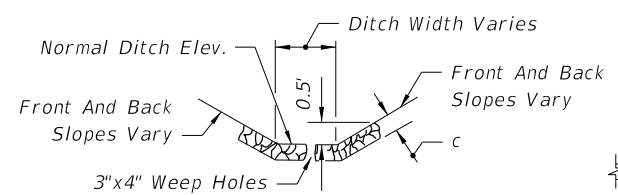

**TYPICAL SECTION**

**TABLE 1: DITCH PAVEMENT**

Pavement Type	Dimensions			Payment Unit	Basis Of Estimate	Filter Fabric Type	Velocity Range	References & Remarks
	a	b	c					
Concrete	24"	6"	3"	SY	SY	D-4*	Low-High	Section 524 of the Standard Specifications.
Miscellaneous Asphalt	24"	12"	4"	TN	0.2 TN/SY	None	Low-Moderate	Section 339.
Riprap (Sand-Cement)	24"	12"	4"	CY	0.11 CY/SY	D-4*	Low-Moderate	Section 530. Grouting of joints required.
Riprap (Ditch Lining)				TN	TN	D-2*	Moderate-High	Section 530.

\* Filter Fabric Required.

- GENERAL NOTES**
- Type of ditch pavement shall be as shown on plans.
  - In concrete ditch pavement, contraction joints are to be spaced at 25' maximum intervals, or as directed by the Engineer. Contraction joints may be either formed (construction joint) or tooled. No open joints will be permitted in concrete ditch pavement.  
  
Expansion joints with 1/2" preformed joint filler shall be constructed at all inlets, endwalls, and at intervals of not more than 200'.
  - Lip at end of ditch pavement shall normally be located downstream of DPI or on flatter grades where there is a decrease in ditch velocity.
  - Toewalls are to be used with all ditch paving. A toewall is not required adjacent to drainage structures.
  - When directed by the Engineer, weep hole spacing may be reduced to 5' minimum.
  - For junction of R/W ditch spillway and lateral ditch, sides of paving to be 1' high minimum.
  - For ditch pavements requiring filter fabric (See Table 1) place the filter fabric directly beneath the pavement for the entire length and width of the pavement. See Standard Specification Section 985 for fabric requirements and application.
  - When weep holes with aggregate are used, place filter fabric below the aggregate to form a mat continuous with the pavement filter fabric or underlapping the pavement filter fabric, if present.
  - Ditch pavement requiring reinforcement shall be detailed in the plans.
  - Cost of plastic filter fabric to be included in the contract unit price for ditch pavement.
  - Sodding to be paid for under contract unit price for Performance Turf, SY

10/16/2017 9:53:34 AM

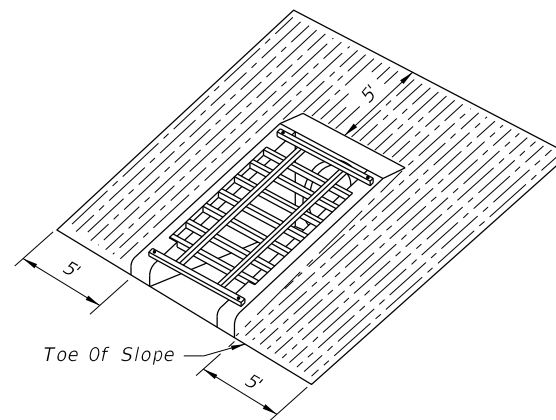
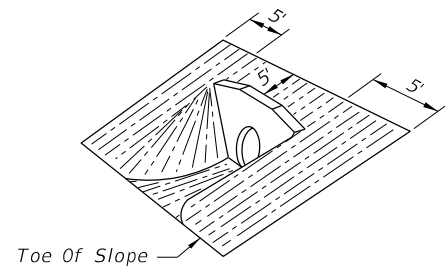
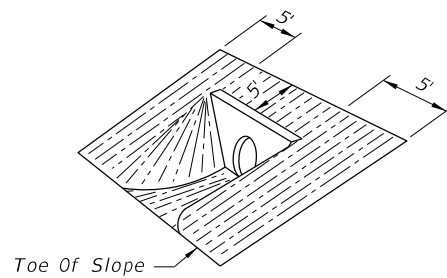

Note: Sodding quantities for each endwall to be determined by the designer from this detail.

(EXCEPT INDEX 430-030)  
STRAIGHT ENDWALL

STRAIGHT ENDWALL  
INDEX 430-030

U-TYPE ENDWALL  
INDEX 430-011

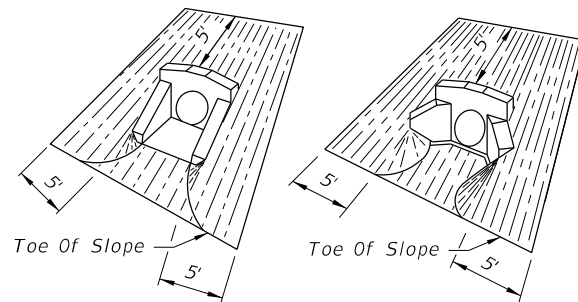

U-TYPE WINGS 45° WINGS  
WINGED ENDWALLS  
INDEX 430-040

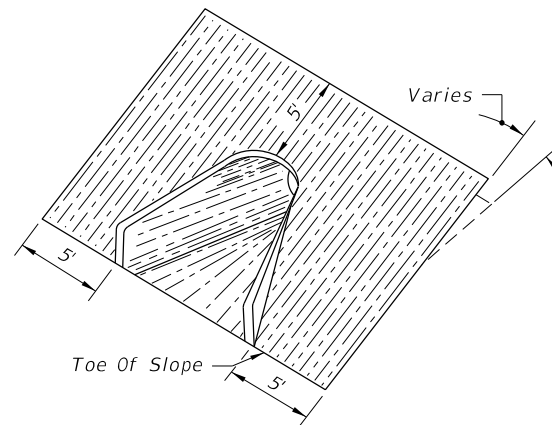

FLARED END SECTION  
INDEX 430-020

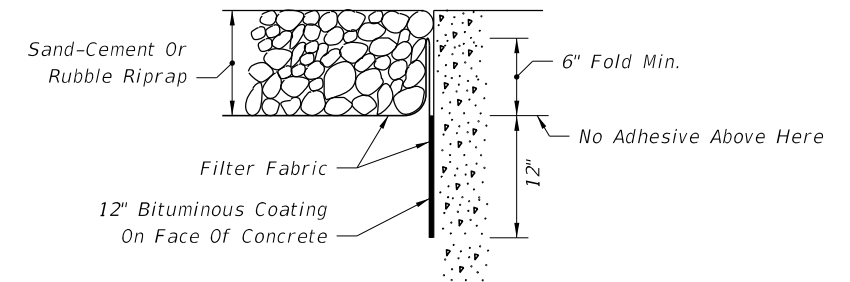

BONDED OPTION

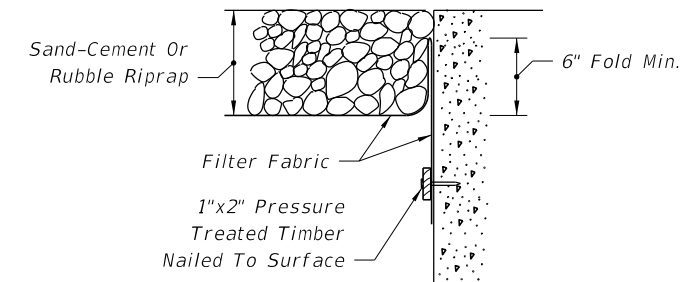

NAILED OPTION

Note: Either option may be used unless otherwise called for in the plans.

**FILTER FABRIC PLACEMENT AT CONCRETE STRUCTURE**

TABLE 2: SOD QUANTITIES (SY)

PIPE SIZE	INDEX 430-030												INDEX 430-011				INDEX 430-040				INDEX 430-020	
	SLOPE												SLOPE				SLOPE					ALL SLOPES
	1:2			1:3			1:4			1:6			1:2	1:3	1:4	1:6	1:2	1:3	1:4	1:6		
	PIPES												PIPES				PIPES					
	1	2	3	1	2	3	1	2	3	1	2	3	1	1	1	1	1	1	1	1	1	
12"																	14	15	18	22	10	
15"	19	21	24	22	26	29	26	30	33	34	38	43	13 (15)	16	17	23	15	17	20	25	11	
18"	21	24	27	25	29	33	30	34	38	39	44	50	14 (16)	17	19	25	16	18	22	28	11	
21"																					12	
24"	26	30	34	32	37	42	38	44	50	50	58	66	15 (17)	19	21	28	19	22	26	34	14	
27"																					15	
30"	31	37	42	39	46	53	46	55	63	62	74	85	17 (18)	21	24	32	21	25	30	40	16	
36"	37	44	52	46	56	65	56	67	79	76	91	107					24	29	35	47	18	
42"	43	53	62	55	67	79	67	82	96	91	111	132					27	32	39	54	19	
48"	50	62	73	64	79	93	78	97	115	108	133	158					30	36	44	61	21	
54"	57	71	85	74	92	110	91	113	136	126	157	188									21	
60"																					22	
66"																					25	
72"																					26	

( ) Endwall With Baffles

**SOD PLACEMENT AT PIPE/CULVERT END TREATMENTS**

10/16/2017 9:53:34 AM