

C-I-P COPING - PARTIAL ELEVATION VIEW

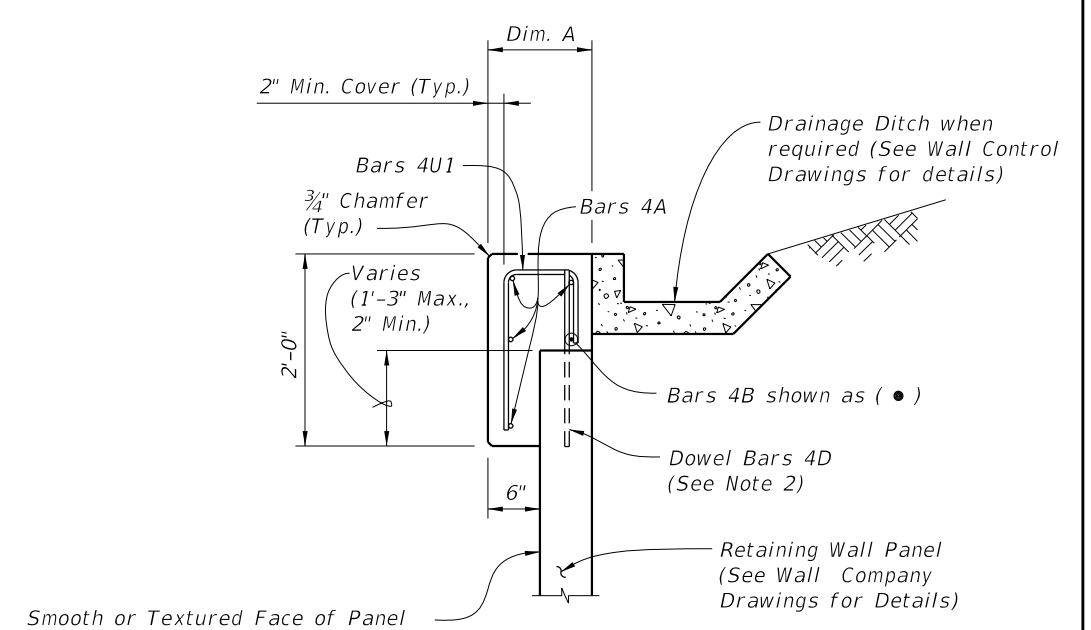

SECTION A-A  
C-I-P COPING

Dim. A	Panel width + 6"
Dim. B	Panel width + 1'-0" Min.

PRECAST AND C-I-P COPING NOTES:

1. Provide Class II concrete for slightly aggressive environments or Class IV for moderately or extremely aggressive environments.
2. Dowel Bars 4D extend 11" above the top of retaining wall panel. Field cut as necessary to maintain 2" minimum cover. See Wall Company Drawings for number and spacing of Dowel Bars 4D.
3. Payment for Dowel Bars 4D, Buildup Concrete and Coping will be made under Retaining Wall System (Permanent).

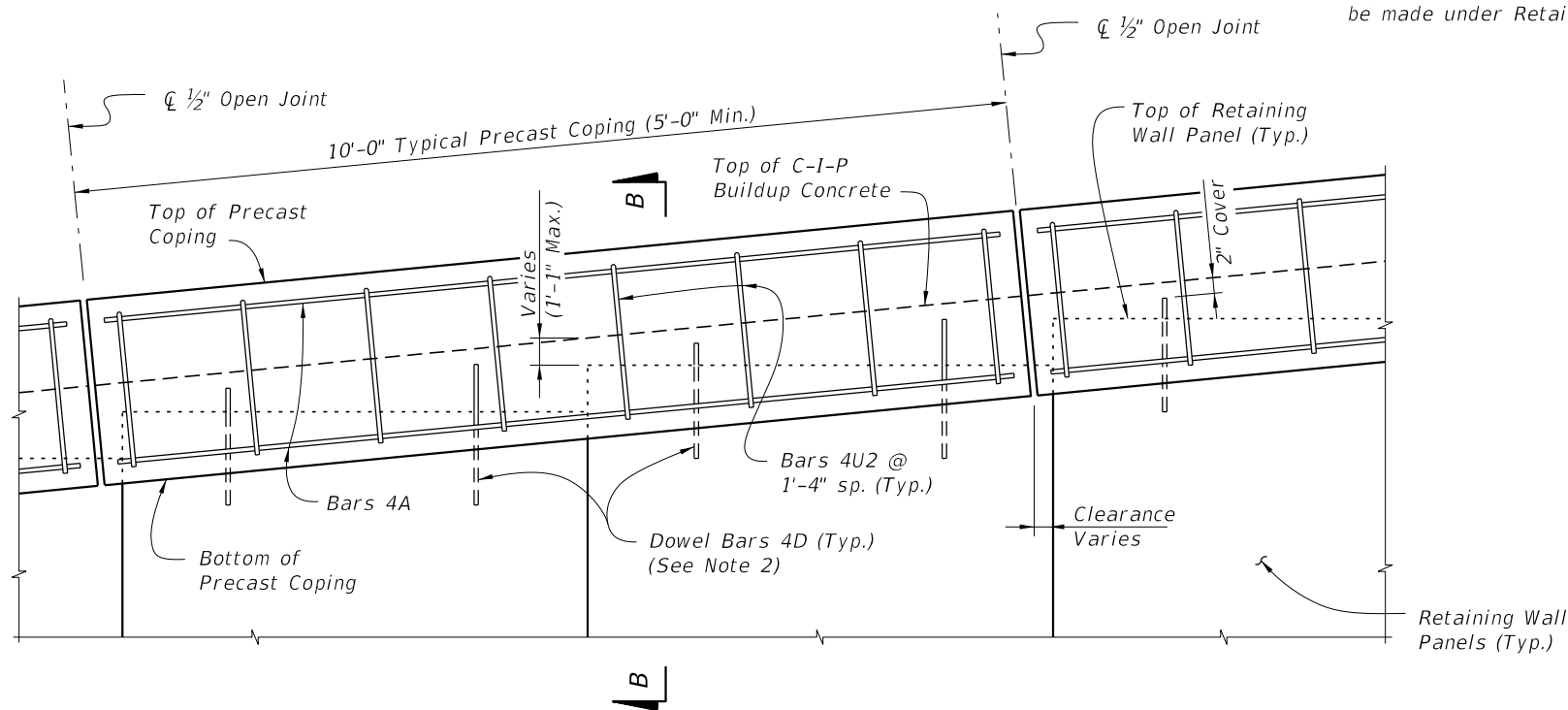

PRECAST COPING - PARTIAL ELEVATION VIEW

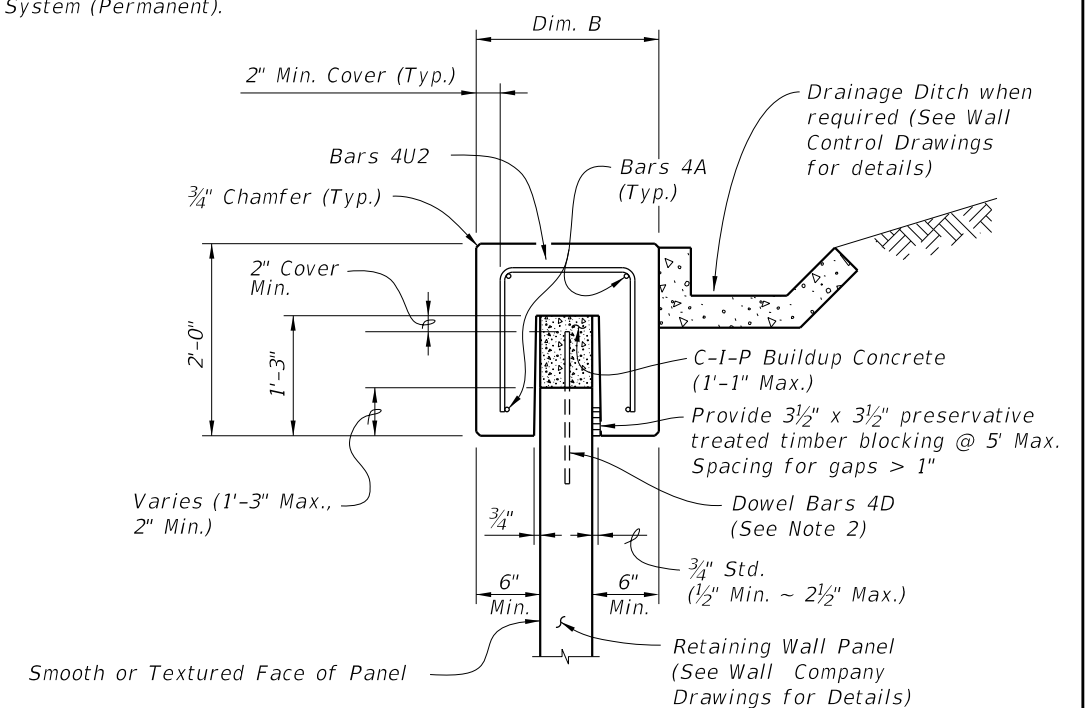

SECTION B-B  
PRECAST COPING

10/25/2017 4:09:23 PM

LAST REVISION 07/01/14	DESCRIPTION:
---------------------------	--------------



FY 2018-19  
STANDARD PLANS

MSE WALL COPING (PRECAST OR C-I-P)

INDEX  
521-600

SHEET  
1 of 2

**REINFORCING STEEL BENDING DIAGRAMS - PRECAST AND C-I-P COPINGS**

**BILL OF REINFORCING STEEL**

MARK	SIZE	LENGTH (L) ## S or M	LENGTH (L) ## E
A	4	AS REQD.	AS REQD.
B	4	AS REQD.	AS REQD.
D	4	2'-0"	2'-0"
U1	4	Panel width + 4"	Panel width + 4"
U2	4	Dim. B - 4"	Dim. B - 4"
U3	4	Dim. C - 4"	Dim. C - 6"

**REINFORCING STEEL NOTES:**

- All bar dimensions in the bending diagrams are out to out.
- All reinforcing steel at the open joints will have a 2" minimum cover.
- Bars 4A may be continuous or spliced at the construction joints. Lap splices for Bars 4A will be a minimum of 1'-8".
- The Contractor may use Welded Wire Reinforcement (WWR) when approved by the Engineer. WWR must consist of Deformed wire meeting the requirements of Specification Section 931.

## S = Slightly Aggressive  
 M = Moderately Aggressive  
 E = Extremely Aggressive

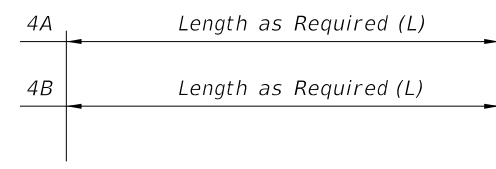

**BARS 4A & 4B**



**DOWEL BAR 4D**

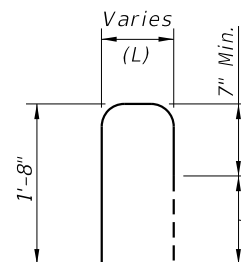

**BAR 4U1**

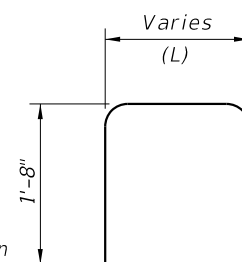

**BAR 4U2**

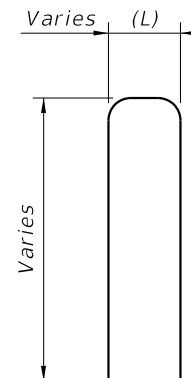

**BAR 4U3**

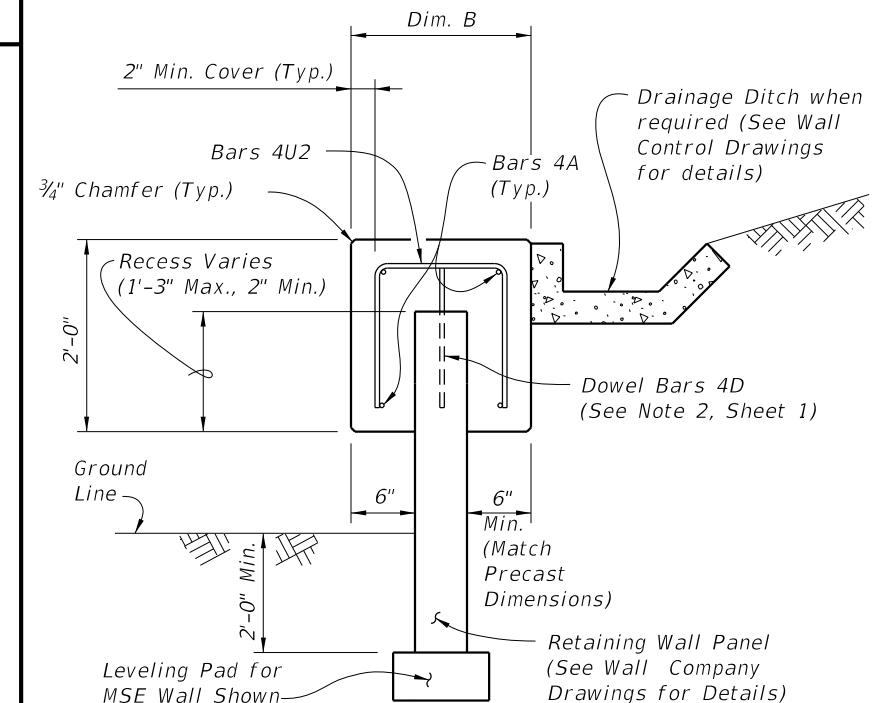

**C-I-P COPING USED WITH PRECAST COPING**

Note: When precast coping units do not fit the entire length of the retaining wall, use this similar C-I-P coping for short portions between precast coping units. This C-I-P coping may also be used for vertical copings.

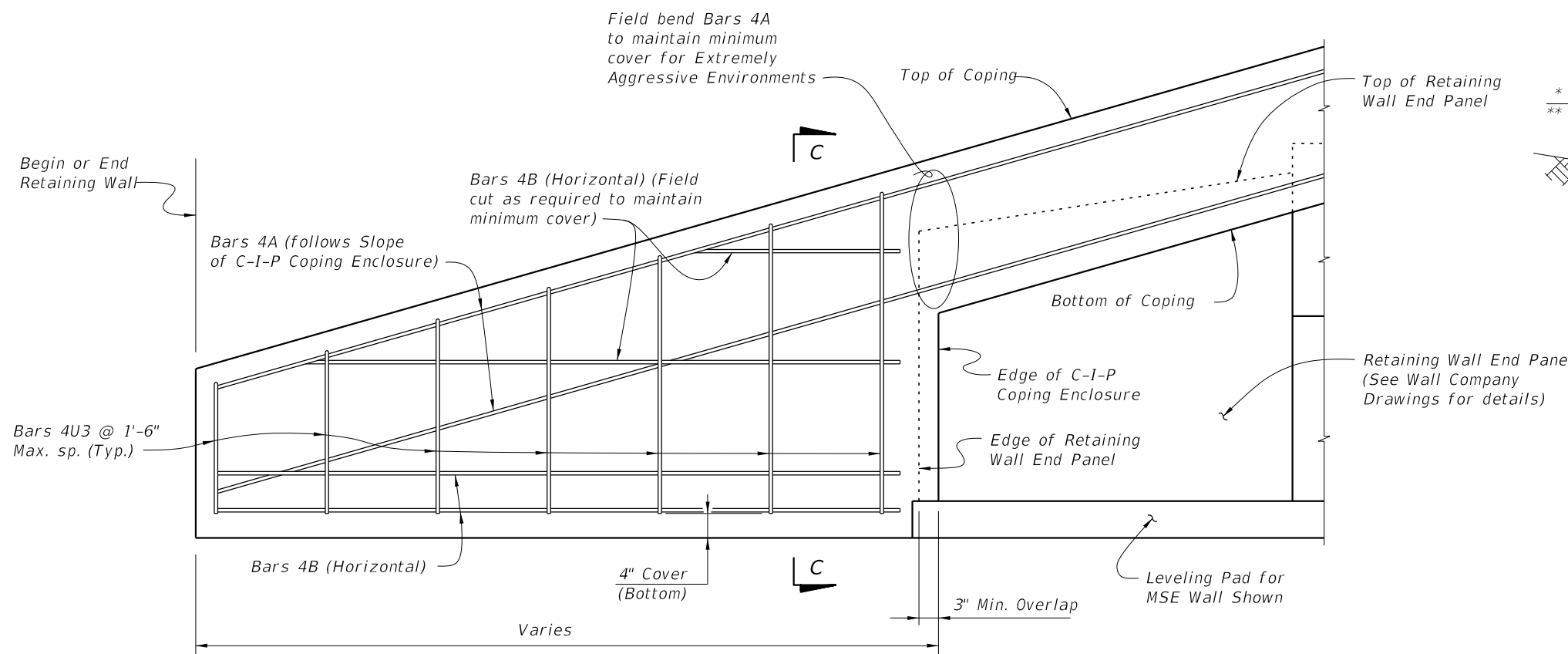

**C-I-P COPING ENCLOSURE DETAIL**

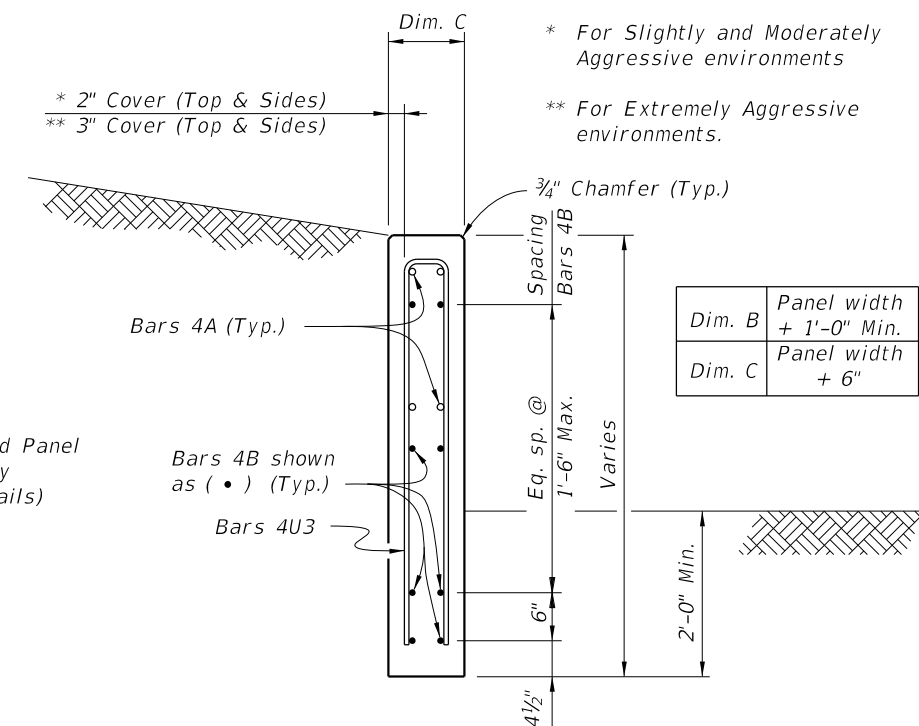

**SECTION C-C**

10/25/2017 4:09:23 PM

LAST REVISION 07/01/13	DESCRIPTION:
---------------------------	--------------



**FY 2018-19  
STANDARD PLANS**

**MSE WALL COPING (PRECAST OR C-I-P)**

INDEX  
**521-600**

SHEET  
**2 of 2**