

PLAN

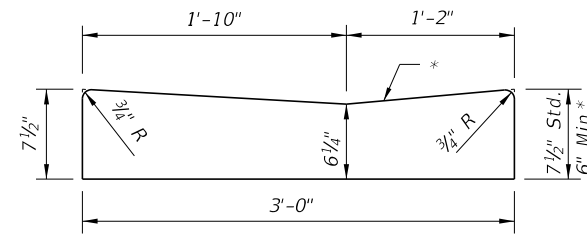

SECTION AA

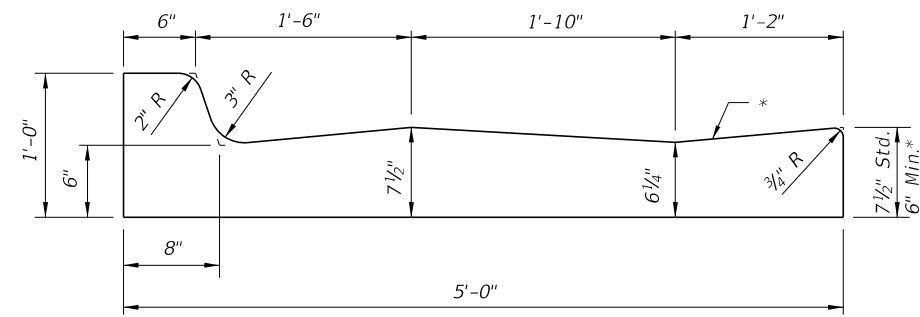

SECTION BB

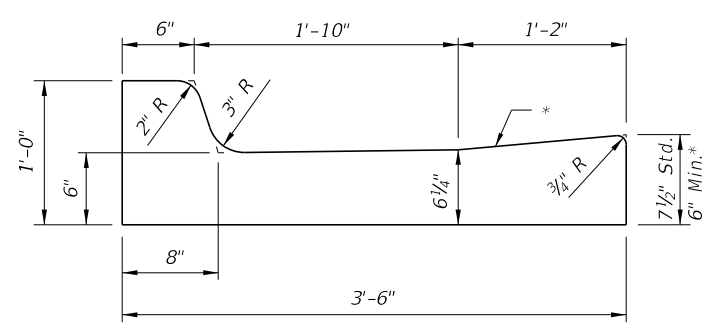

SECTION CC

VALLEY GUTTER

* When used on high side of roadways, the cross slope of the gutter shall match the cross slope of the adjacent pavement. The thickness of the lip shall be 6", unless otherwise shown on plans.

▣ Rotate entire section so that gutter cross slope matches slope of adjacent circulating roadway pavement.

For use adjacent to concrete or flexible pavement. For details depicting usage adjacent to flexible pavement, see Sheet 2. Expansion joint, preformed joint filler and joint seal are required between curb & gutter and concrete pavement only, see Sheet 2.

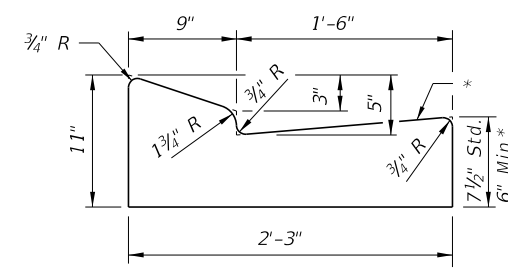

TYPE E

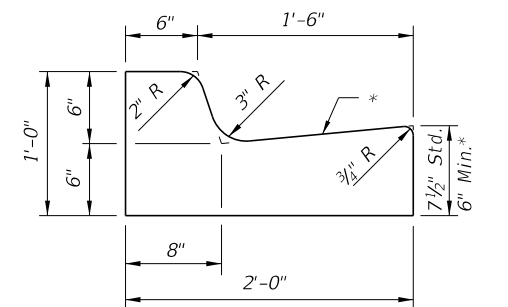

TYPE F

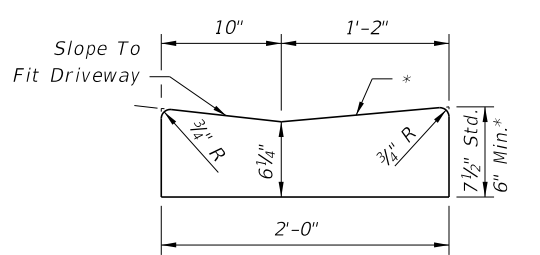

DROP CURB

Note: To be paid for as parent curb.

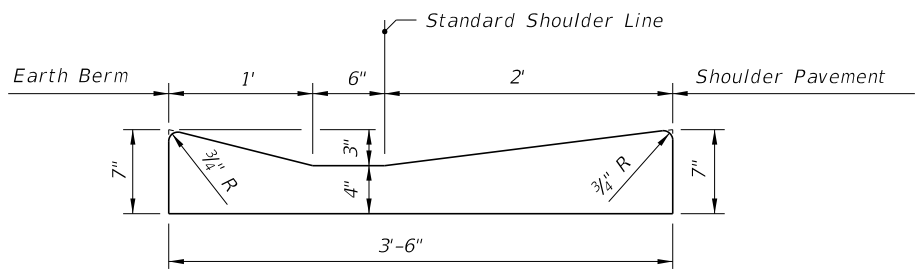

SHOULDER GUTTER

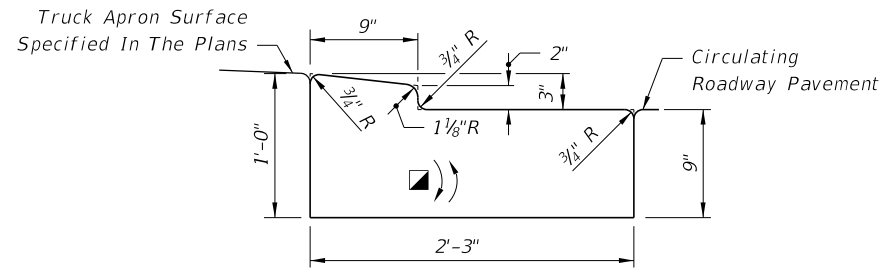

TRAFFIC BEARING SECTION FOR USE IN ROUNDABOUT CENTRAL ISLAND CONSTRUCTION TYPE RA

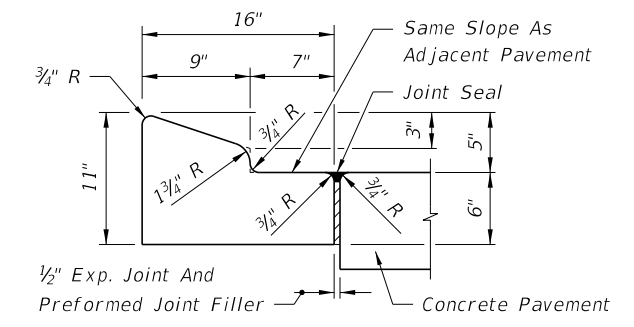

TYPE A

For details depicting usage adjacent to flexible pavement, see Sheet 2.

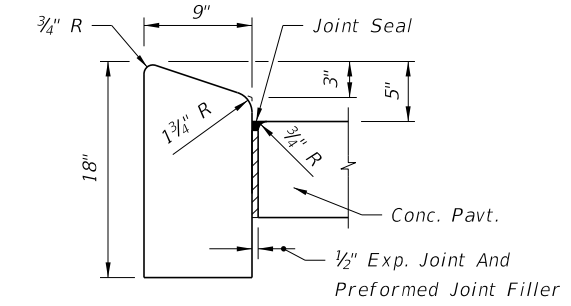

TYPE B

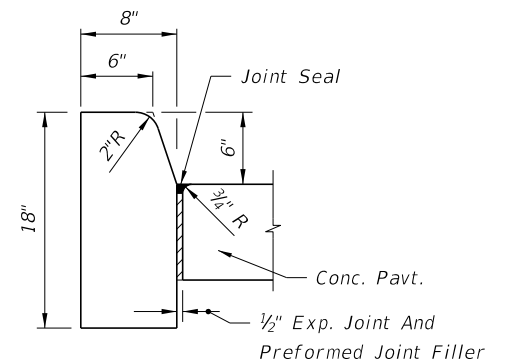

TYPE D

Note: For use adjacent to concrete or flexible pavement, concrete shown. Expansion joint, preformed joint filler and joint seal are required between curbs and concrete pavement only, see Sheet 2.

CONCRETE CURB

CONCRETE CURB AND GUTTER

3/20/2018 2:15:04 PM

LAST REVISION 11/01/17	REVISION	DESCRIPTION:		FY 2018-19 STANDARD PLANS	CURB AND GUTTER	INDEX 520-001	SHEET 1 of 2
---------------------------	----------	--------------	--	------------------------------	-----------------	------------------	-----------------

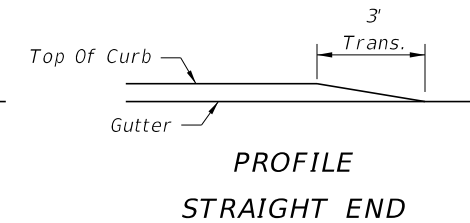
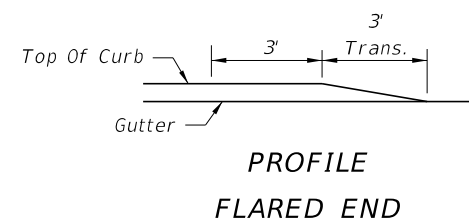
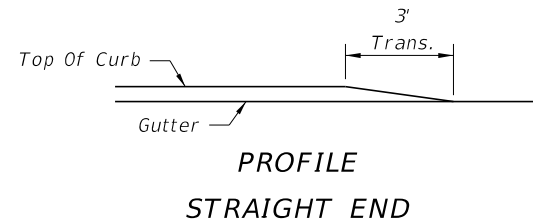
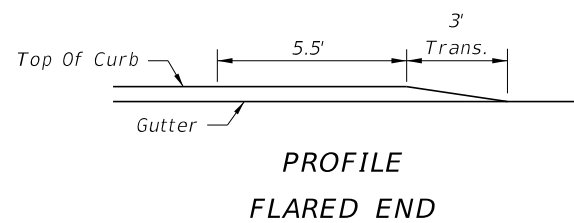
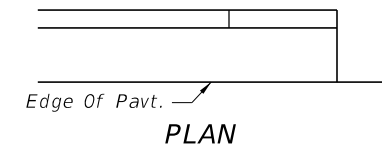
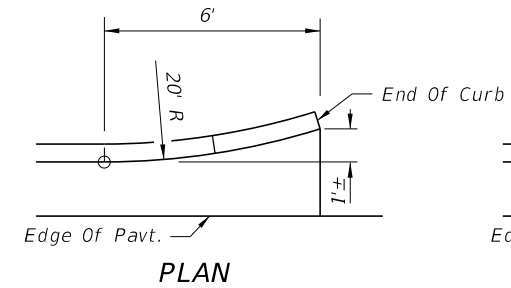
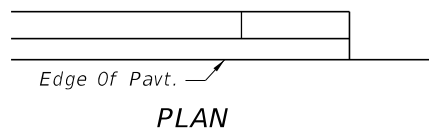
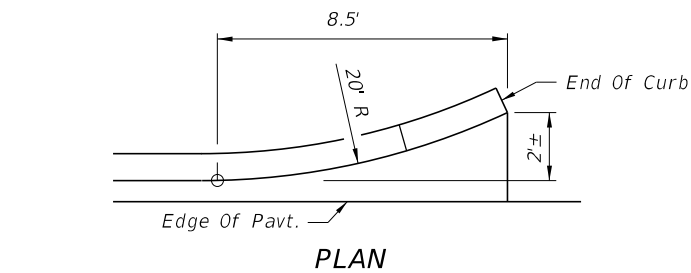

CURB TYPE A

CURB AND GUTTER ENDINGS

CURB AND GUTTER TYPES E & F

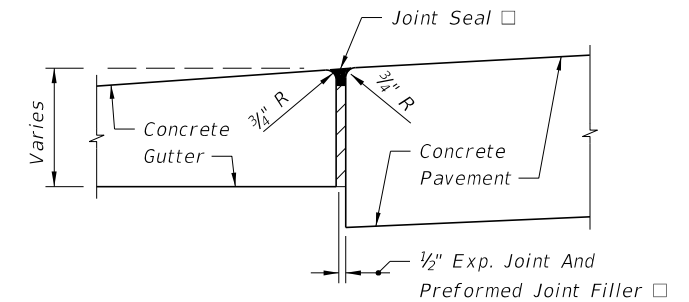
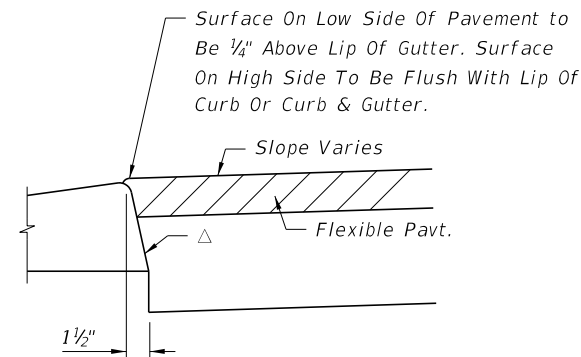
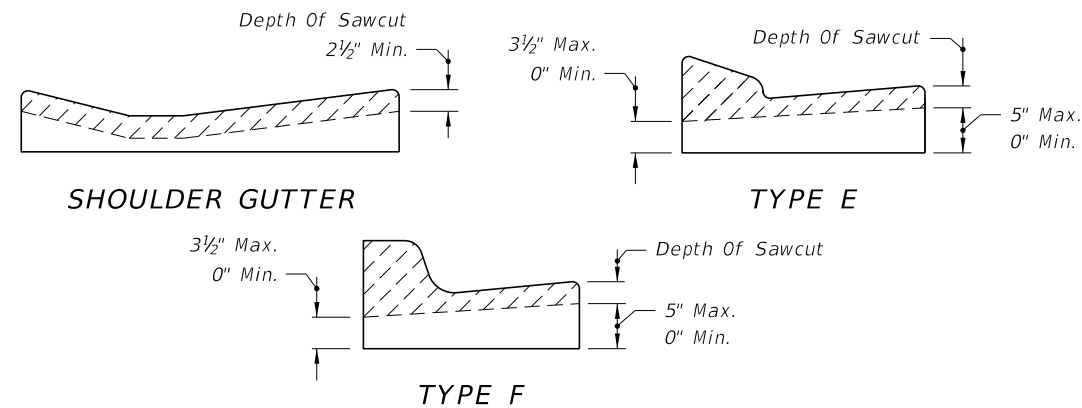

□ Applies to both high and low sides of pavement, low side shown.

EXPANSION JOINT BETWEEN GUTTER AND CONCRETE PAVEMENT

CONTRACTION JOINT IN CURB AND GUTTER

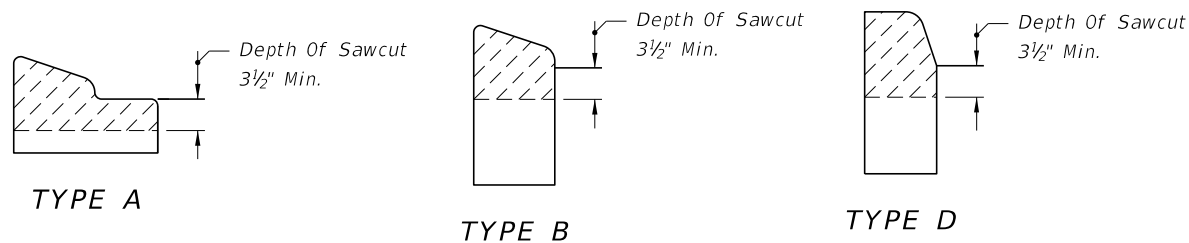

CONTRACTION JOINT IN CURB

CURB AND GUTTER AND TYPE A CURB ADJACENT TO FLEXIBLE PAVEMENT

△ Applies to both high and low sides of pavement, low side shown.
Applies to shoulder gutter only where adjoining traffic lanes.

GENERAL NOTES

1. For curb, gutter and curb & gutter provide 1/8" - 1/4" contraction joints at 10' centers (max.). Contraction joints adjacent to concrete pavement on tangents and flat curves are to match the pavement joints, with intermediate joints not to exceed 10' centers. Curb, gutter and curb & gutter expansion joints shall be located in accordance with Section 520 of the Standard Specifications.
2. Ends of Curbs Types B and D shall transition from full to zero heights in 3'.

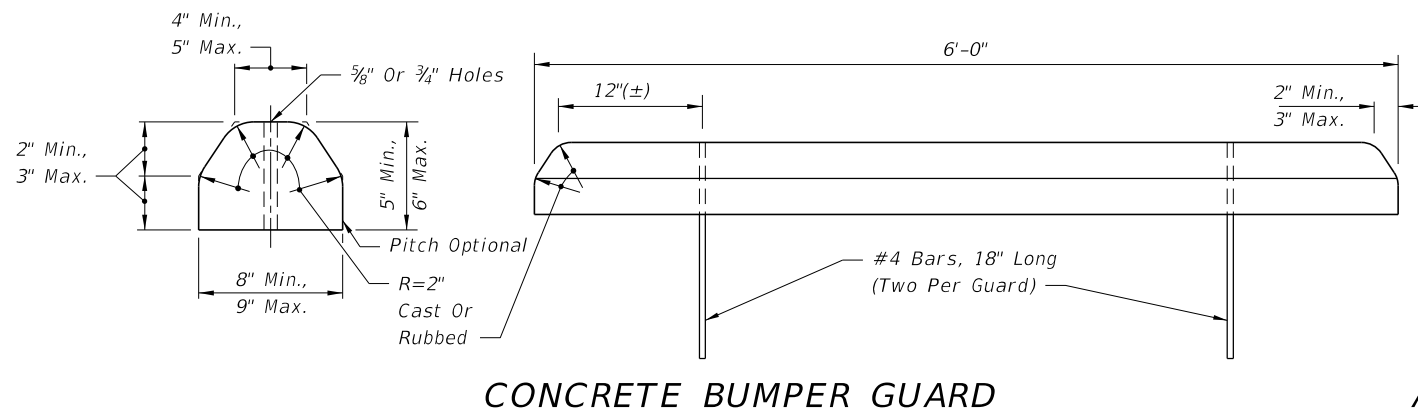

CONCRETE BUMPER GUARD

ASPHALTIC CONCRETE CURB

10/16/2017 9:42:32 AM

LAST REVISION 11/01/17	DESCRIPTION:	FDOT FY 2018-19 STANDARD PLANS	CURB AND GUTTER	INDEX 520-001	SHEET 2 of 2
---------------------------	--------------	--------------------------------------	-----------------	------------------	-----------------