

ELEVATION

** See Note 4 on Index 455-102

ALTERNATE STRAND PATTERNS

- 12 ~ 0.6" Ø, CFRP 7-Strand, at 34 kips
- 12 ~ 1/2" Ø, CFRP Single-Strand, at 33 kips

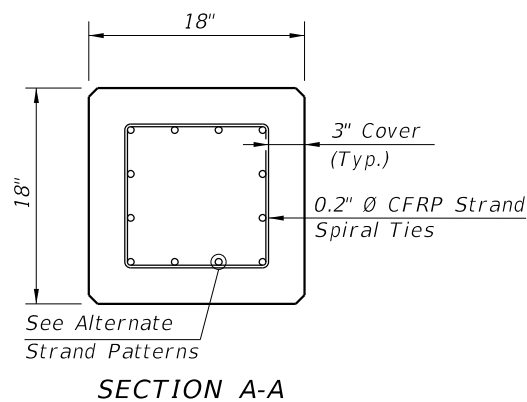

NOTES:

- Work this Index with Index 455-101 - Typical Details and Notes for Square CFRP & SS Prestressed Concrete Piles and Index 455-102 - Square CFRP & SS Prestressed Concrete Pile Splices.
- Any of the given Strand Patterns may be utilized. The strands shall be located as follows:
Place one strand at each corner and place the remaining strands equally spaced between the corner strands. The total strand pattern shall be concentric with the nominal concrete section of the pile.

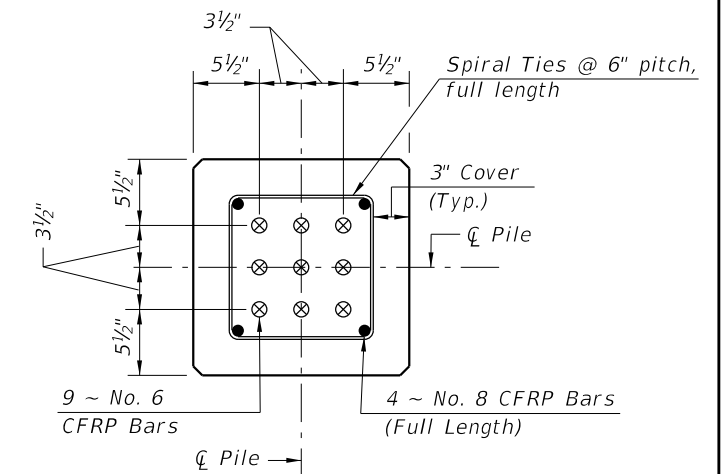

SECTION D-D

(See Nondrivable Unforeseen Reinforced Precast Pile Build-Up Detail)

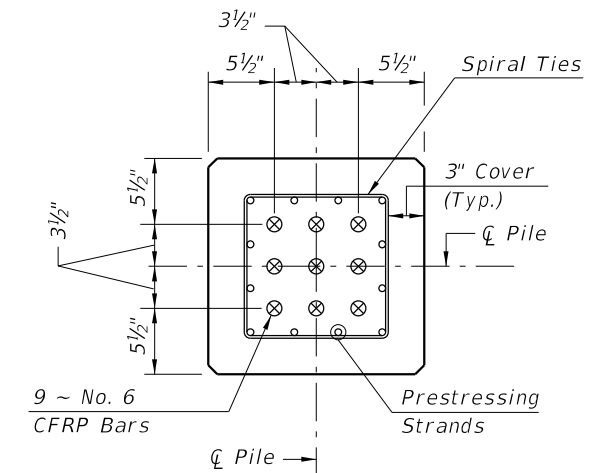

SECTION E-E

(See Drivable Prestressed Precast Splice Detail)

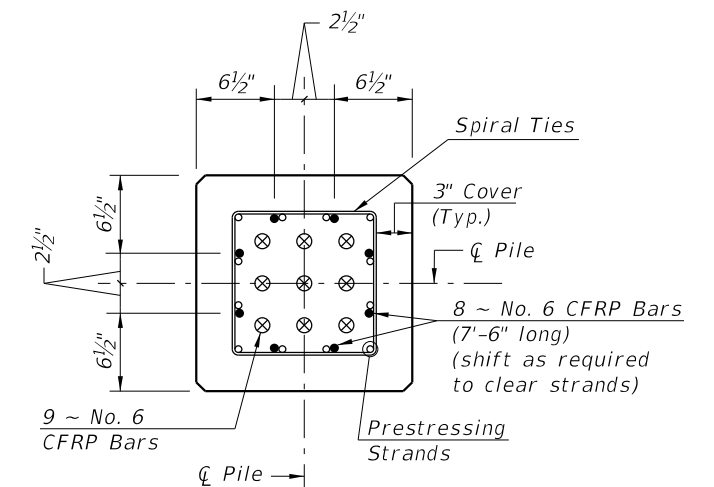

SECTION F-F

(See Drivable Preplanned Prestressed Precast Splice Detail)

CFRP PILE SPLICE REINFORCEMENT DETAILS

CFRP PRESTRESSED PILE DETAILS

10/26/2017 8:21:42 AM

LAST REVISION 11/01/16	DESCRIPTION:		FY 2018-19 STANDARD PLANS	18" SQUARE CFRP & SS PRESTRESSED CONCRETE PILE	INDEX 455-118	SHEET 1 of 2

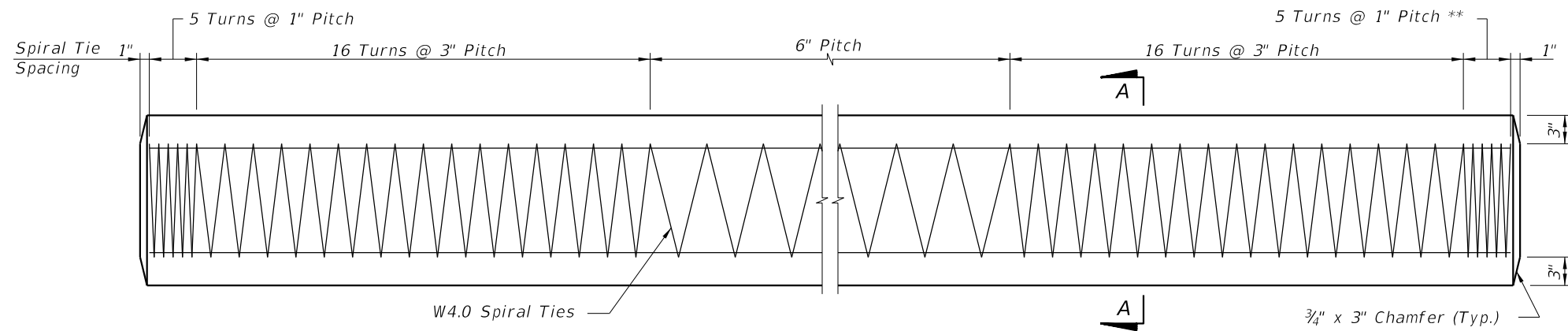

ELEVATION

** See Note 4 on Index 455-102

STRAND PATTERN

16 ~ 1/2" Ø, HSSS, at 26 kips

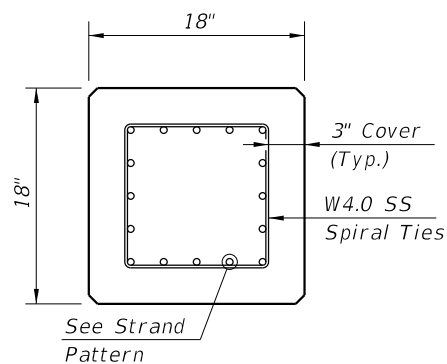

SECTION A-A

NOTES:

1. Work this Index with Index 455-101 - Typical Details and Notes for Square CFRP & SS Prestressed Concrete Piles and Index 455-102 - Square CFRP & SS Prestressed Concrete Pile Splices.
2. Any of the given Strand Patterns may be utilized.
The strands shall be located as follows:
Place one strand at each corner and place the remaining strands equally spaced between the corner strands.
The total strand pattern shall be concentric with the nominal concrete section of the pile.

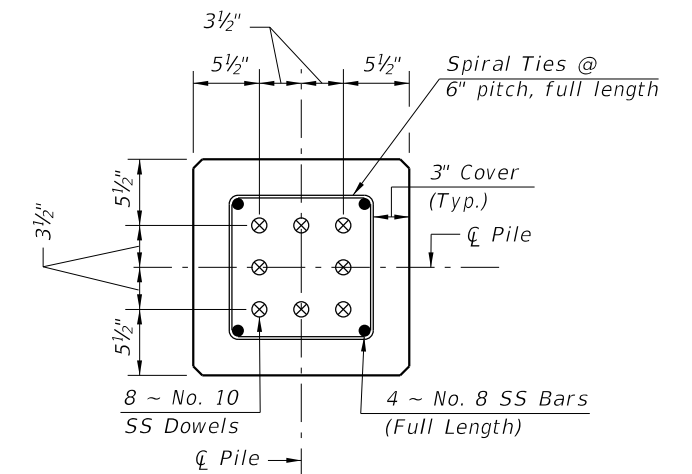

SECTION D-D

(See Non-drivable Unforeseen Reinforced Precast Pile Build-Up Detail)

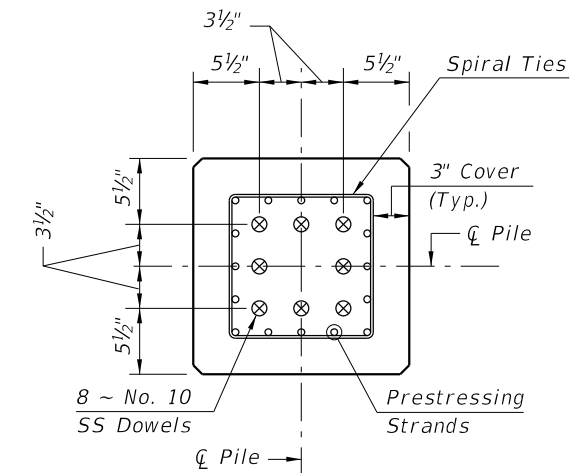

SECTION E-E

(See Drivable Prestressed Precast Splice Detail)

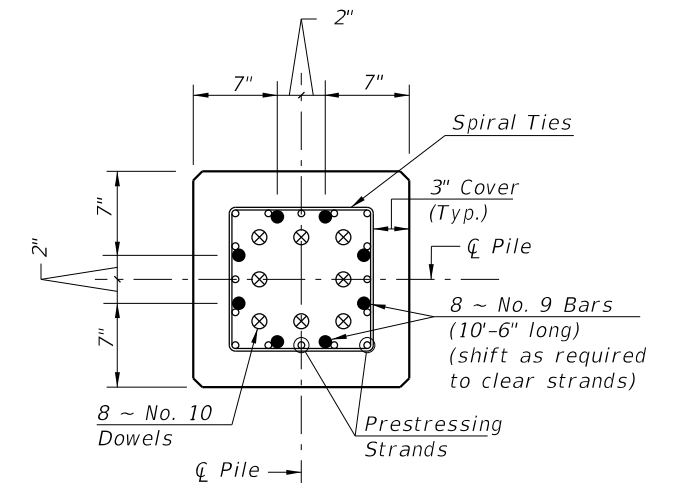

SECTION F-F

(See Drivable Preplanned Prestresses Precast Splice Detail)

SS PILE SPLICE REINFORCEMENT DETAILS

SS PRESTRESSED PILE DETAILS

10/26/2017 8:21:42 AM

LAST REVISION 01/01/16	DESCRIPTION:		FY 2018-19 STANDARD PLANS	18" SQUARE CFRP & SS PRESTRESSED CONCRETE PILE	INDEX 455-118	SHEET 2 of 2