

TYPICAL SECTION

\* Reinforcing steel is symmetrical about  $\bar{C}$  Beam for Half Sections A-A and B-B.  
 \*\* Intermediate Diaphragms shall be provided:  
 (1) - At midspan.  
 (2) - At 20'-0" Max. from midspan when beam length (L) exceeds 60 Ft.

NOTES:  
 Work this Index with Index 450-210 - Typical Florida-U Beam Details and Notes and the Florida-U Beam - Table of Beam Variables in Structures Plans.  
 For referenced notes see Index 450-210.

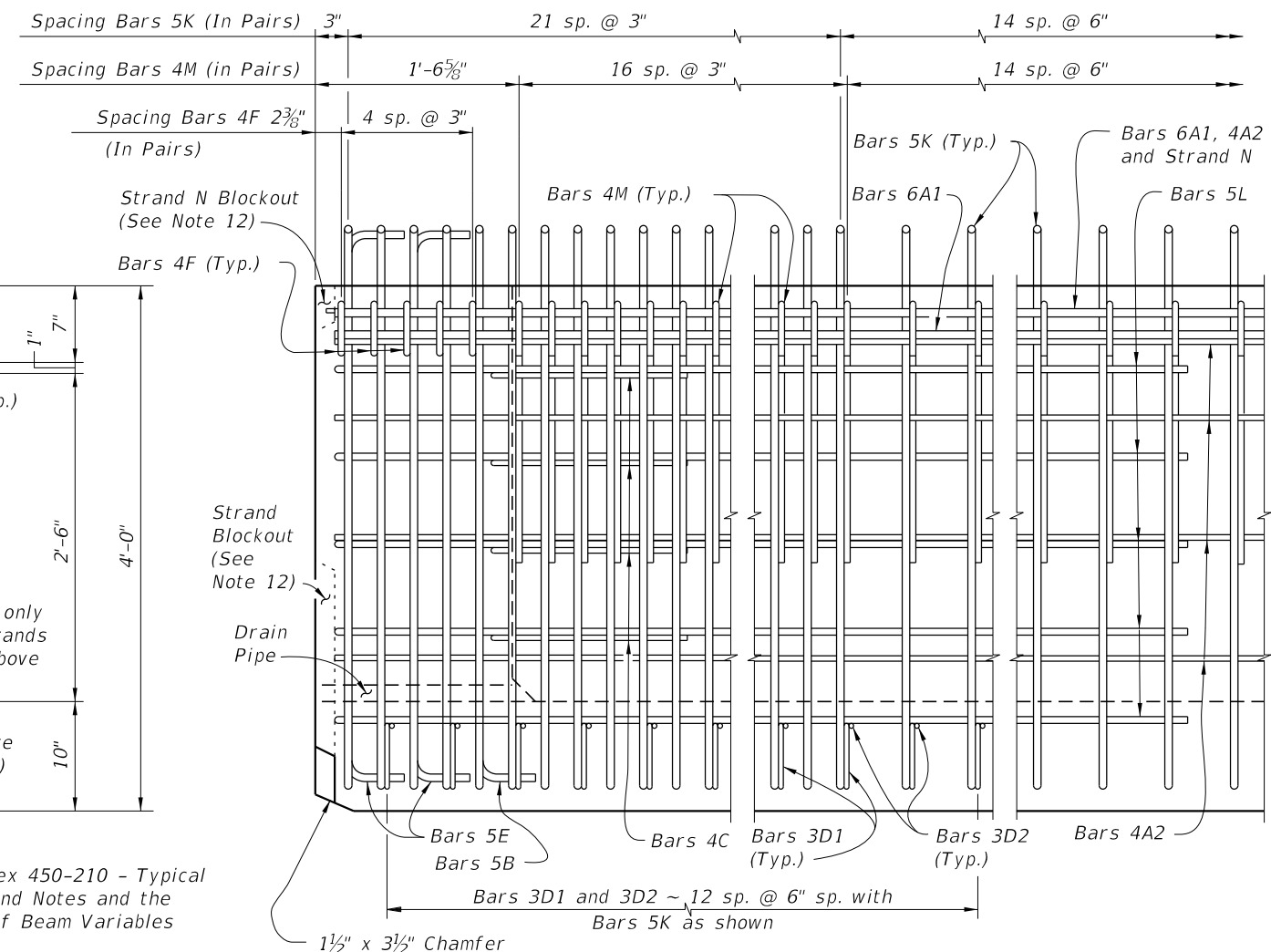

ELEVATION AT END OF BEAM

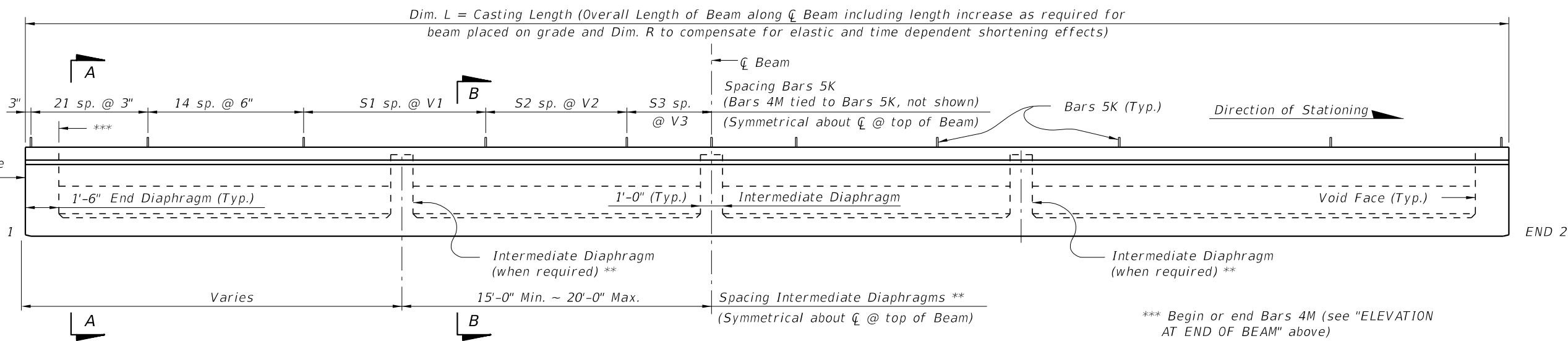

ELEVATION

\*\*\* Begin or end Bars 4M (see "ELEVATION AT END OF BEAM" above)

10/26/2017 8:29:13 AM

LAST REVISION 11/01/16	DESCRIPTION:	 FY 2018-19 STANDARD PLANS	FLORIDA-U 48 BEAM - STANDARD DETAILS	INDEX 450-248	SHEET 1 of 3
---------------------------	--------------	----------------------------------	--------------------------------------	------------------	-----------------

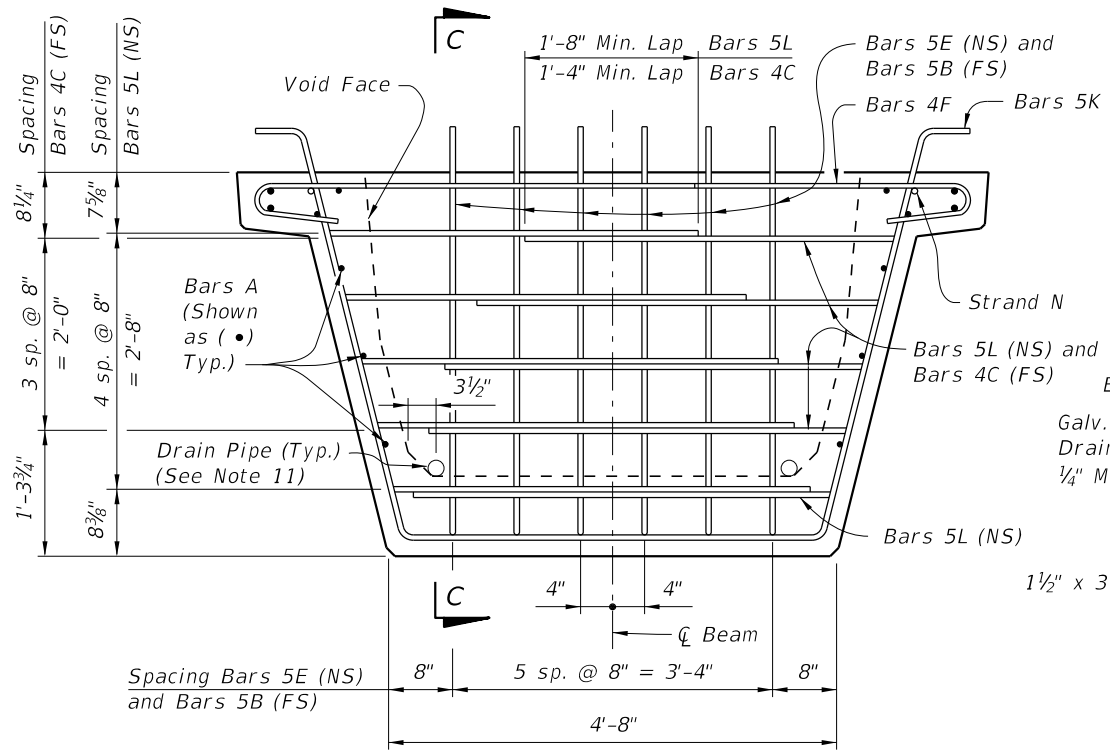

END VIEW AT END DIAPHRAGM

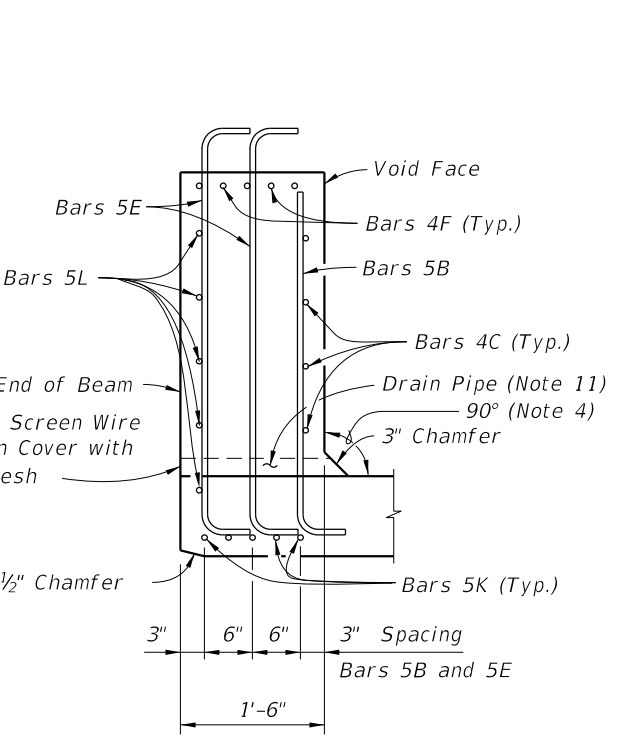

SECTION C-C

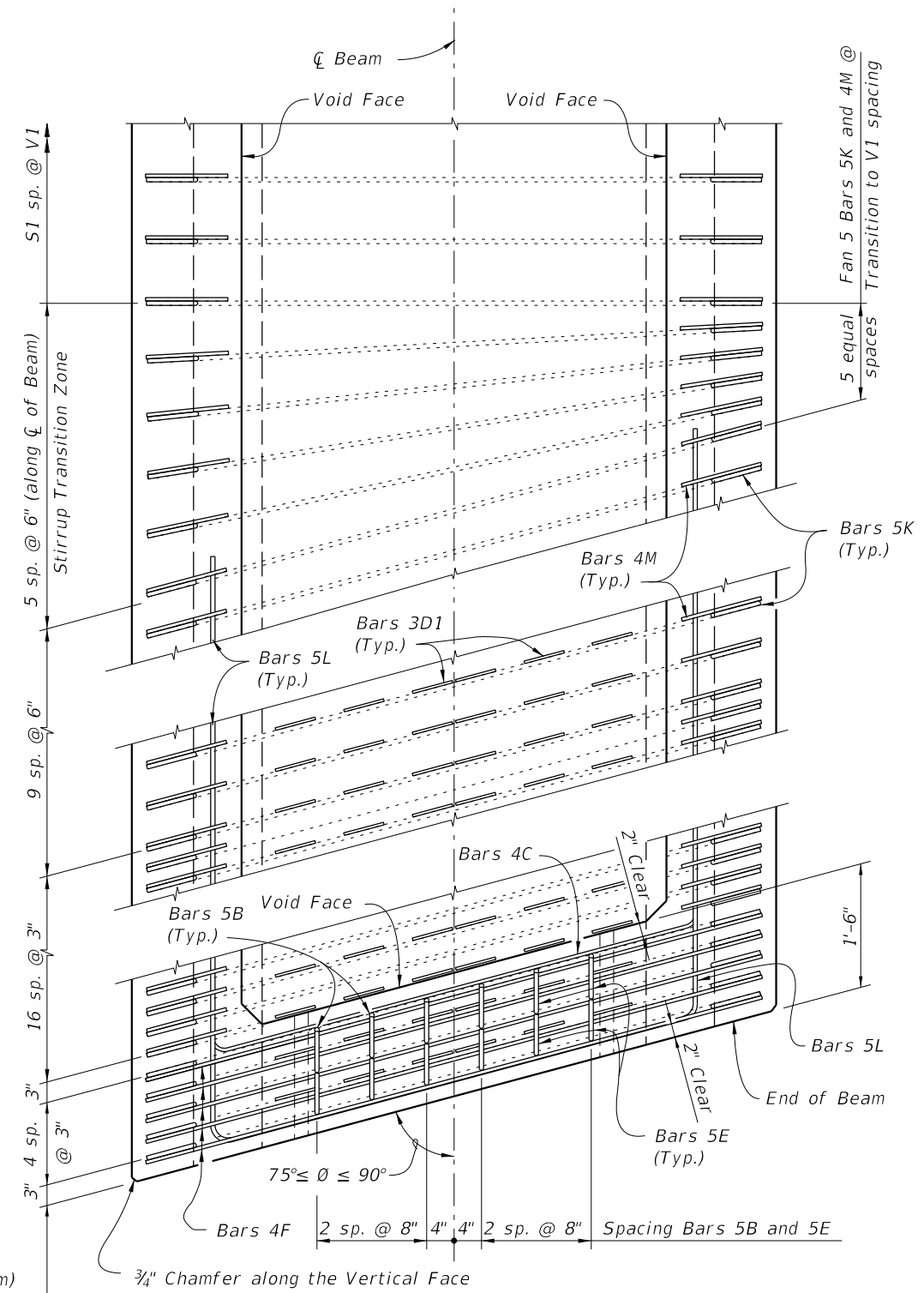

TOP VIEW OF SKEWED END DIAPHRAGM AND STIRRUP TRANSITION ZONE (Bars 3D2 Not Shown For Clarity)

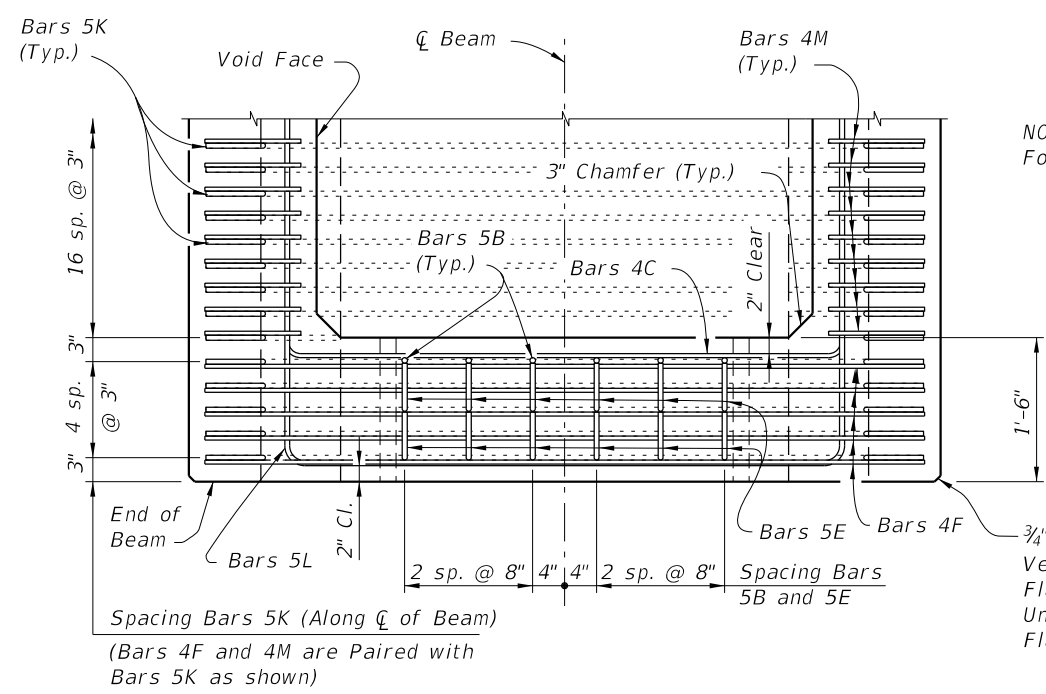

TOP VIEW OF END DIAPHRAGM (Bars 3D1 And 3D2 Not Shown For Clarity)

NOTES:  
For referenced notes see Index 450-210.

Spacing Bars 5K (Along centerline of Beam)  
(Bars 4F and 4M are Paired with Bars 5K as shown)

3/4" Chamfer along the Vertical Face of the Top Flange and Web and Underside of the Top Flange (Typ.)

10/26/2017 8:29:14 AM

LAST REVISION 11/01/16	DESCRIPTION:	 FY 2018-19 STANDARD PLANS	FLORIDA-U 48 BEAM - STANDARD DETAILS	INDEX 450-248	SHEET 2 of 3
---------------------------	--------------	--	--------------------------------------	------------------	-----------------

CONVENTIONAL REINFORCING STEEL BENDING DIAGRAMS

BILL OF REINFORCING STEEL FOR ONE BEAM ONLY

MARK	SIZE	NO. REQD.	LENGTH
A1	6	4	Dim. L - 4"
A2	4	10	Dim. L - 4"
B	5	12	4'-1"
C	4	16	5'-1"
D1	3	156	1'-6"
D2	3	26	4'-6"
E	5	24	5'-3"
F	4	20	6'-2"
G	4	See Table	4'-0"
H	4	See Table	4'-7"
K	5	See Table	8'-0"
L	5	20	14'-0"
M	4	See Table	3'-11"
N	3/8" Ø Strand	2	Dim. L - 3"

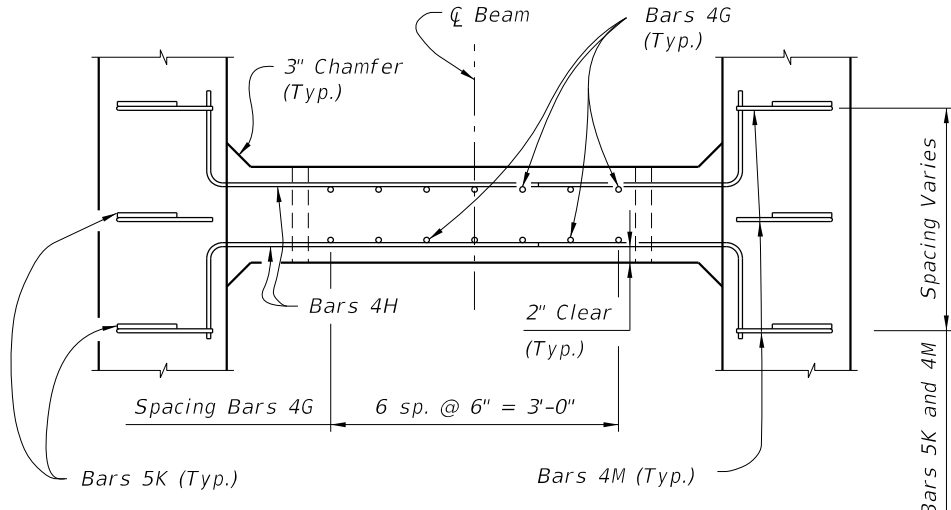
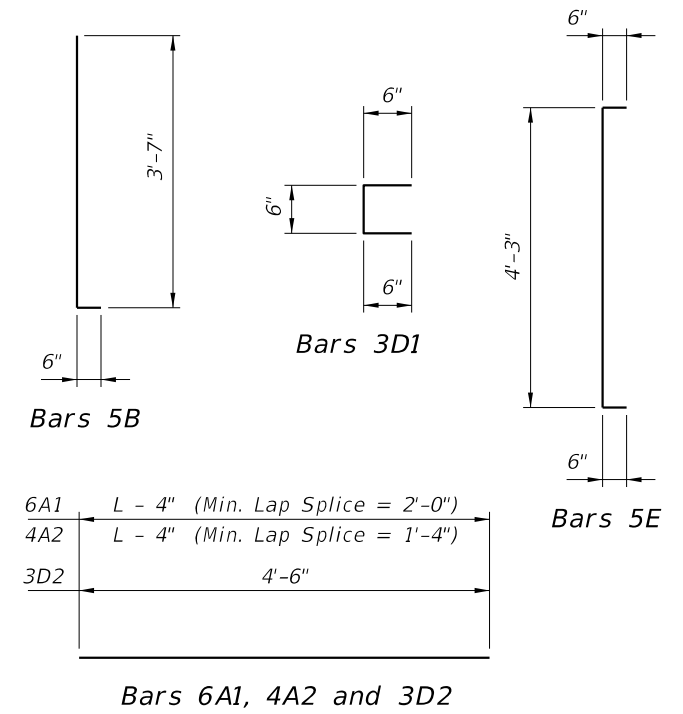

TOP VIEW OF INTERMEDIATE DIAPHRAGM

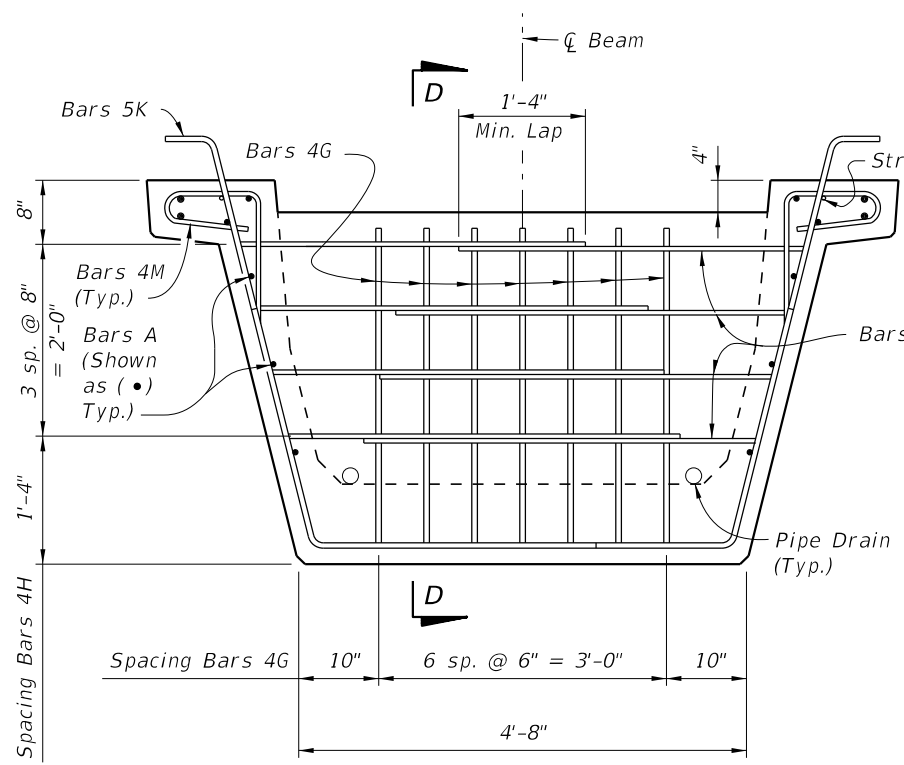

SECTION AT INTERMEDIATE DIAPHRAGM

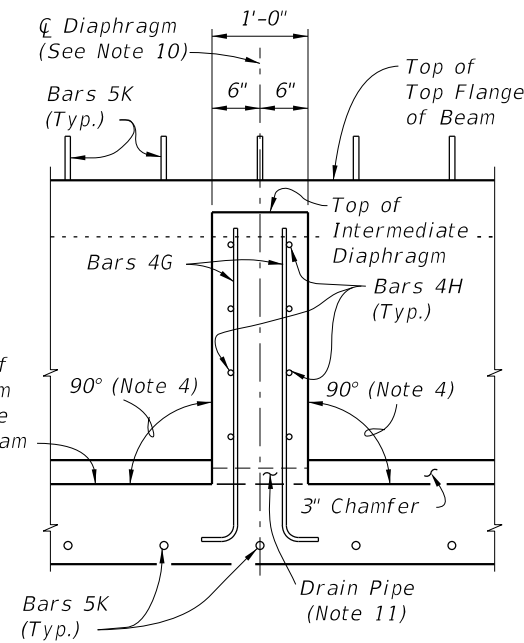

SECTION D-D

NOTES:  
For referenced notes see Index 450-210.

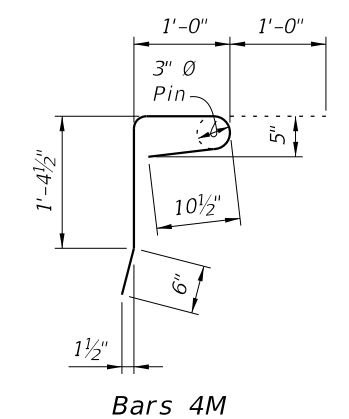
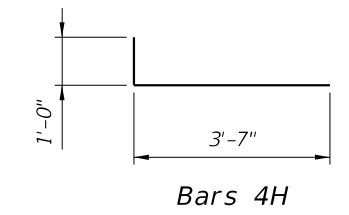
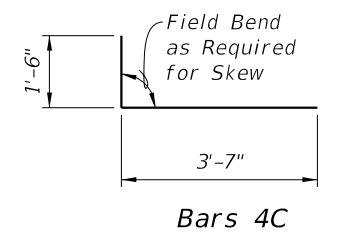
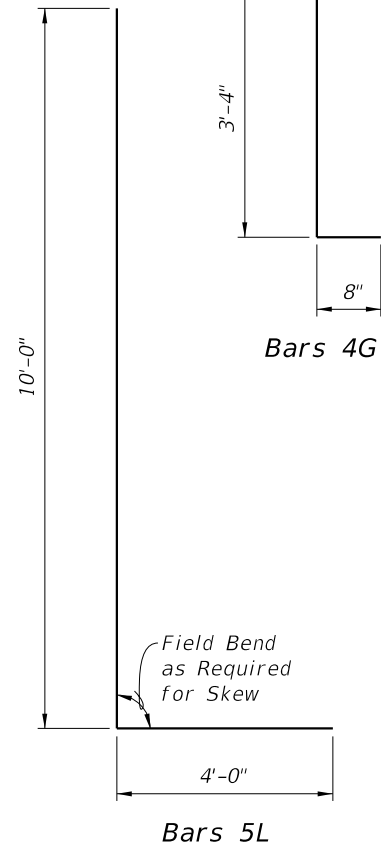
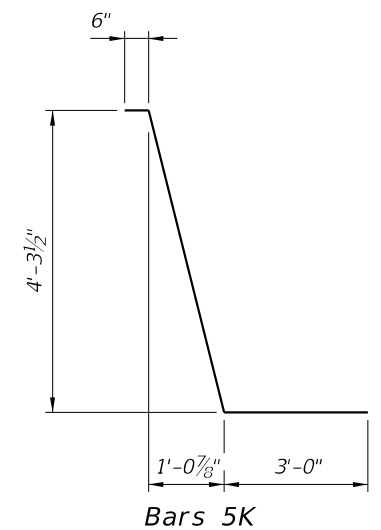
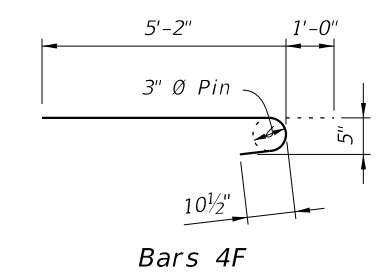

10/26/2017 8:29:14 AM

LAST REVISION 11/01/16	DESCRIPTION:
---------------------------	--------------



FY 2018-19  
STANDARD PLANS

FLORIDA-U 48 BEAM - STANDARD DETAILS

INDEX  
450-248

SHEET  
3 of 3