

SIDE ELEVATION

FRONT ELEVATION

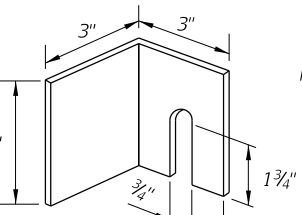

ANGLE DETAIL

Angles on other side of skimmer are mirror image.

TYPE I SKIMMER

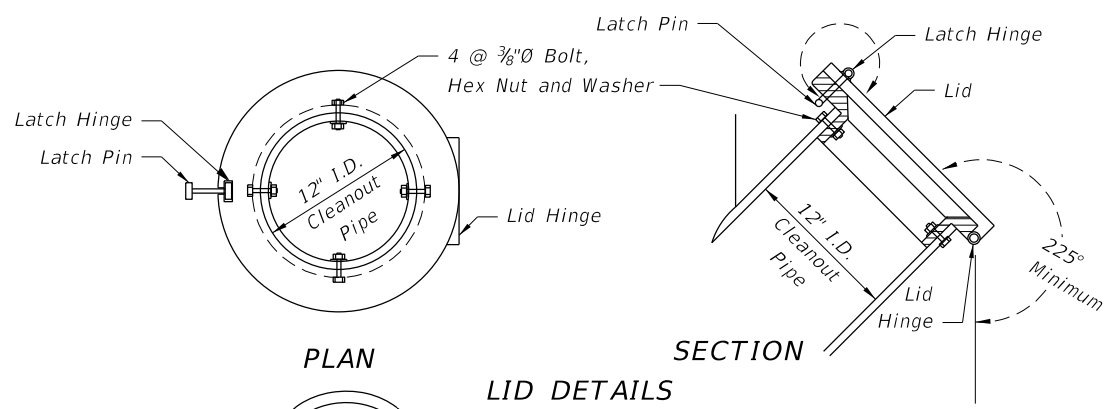

PLAN

SECTION

LID DETAILS

| TYPE I SKIMMER DIMENSION TABLE | | |
|--------------------------------|-----|-----|
| OUTLET PIPE | A | B |
| 18" | 12" | 42" |
| 24" | 15" | 48" |
| 30" | 18" | 54" |
| 36" | 21" | 60" |

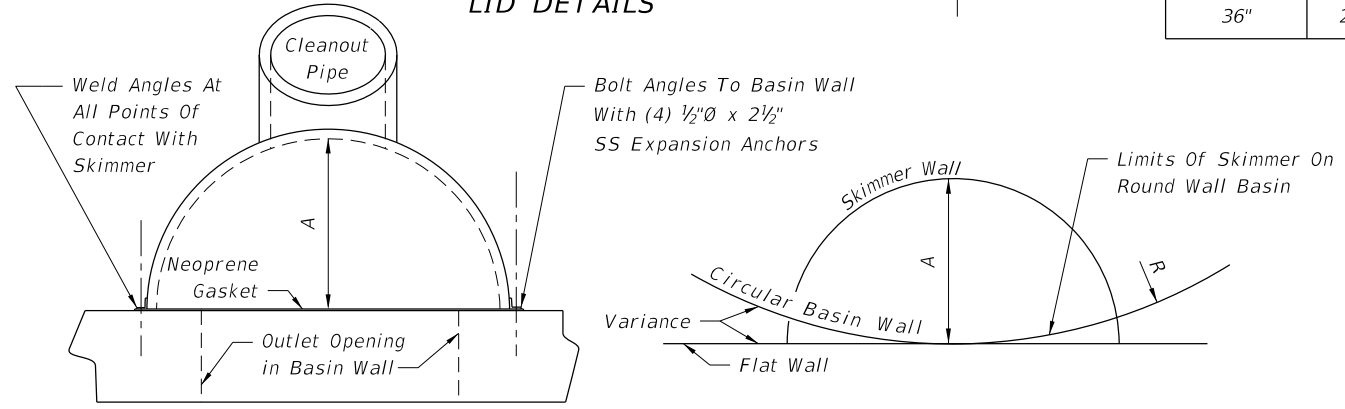

TOP VIEW

TOP VIEW SCHEMATIC

The backs of skimmers must conform to the shape of the basin walls on which they are mounted. Show, in the plans, the radii required for curved-back skimmers. Applies to both skimmer types.

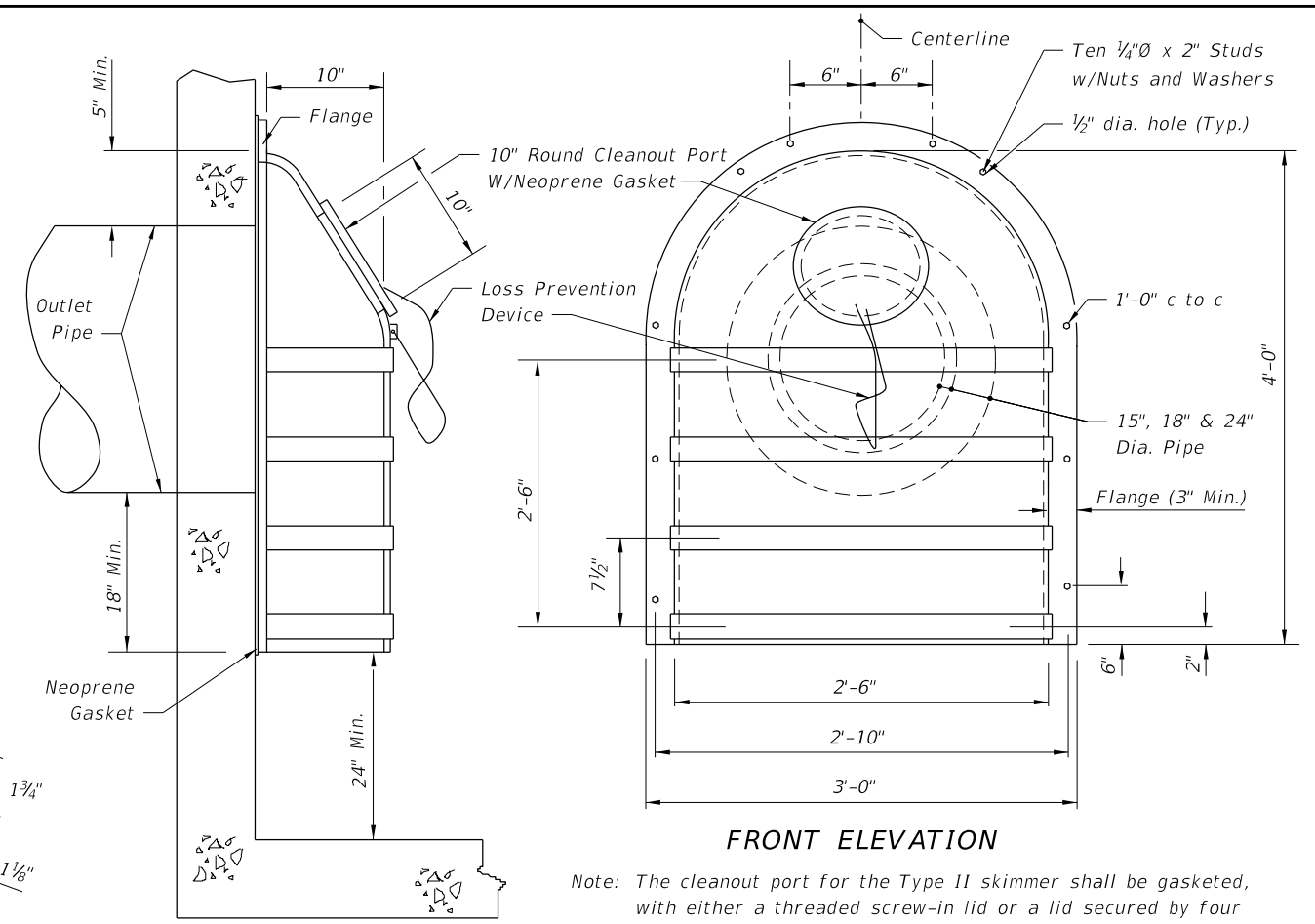

SIDE ELEVATION

FRONT ELEVATION

Note: The cleanout port for the Type II skimmer shall be gasketed, with either a threaded screw-in lid or a lid secured by four stainless steel quick-release latches.

TYPE II SKIMMER

GENERAL NOTES

- The Frenchdrain Skimmer is a hooded cover, mounted over an outlet in a catchbasin, that prevents oil and floating debris from exiting the basin. Use this skimmer in Frenchdrain Catchbasins and in other locations where there is a need to prevent oil, debris or other floating contaminants from exiting Catchbasins through outlet pipes.
- Place neoprene gasket material between the skimmer and the catchbasin at all points of contact. Trim the gasket neatly to extend 1/2 inch beyond the joint on all sides.
- Skimmer baffle, cleanout pipe and angles shall be primarily constructed of either galvanized steel, aluminum, polyvinyl chloride, polyethylene, fiberglass or acrylonitrile butadiene styrene. All steel components, other than stainless, shall be hot-dip galvanized.
- Mounting hardware, hinges and latches shall all be stainless steel. Loss prevention device shall be either stainless steel chain or riveted nylon strap.
- Material used in construction of skimmer bodies (baffles) and cleanout pipe shall comply with Standard Specification 943 for steel, 945 for aluminum or 948 for plastics.
- All costs for furnishing and installing a frenchdrain skimmer shall be included in the cost of the basin in which it is installed. Retrofit skimmers shall be paid for as 'modify existing structure'.
- Plastic Skimmers shall contain a minimum of 1.5% by weight of carbon black for UV protection.

DESIGN NOTES

- The contractor may submit an alternative design prefabricated Frenchdrain Skimmer for approval by the Engineer.
- Show, in the plans, the location of the basin and indicate the interior side(s) of the basin on which a skimmer will be installed.
- Type I Skimmer dimensions shall be based on the outlet pipe diameter as shown in the dimension table.
- Type II Skimmers are to be used only with outlet pipe diameters of 15", 18", and 24".

10/27/2017 6:44:33 AM