

VIEW A-A
(Shear key shown dashed)

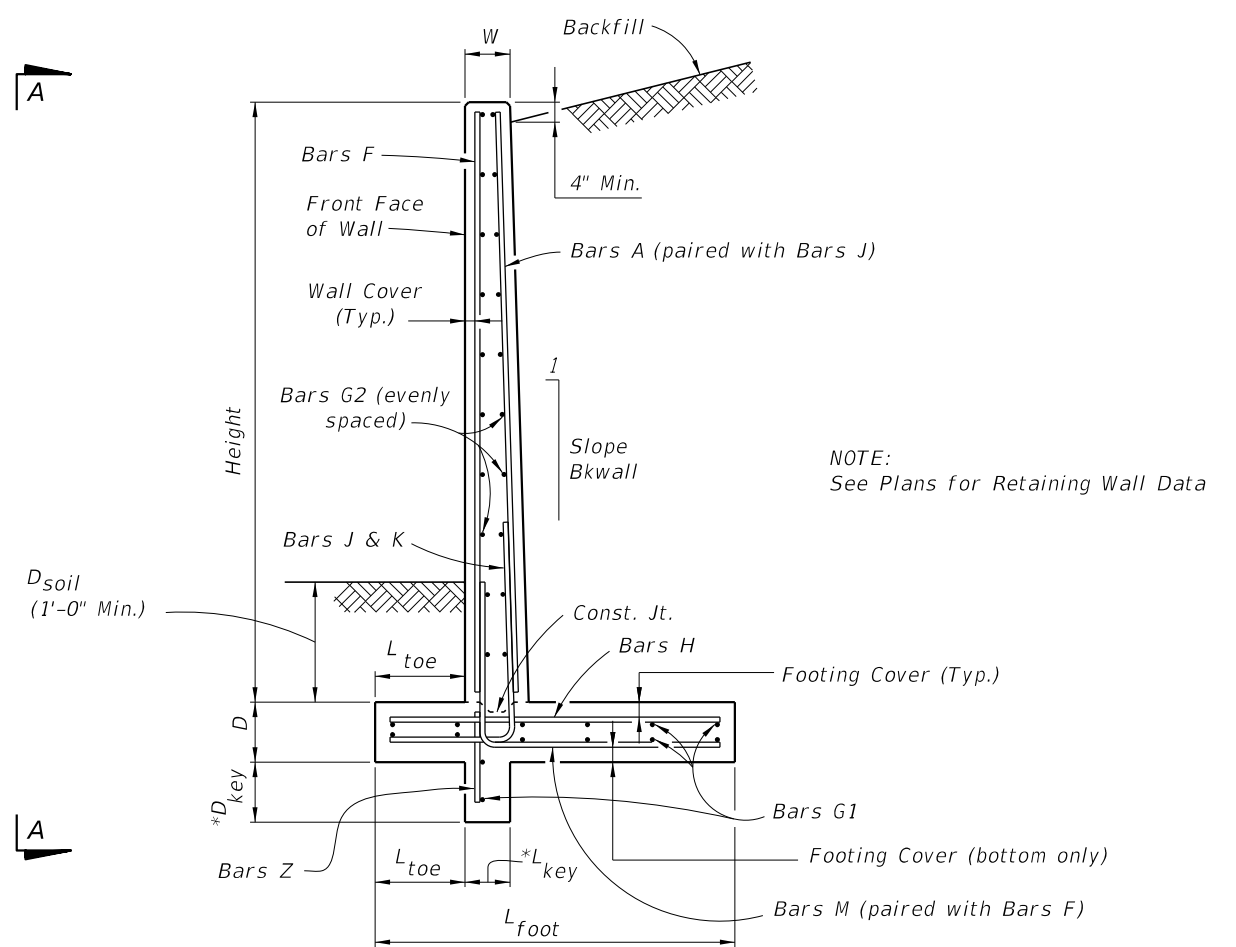

NOTE:
See Plans for Retaining Wall Data

* Shear Key is required only when specified in the Plans.

TYPICAL SECTION

NOTES

TRAFFIC RAILINGS OR PARAPETS:
If there is a Traffic Railing or Parapet on the wall, align Wall Joints with V-Grooves, and Wall Expansion Joints with Barrier Open Joints.

FOUNDATION: Prepare the soil below the footing in accordance with the requirements for spread footings in Specification Section 455.

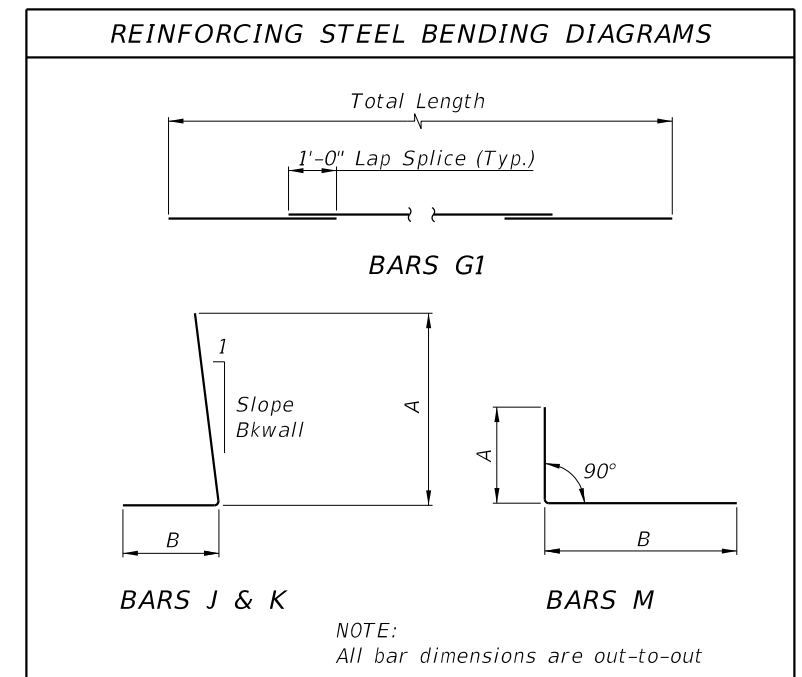

10/27/2017 7:54:17 AM

LAST REVISION 11/01/17	REVISION	DESCRIPTION:	 FY 2018-19 STANDARD PLANS	CANTILEVER RETAINING WALL (C-I-P)	INDEX 400-010	SHEET 1 of 2
---------------------------	----------	--------------	---	--	-------------------------	------------------------

**Wall joint spacing 25 ft. maximum and 5' minimum. At minimum, every fourth wall joint to be an expansion joint. See Plans for actual wall joint spacing and expansion joint location.

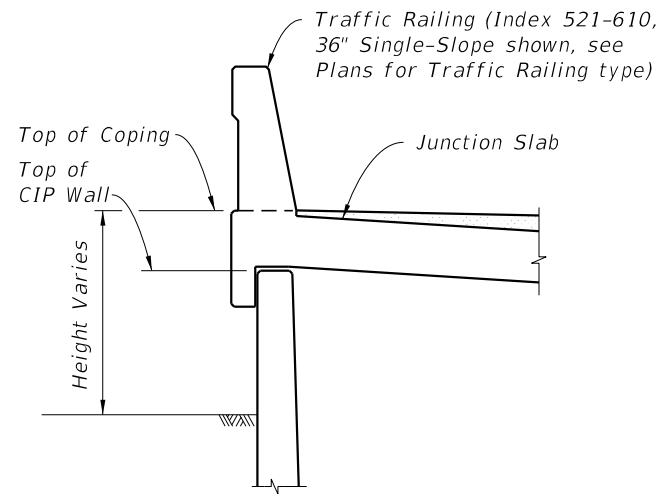
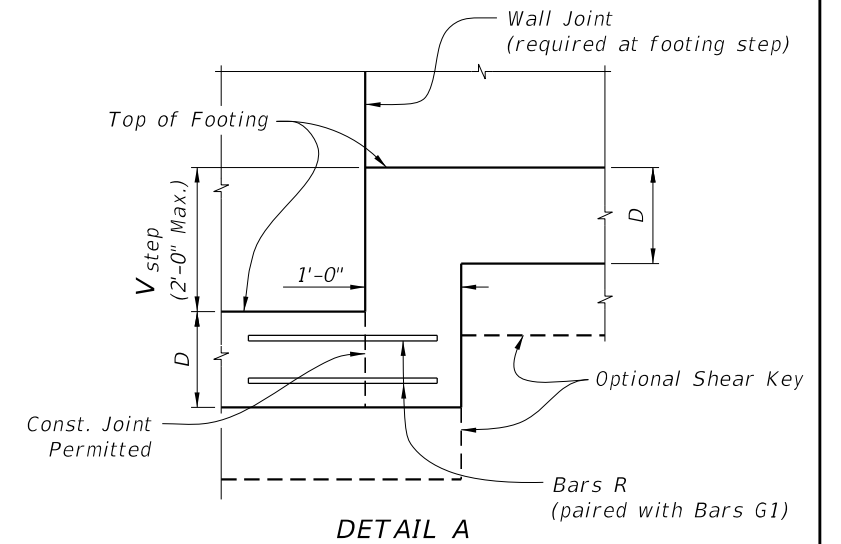
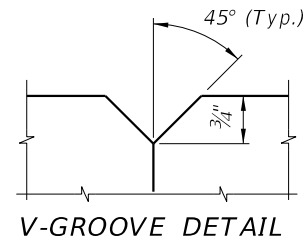
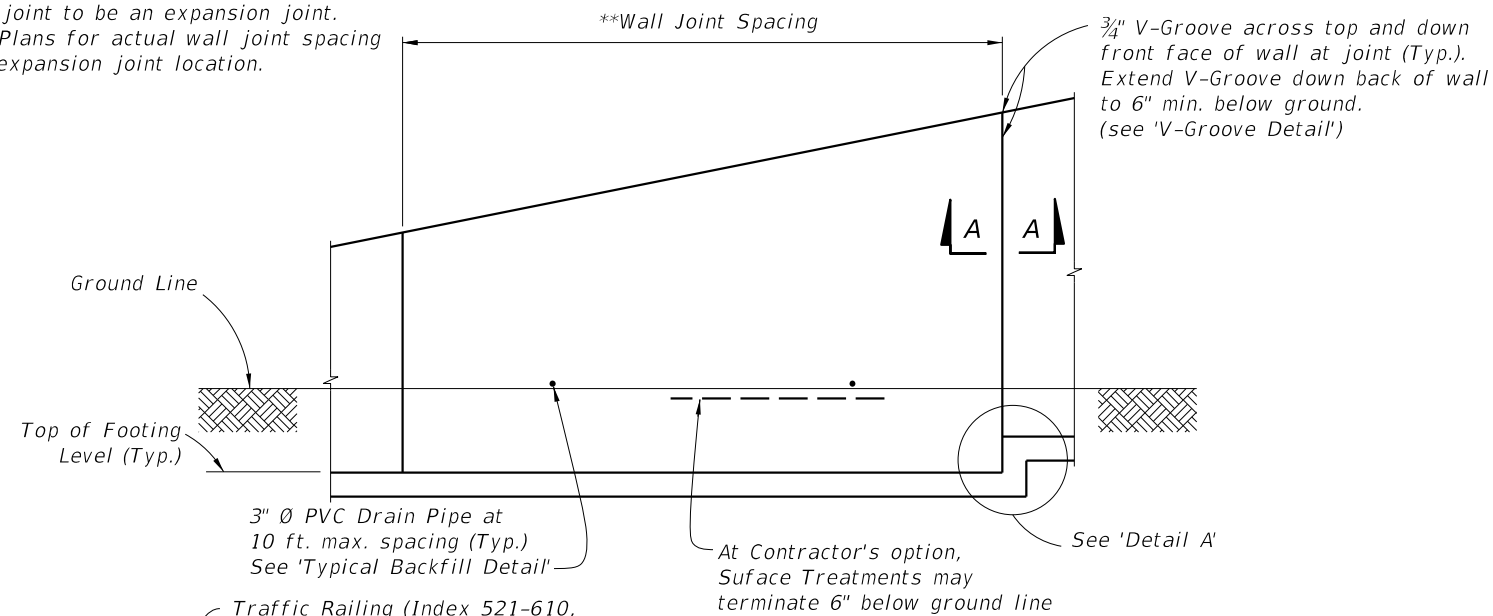

FRONT ELEVATION

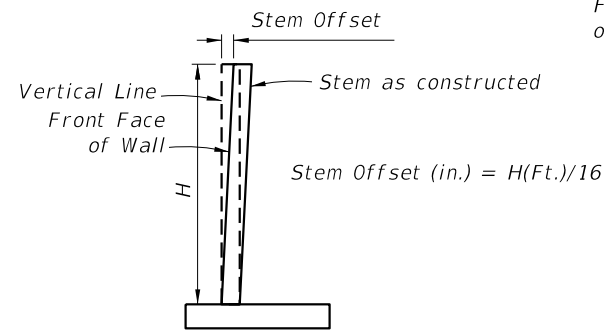

STEM OFFSET VALUES
(for H < 20 Ft.)

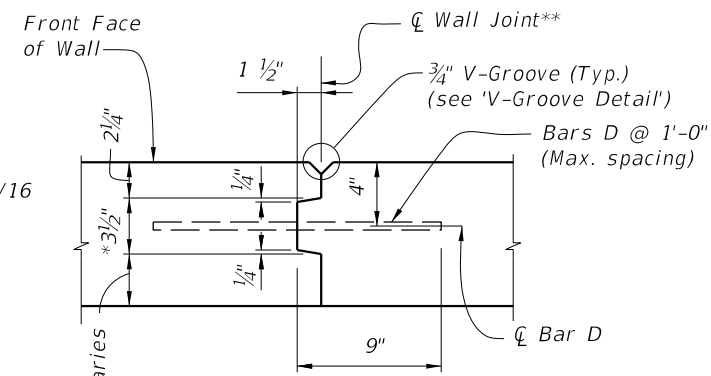

SECTION A-A WALL JOINT DETAIL

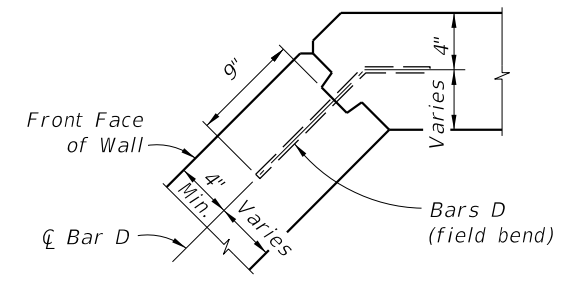

TYPICAL CORNER JOINT DETAIL

TRAFFIC RAILING/JUNCTION SLAB DETAIL
(36" Single-Slope shown, other Traffic Railings similar)

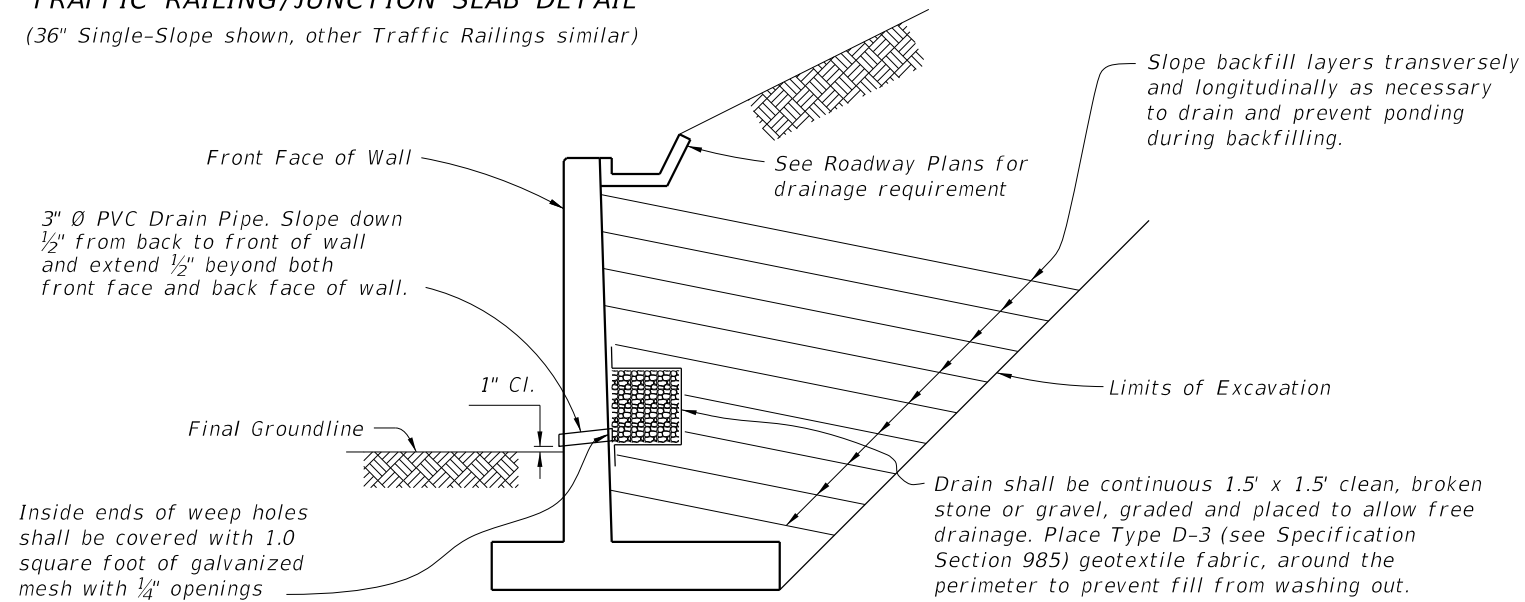

TYPICAL BACKFILL DETAIL

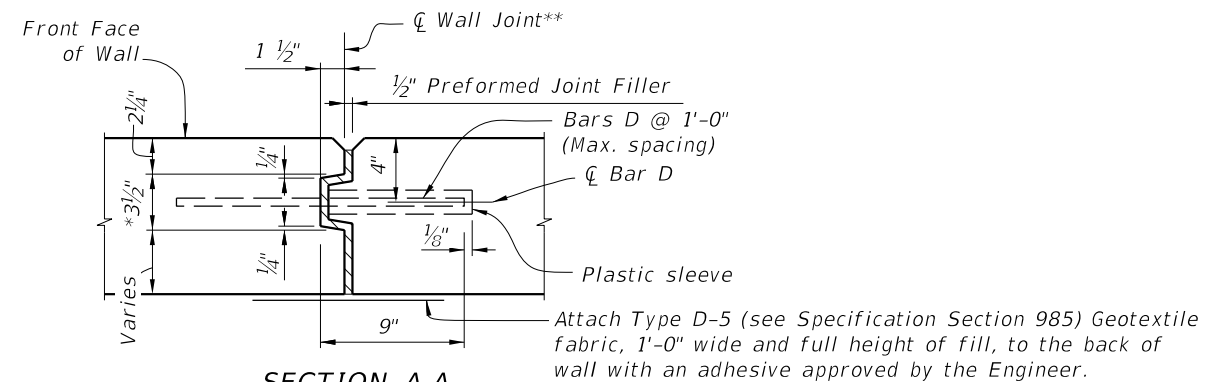

SECTION A-A EXPANSION JOINT DETAIL

* Key to stop at top of footing and 6" from top of wall. Joint across footing and top of wall to be a straight line.

** Stay-In-Place Plastic Preformed Bond Beakers are permitted to form joints.

10/27/2017 7:54:17 AM

LAST REVISION 11/01/17	DESCRIPTION:
---------------------------	--------------



FY 2018-19
STANDARD PLANS

CANTILEVER RETAINING WALL (C-I-P)

INDEX
400-010

SHEET
2 of 2