

\* If There is No Room in the Median for the PCMS, Then Locate it on the Outside of the Roadway only.

\*\* Install temporary Speeding Fines Doubled sign only if there is not an existing permanent "Speeding Fines Doubled Through Toll Plaza" sign or an existing "Speeding Fines Doubled When Workers Present" sign in place.

**DEDICATED LANE(S) IN CENTER**

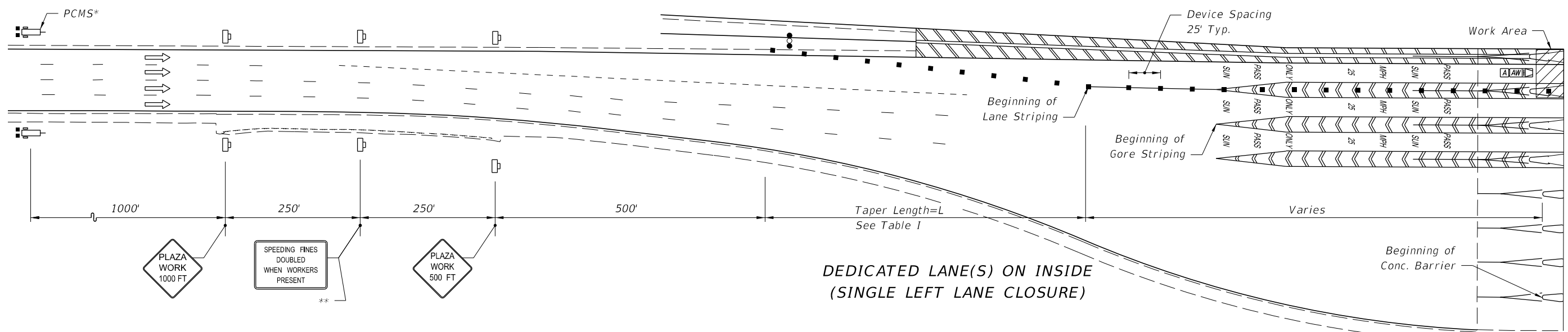

**DEDICATED LANE(S) ON INSIDE (SINGLE LEFT LANE CLOSURE)**

**SYMBOLS**

- Work Area
- Channelizing Device (See Index 102-600)
- Work Zone Sign
- Advance Warning Arrow Board
- Lane Identification + Direction of Traffic
- Advance Warning Vehicle Equipped with Advance Warning Arrow Board and Truck/Trailer Mounted Attenuator
- Portable Changeable (Variable) Message Sign

<b>PCMS DISPLAY A</b>	
MESSAGE 1: SUNPASS LANE(S) CLOSED	MESSAGE 2: USE CASH LANES
<b>PCMS DISPLAY B</b>	
MESSAGE 1: SUNPASS ONLY LANE(S)	MESSAGE 2: CLOSED AT PLAZA
<b>PCMS DISPLAY C</b>	
MESSAGE 1: SUNPASS ONLY LANE(S)	MESSAGE 2: KEEP LEFT/RIGHT

Dedicated Lane Location	Number of Dedicated Lanes	Number of Dedicated Lanes Closed	Taper Length (Feet)	PCMS Display
Center	1	1	200	A
	2	1	200	B
		2	350	A
Inside***	3	1	350	B
		2	350	A
	3	350	C	

\*\*\* See Index 102-667 Sheet 2 for Right or Center Inside Dedicated Lane Closed, or Two or More Inside Dedicated Lanes Closed Configurations.

**GENERAL NOTES**

1. This Plan is to be used at Mainline Plazas Only.
2. This Plan is for Lane Closures that exceed three hours.
3. Plaza canopies which have existing DMS signs on the canopies shall display the message "LANE CLOSED" for the duration of this closure.
4. A truck/trailer mounted attenuator is required.
5. Lane use control lights, signs, or signals over toll lanes shall be switched to the appropriate symbol, message, or correct color prior to the start of any lane closure. They should also be switched at project completion.
6. At least 48 hours prior to any closure, other than emergencies, the plaza manager shall be notified for security and staffing.

**DEDICATED LANES**

10/16/2017 8:18:16 AM

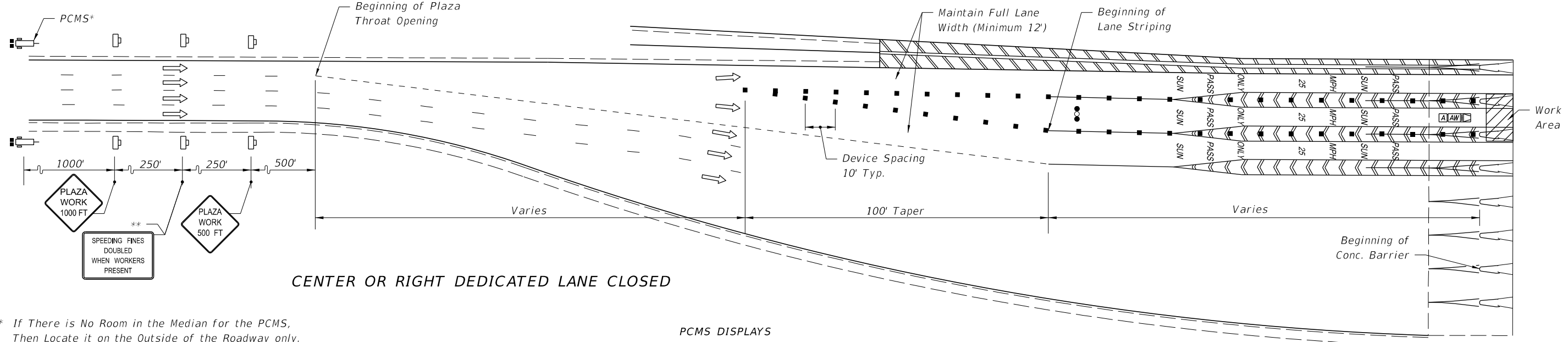

**CENTER OR RIGHT DEDICATED LANE CLOSED**

\* If There is No Room in the Median for the PCMS, Then Locate it on the Outside of the Roadway only.

\*\* Install temporary Speeding Fines Doubled sign only if there is not an existing permanent "Speeding Fines Doubled Through Toll Plaza" sign or an existing "Speeding Fines Doubled When Workers Present" sign in place.

**PCMS DISPLAYS**

MESSAGE 1: CENTER SUNPASS LANE      MESSAGE 2: CLOSED AT PLAZA      MESSAGE 1: SUNPASS ONLY LANE(S)      MESSAGE 2: KEEP LEFT

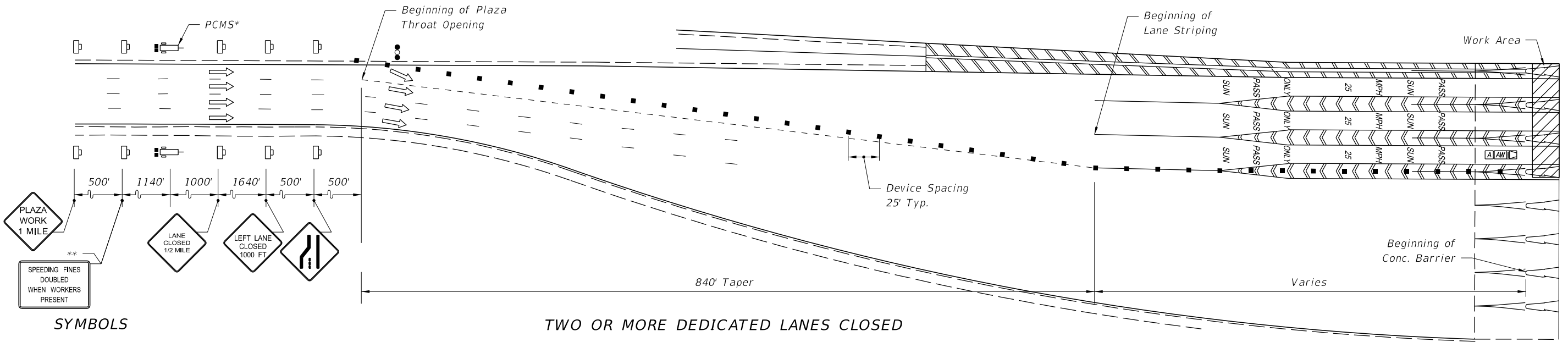

**TWO OR MORE DEDICATED LANES CLOSED**

**SYMBOLS**

- Work Area
- Channelizing Device (See Index 102-600)
- Work Zone Sign
- Advance Warning Arrow Board
- Lane Identification + Direction of Traffic
- Advance Warning Vehicle Equipped with Advance Warning Arrow Board and Truck/Trailer Mounted Attenuator
- Portable Changeable (Variable) Message Sign

**PCMS DISPLAY**  
 MESSAGE 1: SUNPASS LANES CLOSED      MESSAGE 2: USE CASH LANES

**GENERAL NOTES**

1. This Plan is to be used at Mainline Plazas Only.
2. This Plan is for Lane Closures that exceed three hours.
3. Plaza canopies which have existing DMS signs on the canopies shall display the message "LANE CLOSED" for the duration of this closure.
4. A truck/trailer mounted attenuator is required.
5. See Sheet 1 for Two or More Inside Dedicated Lanes Single Left Lane Closed Configuration.
6. Lane use control lights, signs, or signals over toll lanes shall be switched to the appropriate symbol, message, or correct color prior to the start of any lane closure. They should also be switched at project completion.
7. At least 48 hours prior to any closure, other than emergencies, the plaza manager shall be notified for security and staffing.

**INSIDE DEDICATED LANES**

10/16/2017 8:18:16 AM

LAST REVISION 11/01/17	REVISION	DESCRIPTION:		FY 2018-19 STANDARD PLANS	TOLL PLAZA TRAFFIC CONTROL STANDARDS	INDEX 102-667	SHEET 2 of 6
---------------------------	----------	--------------	--	------------------------------	--------------------------------------	------------------	-----------------

\* If there is no room in the median for the PCMS then locate it on the outside of the roadway only.

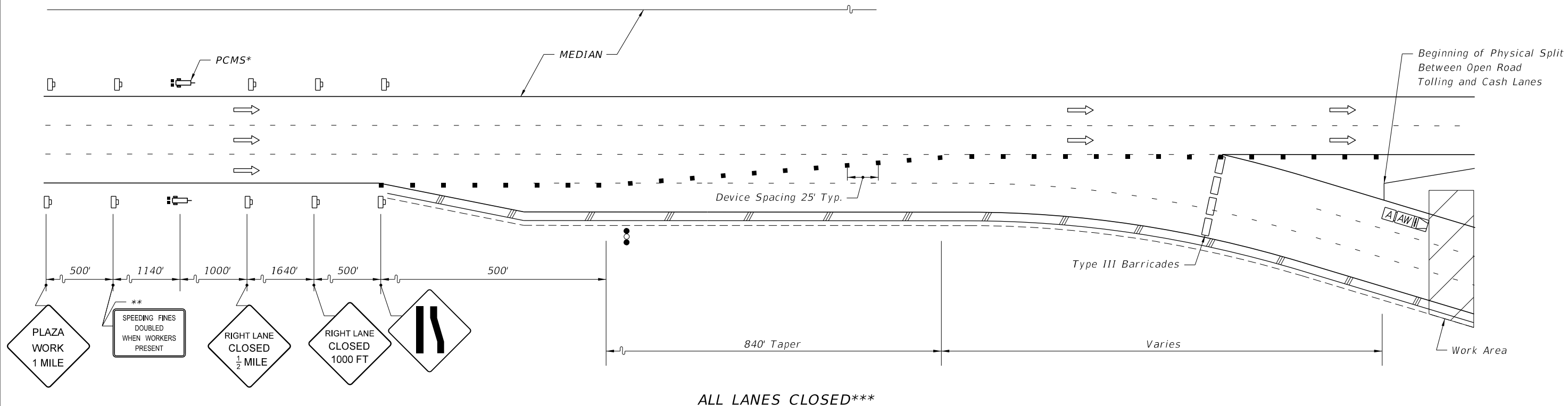

\*\* Install temporary Speeding Fines Doubled sign only if there is not an existing permanent "Speeding Fines Doubled Through Toll Plaza" sign or an existing "Speeding Fines Doubled When Workers Present" sign in place.

\*\*\* Inverted for Inside Open Road Tolling Lanes Configuration

**GENERAL NOTES**

1. This Plan is to be used at Mainline Plazas Only.
2. This Plan is for lane closures of any time length.
3. Plaza canopies which have existing DMS signs on the canopies shall display the message "LANE CLOSED" for the duration of this closure.
4. For planned lane closure, a portable changeable message sign shall be placed and shall display the message shown at a minimum of one week prior to closure. If planned lane closure is less than one week, place portable changeable message sign immediately using "prior to closure" messages.
5. A truck/trailer mounted attenuator is required.
6. Lane closure configurations applicable to 2 or 3 lane open road tolling plazas.
7. At least 48 hours prior to any closure, other than emergencies, the plaza manager shall be notified for security and staffing.

**SYMBOLS**

- Work Area
- Channelizing Device (See Index 102-600)
- Work Zone Sign
- Advance Warning Arrow Board
- Lane Identification + Direction of Traffic
- Advance Warning Vehicle Equipped with Advance Warning Arrow Board and Truck/Trailer Mounted Attenuator
- Portable Changeable (Variable) Message Sign
- Type III Barricades and "RAMP CLOSED" sign

PCMS DISPLAYS

PCMS DISPLAY PRIOR TO CLOSURE

MESSAGE 1: SUNPASS ONLY LANES      MESSAGE 2: CLOSED "DATE(S)"

PCMS DISPLAY DURING CLOSURE

MESSAGE 1: SUNPASS LANES CLOSED      MESSAGE 2: USE CASH LANES

**OUTSIDE OPEN ROAD TOLLING LANES**

10/16/2017 8:18:17 AM

LAST REVISION 11/01/17	REVISION	DESCRIPTION:	 FY 2018-19 STANDARD PLANS	TOLL PLAZA TRAFFIC CONTROL STANDARDS	INDEX 102-667	SHEET 3 of 6
---------------------------	----------	--------------	----------------------------------	--------------------------------------	------------------	-----------------

\* If there is no room in the median for the PCMS sign, then locate it on the outside of the roadway only.

\*\* Install temporary Speeding Fines Doubled sign only if there is not an existing permanent "Speeding Fines Doubled Through Toll Plaza" sign or an existing "Speeding Fines Doubled When Workers Present" sign in place.

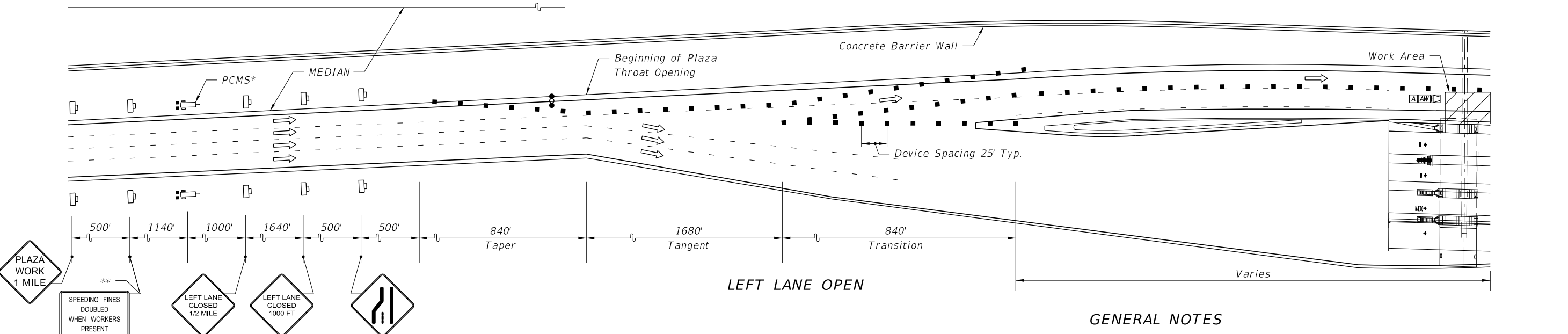
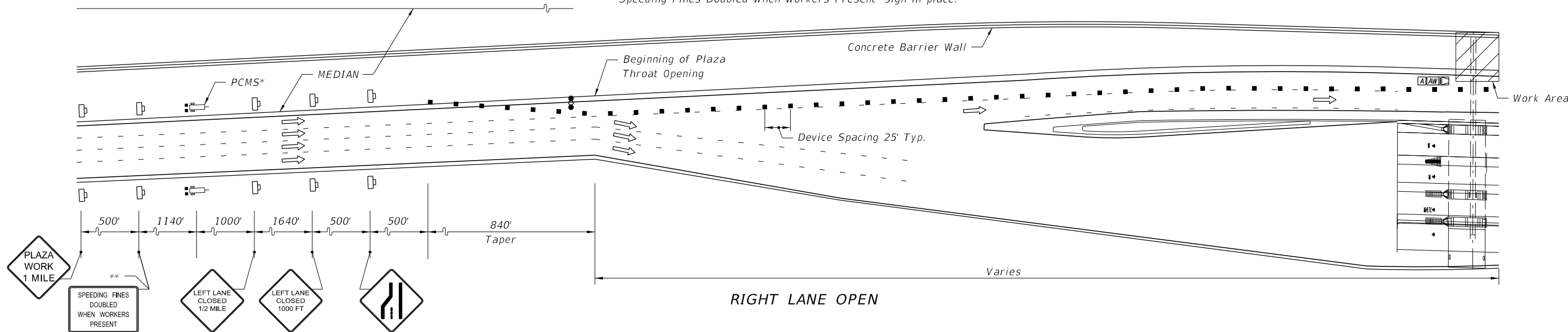

**SYMBOLS**

- Work Area
- Channelizing Device (See Index 102-600)
- Work Zone Sign
- Advance Warning Arrow Board
- Lane Identification + Direction of Traffic
- Advance Warning Vehicle Equipped with Advance Warning Arrow Board and Truck/Trailer Mounted Attenuator
- Portable Changeable (Variable) Message Sign

PCMS DISPLAYS

PCMS DISPLAY PRIOR TO CLOSURE

Message 1: ONE SUNPASS ONLY      Message 2: LANE OPEN "DATE(S)"

PCMS DISPLAY DURING CLOSURE

Message 1: SUNPASS ONLY LANE      Message 2: OPEN USE CAUTION

**GENERAL NOTES**

1. This Plan is to be used at Mainline Plazas only.
2. This Plan is for lane closures of any time length.
3. Plaza canopies which have existing DMS signs on the canopies shall display the message "LANE CLOSED" for the duration of this closure.
4. For planned lane closure, a portable changeable message sign shall be placed and shall display the messages shown at a minimum of one week prior to closure. If planned lane closure is less than one week, place portable changeable message sign immediately using "prior to closure" messages.
5. A truck/trailer mounted attenuator is required.
6. Lane closure configurations applicable to 2 or 3 lane open road tolling plazas.
7. At least 48 hours prior to any closure, other than emergencies, the plaza manager shall be notified for security and staffing.

**INSIDE OPEN ROAD TOLLING LANES**

10/16/2017 8:18:17 AM

LAST REVISION 11/01/17	REVISION	DESCRIPTION:		FY 2018-19 STANDARD PLANS	TOLL PLAZA TRAFFIC CONTROL STANDARDS	INDEX 102-667	SHEET 4 of 6
---------------------------	----------	--------------	--	------------------------------	--------------------------------------	------------------	-----------------

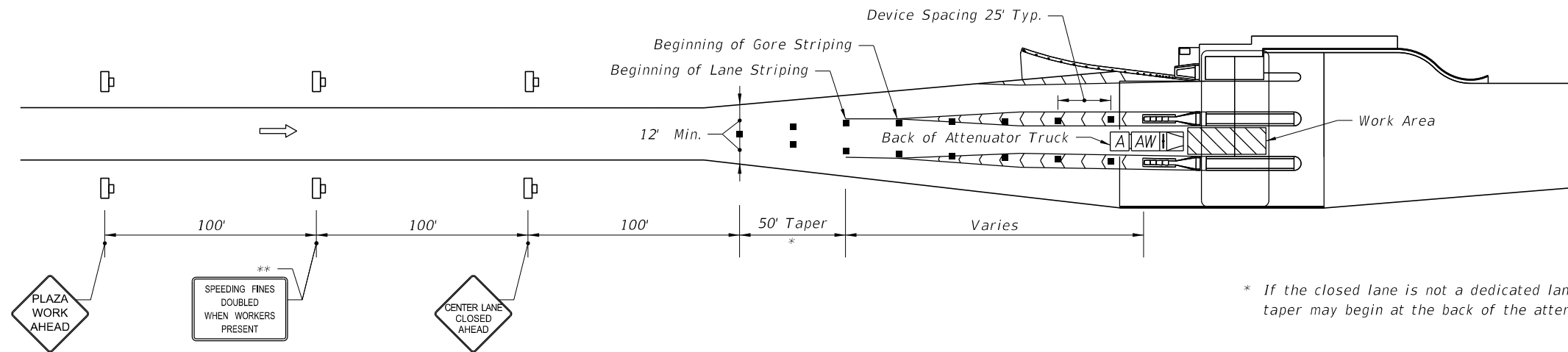

\* If the closed lane is not a dedicated lane, the 50' taper may begin at the back of the attenuator truck.

**EXHIBIT A**  
**DEDICATED, CASH, OR MIXED-USE LANES IN CENTER - ONE LANE CLOSED**  
 (This same plan can be used for any non-dedicated lane even if they are not in the center of the plaza)

\*\* Install temporary Speeding Fines Doubled sign only if there is not an existing permanent "Speeding Fines Doubled Through Toll Plaza" sign or an existing "Speeding Fines Doubled When Workers Present" sign in place.

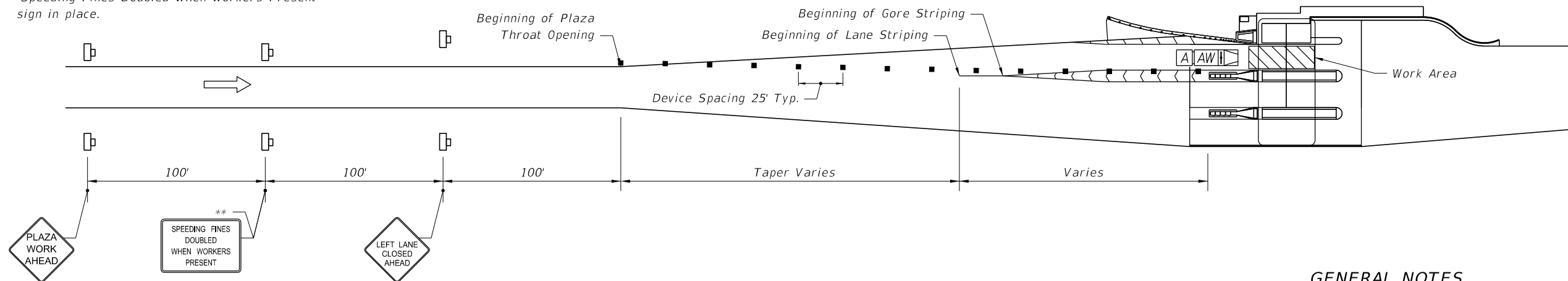

**EXHIBIT B**  
**DEDICATED LANE INSIDE OR OUTSIDE - ONE LANE CLOSED**  
 (Outside Lane Closure is a Mirror Image of this Exhibit)

**GENERAL NOTES**

1. This Plan is for lane closures that exceed three hours.
2. If the closed lane is a dedicated lane, Exhibit A shall be used at Ramp Plazas only. If the closed lane is a cash or mixed-use lane, Exhibit A may be used at Ramp or Mainline Plazas.
3. A truck/trailer mounted attenuator is required.
4. Exhibit B shall be used at Ramp Plazas only.
5. Lane use control lights, signs, or signals over toll lanes shall be switched to the appropriate symbol, message, or correct color prior to the start of any lane closure. They should also be switched at project completion.
6. At least 48 hours prior to any closure, other than emergencies, the plaza manager shall be notified for security and staffing.

**MAINLINE PLAZAS & RAMP PLAZAS**

- SYMBOLS**
- Work Area
  - Channelizing Device (See Index 102-600)
  - Work Zone Sign
  - Lane Identification + Direction of Traffic
  - Advance Warning Vehicle Equipped with Advance Warning Arrow Board and Truck/Trailer Mounted Attenuator

10/16/2017 8:18:18 AM

LAST REVISION 11/01/17	REVISION	DESCRIPTION:	 FY 2018-19 STANDARD PLANS	TOLL PLAZA TRAFFIC CONTROL STANDARDS	INDEX 102-667	SHEET 5 of 6
---------------------------	----------	--------------	----------------------------------	--------------------------------------	------------------	-----------------

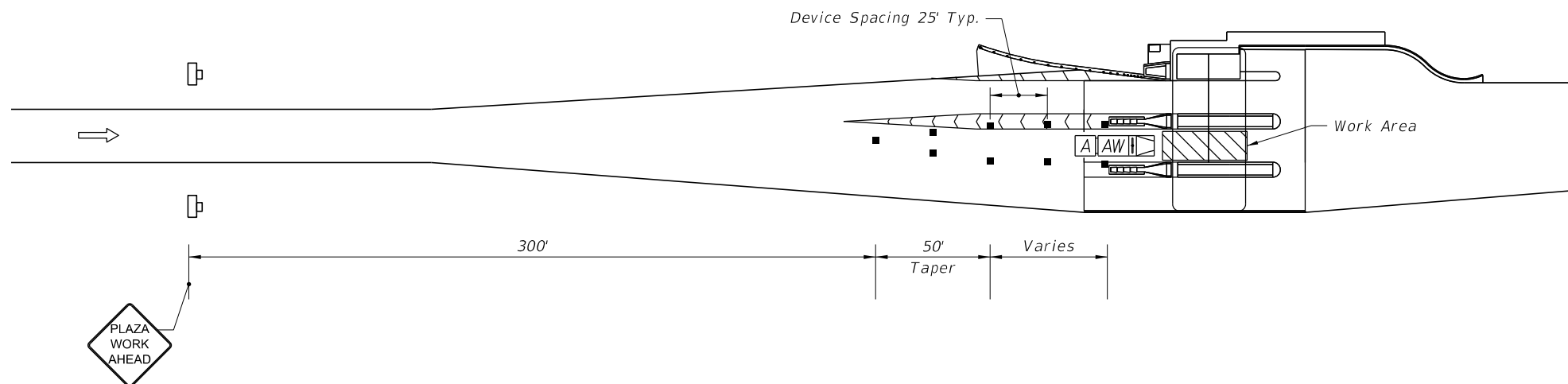



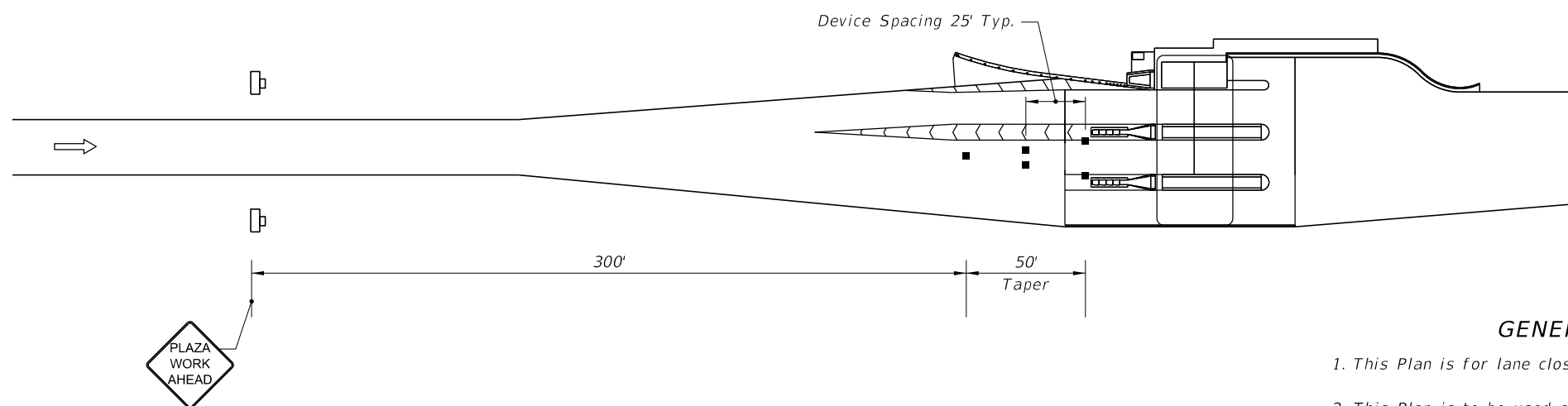

WORK DONE WITHIN TRAVEL LANE - ONE LANE CLOSED



WORK NOT DONE WITHIN TRAVEL LANE - ONE LANE CLOSED

**SYMBOLS**

-  Work Area
-  Channelizing Device (See Index 102-600)
-  Work Zone Sign
-  Lane Identification + Direction of Traffic
-  Advance Warning Vehicle Equipped with Advance Warning Arrow Board and Truck/Trailer Mounted Attenuator

**GENERAL NOTES**

1. This Plan is for lane closures that are three hours or less.
2. This Plan is to be used at Ramp or Mainline Plazas.
3. This plan can be used for any lane, with appropriate modifications, even if it is not in the center of the Plaza.
4. Lane use control lights, signs, or signals over toll lanes shall be switched to the appropriate symbol, message, or correct color prior to the start of any lane closure. They should also be switched at project completion.
5. At least 48 hours prior to any closure, other than emergencies, the plaza manager shall be notified for security and staffing.
6. A Truck/Trailer Mounted Attenuator is required for all aerial work operations (lift truck). For non-aerial operations, the Truck Mounted Attenuator or additional devices may be required by the Engineer based on the work being performed.

**SHORT-TERM CLOSURES**

10/16/2017 8:18:18 AM

LAST REVISION 11/01/17	REVISION	DESCRIPTION:	 <b>FY 2018-19 STANDARD PLANS</b>	<b>TOLL PLAZA TRAFFIC CONTROL STANDARDS</b>	INDEX <b>102-667</b>	SHEET <b>6 of 6</b>
---------------------------	----------	--------------	------------------------------------------------------------------------------------------------------------------------------	---------------------------------------------	-------------------------	------------------------