

Added: EXPRESS Pavement Message

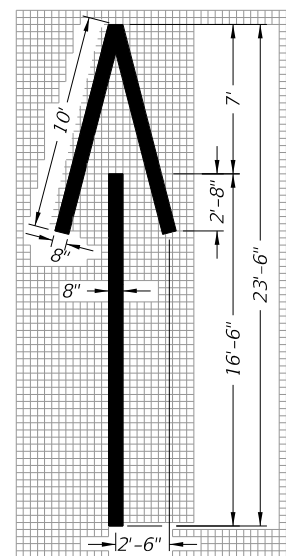

Wrong-Way Arrow  
24 S.F.

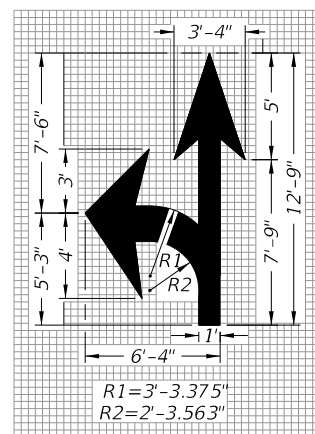

Turn and Through Lane-Use Arrow  
29 S.F.

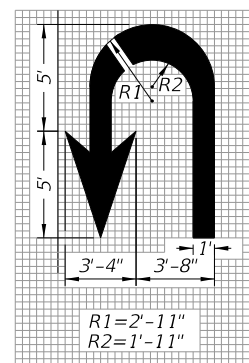

U Turn Lane-Use Arrow  
27 S.F.

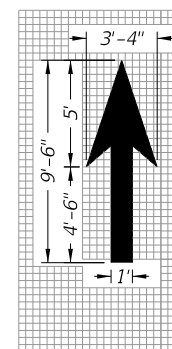

Through Lane-Use Arrow  
12 S.F.

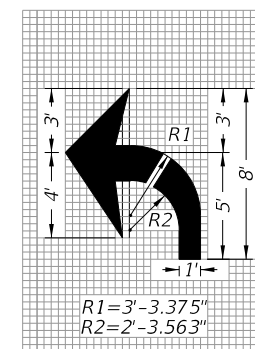

Turn Lane-Use Arrow (Left Turn Shown - Right Turn Similar by Opposite Hand)  
17 S.F.

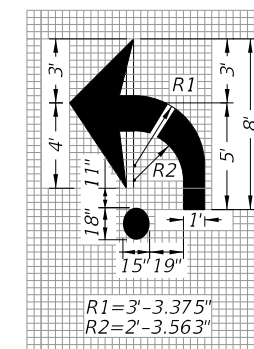

Roundabout Approach Arrow  
19 S.F.

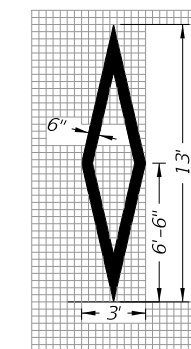

Preferential Lane Symbol  
11 S.F.

NOTES:

1. When an arrow and a pavement message are used together, locate the arrow 25' downstream from the pavement message. Measure the distance from the base of the arrow to the base of the pavement message.
2. Place stop message 25' back from the stop line.
3. Dimensions are within 1" ±.
4. All grids are 4" x 4".

PAVEMENT MESSAGE AND ARROW DETAILS

11/1/2017 2:33:11 PM

LAST REVISION 11/01/17	DESCRIPTION:		FY 2018-19 STANDARD PLANS	PAVEMENT MARKINGS	INDEX 711-001	SHEET 1 of 14
---------------------------	--------------	--	------------------------------	-------------------	------------------	------------------

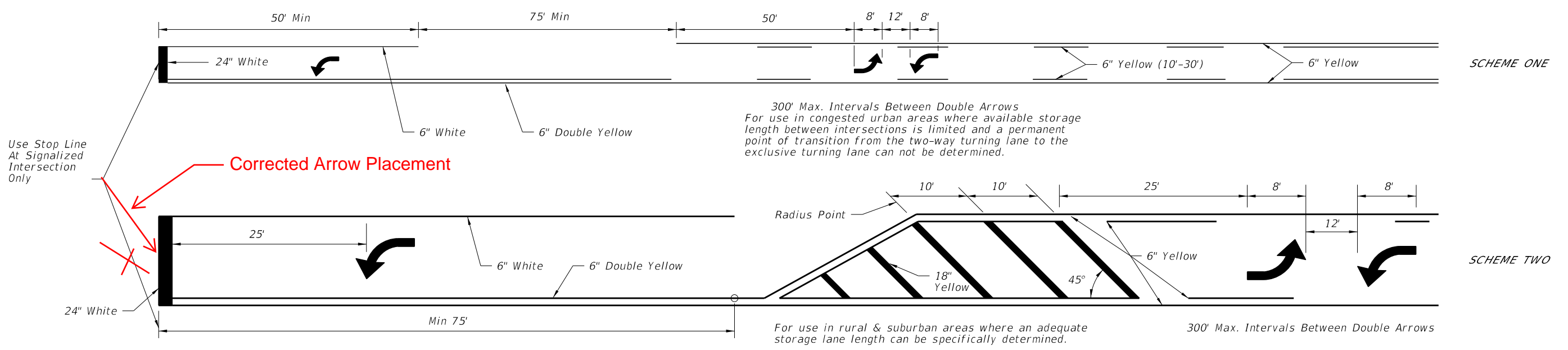

**TWO WAY LEFT TURN LANE**  
 (With Single Lane Left Turn Channelization)

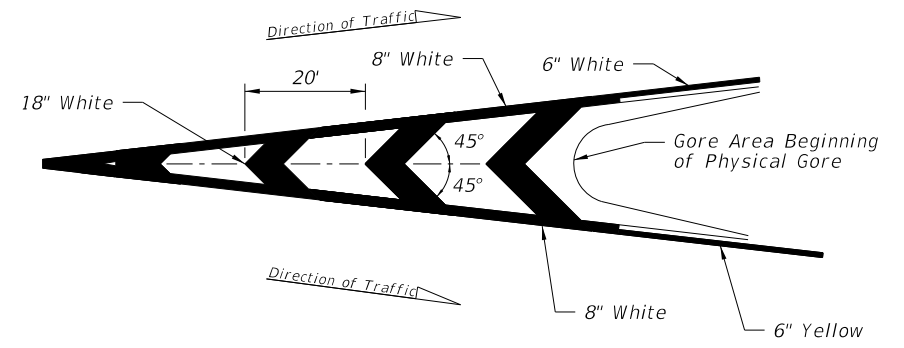
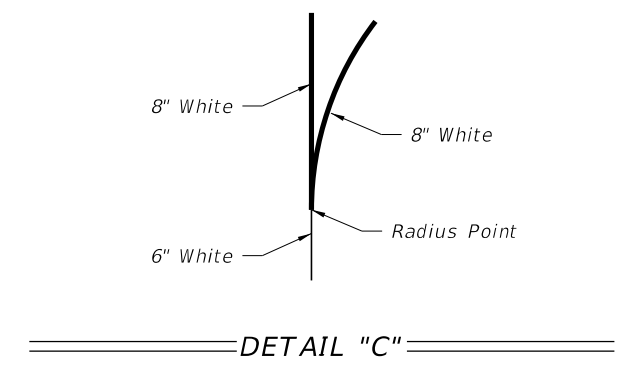
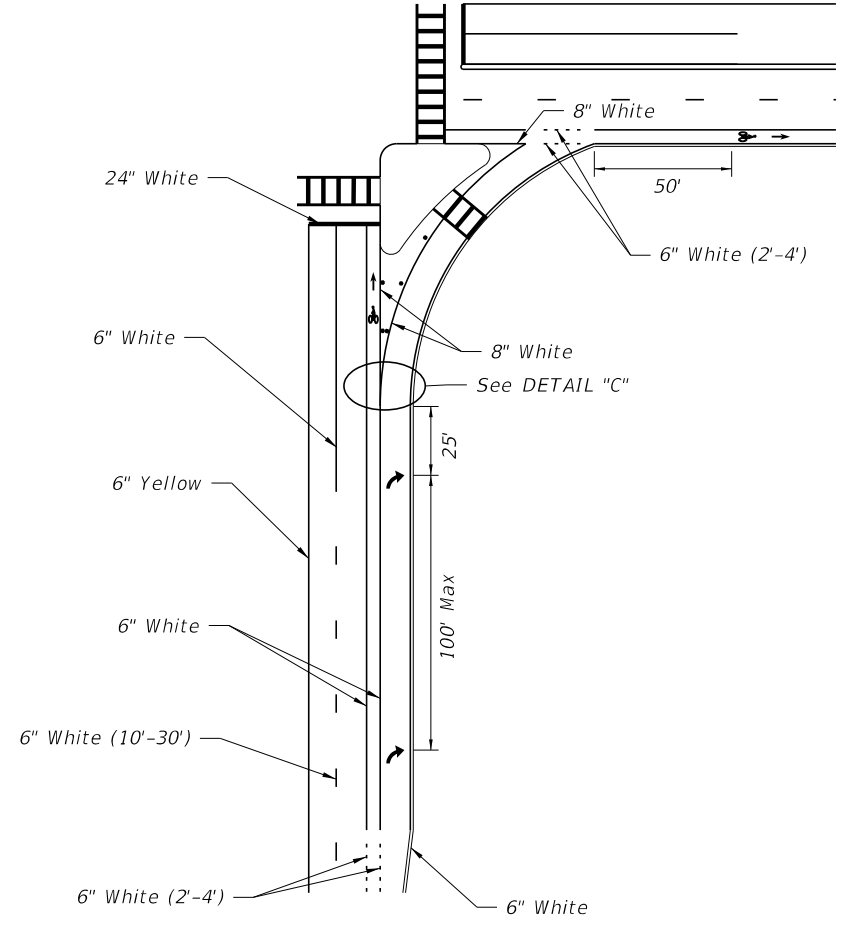
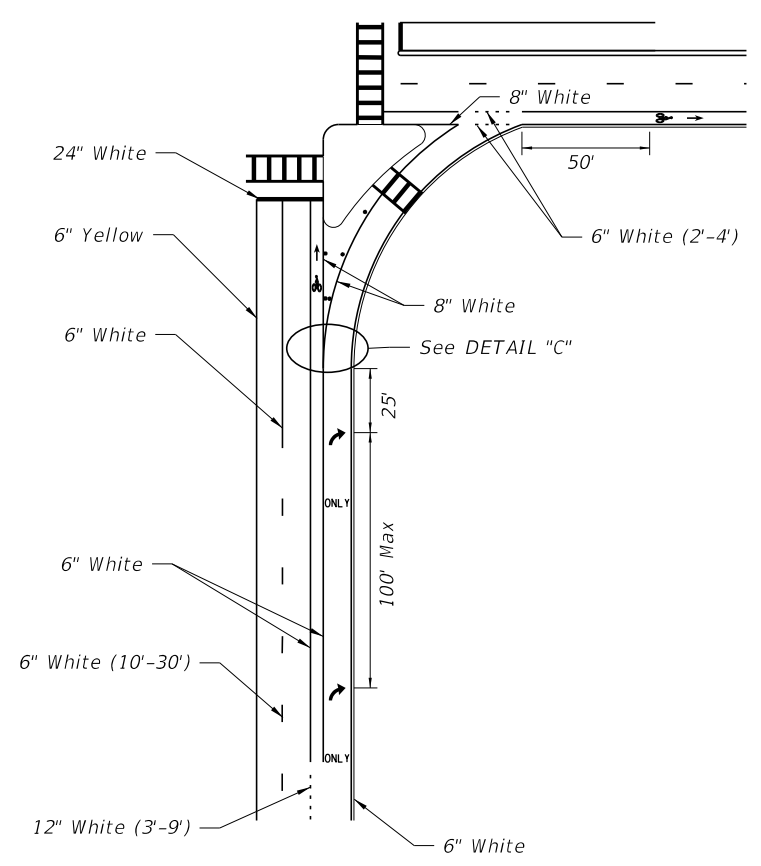

**RIGHT TURN LANE DROP AND ISLAND DETAILS**  
 LEFT TURN LANE DROP IS MIRROR IMAGE

**RIGHT TURN LANE AND ISLAND DETAILS**

**TRAFFIC CHANNELIZATION AT GORE**

11/13/2017 6:54:43 AM

LAST REVISION 11/01/17	DESCRIPTION:		FY 2018-19 STANDARD PLANS	PAVEMENT MARKINGS	INDEX	SHEET
					711-001	8 of 14