

**REVISION # 1.**  
**Florida Department of Transportation District 4**  
**Notice to Contractors- E4V18**

The Department of Transportation (Department) is soliciting contracting services for the Construction Manager / General Contractor (CM/GC) project identified below.

**Roosevelt Bridge Structural Monitoring Construction Manager / General Contractor (CM/GC)**

**RESPONSE REQUIREMENTS:**

**SELECTION PROCESS:** The Construction Manager/General Contractor (CM/GC) project is procured pursuant to Innovative Highway Projects, Florida Statutes, Section 337.025.

For this project, the Department will conduct a one-phase procurement process. The interested CM/GC firms must submit a Letter of Interest (LOI) and additional related documents for this project to the indicated requesting unit by the time and date indicated as the Response Deadline. It is the responsibility of the CM/GC firm to ensure that the complete LOI and related documents are timely received by the Department.

The LOI will be limited to five (5) 8½"x11" pages with a minimum font size of ten (10) and include 1" margins on all sides. In the LOI, please provide the name, address, phone number, and e-mail address for the CM/GC contact person. Resumes are to be submitted as noted below and are limited to one 8½"x11" page per person, with the same font and margin restrictions as the LOI. Resumes will not count toward the five (5) page LOI limitation. Please provide one (1) page resume for each of the following four (4) key staff positions and up to five (5) additional resumes of personnel who best highlight the experience and expertise of the CM/GC firm for this project, as applicable:

1. CM/GC Project Manager
2. Design Coordinator
3. Lead Instrumentation Technician
4. Testing and Monitoring Lead

A one (1) page 11"x17" organization chart shall be provided and is also excluded from the page count. The CM/GC firm must complete the Minimum Requirement Statement form included in the advertisement. Note: Resumes, Organizational Chart and the Minimum Requirement Statement are not considered in the five (5) page count/limitation for the LOI. Cover sheets, photos, charts, etc. or other documentation not specifically listed as exclusions will be considered in the page count limitation.

The Department will judge the relative ability of each submitting company/entity to perform the required services based on requirements included in this advertisement and the LOI. The following factors shall be considered by the Technical Review Committee in developing the final ranking recommendation:

1. Project Understanding and Approach
2. CM/GC and Project Relevant Experience
3. Relevant Experience of Key Personnel Proposed
4. Project Management Plan
5. Staffing Plan and Availability of Resources

The Technical Review Committee will develop a consensus recommendation of the CM/GC firm's final ranking for Selection Committee's review. The consensus recommendation will be transmitted

to the Selection Committee by the Procurement office. The Selection Committee will make the final decision to award based on the Technical Review Committee's recommendation and any other pertinent consideration factors, as determined by the Selection Committee.

Actual commitment and final execution of this contract is contingent upon an approved legislative budget and availability of funds.

The following minimum qualifications/requirements must be met for the successful responder. Failure to meet the requirements may be cause for the rejection of the LOI:

1. Performed an installation of Acoustic Emission systems on at least one multiple span structure over 500 ft with continuous monitoring. Describe and provide references.
2. Completed a project with remote or web-based monitoring and alarm trigger notification. Describe and provide references.
3. Proposed CM/GC Project Manager or Testing and Monitoring Lead shall have a minimum of 5 years' experience with acoustic monitoring and 10 years with structural monitoring. Describe and provide references. This criterion can be met by one person or the two individuals combined. Describe and provide references.
4. Shall have Acoustic Emission and Structural Monitoring equipment with a minimum of 5 years production of a commercially available product. Describe and provide references.

Response Requested:	Letter of Interest (LOI)
Maximum Number of LOI Pages:	5
Project Description:	Roosevelt Bridge Structural Monitoring Construction Manager / General Contractor (CM/GC)
Contract Number:	E4V18
Financial Project Number:	447687-1-H2-01
Project Manager:	Daniel Gonzalez, P.E.
Contract Lump Sum Amount	\$60,000 (Phase I, Lump Sum Pre-Construction Services)
Contract Duration:	60 days, <b>estimated</b> (Phase I, Pre-Construction Services); 120 days, estimated (Phase II, Construction Services); 5 years (Phase III, Operation/Monitoring/Maintenance Services)
Technical Review Committee:	Alberto Sardinas, William Potter, P.E., and Bruno Vasconcelos, P.E.
Selection Committee:	Gerry O'Reilly, P.E., Steve Braun, P.E, and Rosielyn Quiroz.
Request for Proposal (RFP)	Attached
OPEN BOOK COST ESTIMATING	Attached
Minimum Requirement Statement	Attached

Schedule - The times displayed are Eastern Standard time:

Schedule of Events	Date - Time
Advertisement Date	3/22/2021
Mandatory Project Meeting	3/29/2021(*) 11:00 AM - 12:00 PM (EDT) Please join my meeting from your computer, tablet or smartphone. <a href="https://global.gotomeeting.com/join/472012597">https://global.gotomeeting.com/join/472012597</a> You can also dial in using your phone. (For supported devices, tap a one-touch number below to join instantly.) United States: +1 (408) 650-3123 - One-touch: <a href="tel:+14086503123,472012597#">tel:+14086503123,472012597#</a> Access Code: 472-012-597
Response LOI Deadline Date/Time	4/12/2021 11:00 am
Technical Review Committee Ranking Meeting Date/Time	4/19/2021 9:00 am
Final Selection Committee Meeting Date/Time	4/26/2021 9:15 am

**LOI RESPONSE TO:**

Attn.: Margaret Simpkins

Submittals must be email to: [d4.designbuild@dot.state.fl.us](mailto:d4.designbuild@dot.state.fl.us)

Phone: (954) 777-4612

**COMMUNICATIONS BETWEEN CM/GC AND DEPARTMENT:** All communications between interested firms and the Department must be directed to the Department's Procurement Office. Questions must be submitted in writing to the email addresses below:

Margaret Simpkins, District Contracts Administrator

[d4.designbuild@dot.state.fl.us](mailto:d4.designbuild@dot.state.fl.us)

Phone: (954) 777-4612

Questions and responses will be shared with all CM/GCs.

**(\*) MANDATORY PROJECT MEETING:** For this project a mandatory Project Meeting is established. Letters of interest will be accepted only from the attendees of the meeting.

All bidders must be present and signed in prior to the start of the mandatory project meeting. Anyone not signed in at the commencement of the meeting will be considered late and will not be allowed to submit a Letter of Interest.

**AFFIRMATIVE ACTION (EQUAL EMPLOYMENT OPPORTUNITY):** The Florida Department of Transportation (hereinafter referred to as the "Department"), in accordance with Title VI of the Civil Rights Act of 1964, 42 USC 2000d to 2000d-4 and related authorities, Title 49, Code of Federal Regulations, U.S. Department of Transportation, Subtitle A, Office of the Secretary, Part 21, Nondiscrimination in Federally assisted programs of the U.S. Department of Transportation issued pursuant to such Act, hereby notifies all bidders that Bid Solicitation Notice Page 5 the Department will affirmatively insure that in any contract entered into pursuant to this advertisement, minority and disadvantaged business enterprises will be afforded the full opportunity to submit bids in response to this invitation and will not be discriminated against on the basis of race, color, national origin, or sex in consideration for an award. Further, it is the policy of the Department to not discriminate against bidders on the grounds of race, color, national origin, religion, sex, age, or disability/handicap in consideration for an award. A bidder must have an approved DBE Affirmative Action (DBE/AA) Plan prior to contract award. Please use the following link <https://www.fdot.gov/contracts/cpp-online-ordering/bidder-assist.shtm> Standard Specifications for Road and Bridge Construction and the Special Provisions for instructions for submission of a DBE/AA Plan. The DBE/AA Plan should be submitted for approval prior to the bidding.

**INSPECTOR GENERAL:** The contractor (CMGC) agrees to comply with section 20.055(5), Florida Statutes, and to incorporate in all subcontracts the obligation to comply with section 20.055(5), Florida Statutes.

**SCRUTINIZED COMPANIES:** A company that is on the Scrutinized Companies with Activities in Sudan List, is on the Scrutinized Companies with Activities in the Iran Petroleum Energy Sector List, or is engaged in business operations in Syria, may not bid on, submit a proposal for, or enter into a contract with an agency or local government entity for goods or services of \$1 million or more.

A company that is on the Scrutinized Companies that Boycott Israel List or is engaged in a boycott of Israel may not bid on, submit a proposal for, or enter into a contract with an agency or local government entity for goods or services.

**INSURANCE:** The successful bidder shall submit current general liability insurance and workers compensation insurance certificates for the duration of the contract in the dollar amounts and manner specified in the most current edition of the Department's Standard Specifications for Road and Bridge Construction. Insurance companies must be authorized to do business in the State of Florida. Proof of such insurance shall be filed with the District Contracts and Procurement Office before the contract can be executed. BE SURE THAT THE CONTRACT NUMBER IS ON EACH INSURANCE CERTIFICATE.

**DBE PARTICIPATION:** DBE Participation and Bidder Opportunity List for Prime Contractors should be reported in the Equal Opportunity Compliance (EOC) system. The EOC system is a web-based application for Prime Contractors, statewide, to report their Bidder Opportunity List, DBE Commitments, and DBE/MBE Subpayments. Please complete and submit the DBE Participation (i.e. DBE Commitments) and Bid Opportunity List in the EOC. More information regarding EOC can be referenced at: <http://www.fdot.gov/equalopportunity/eoc.shtm>

**DBE AND NON-DBE SMALL BUSINESS ASPIRATION GOAL:** It is the policy of FDOT to encourage the participation of small businesses and disadvantaged business enterprises ("DBE") in all facets of the business activities of FDOT, consistent with applicable laws and regulations. FDOT has established an aspiration goal of 10.65% DBE usage and an additional 3% non-DBE

Small Business usage for the subject Project. Firms proposing for this Project shall aspire to have 10.65% or more of the total contract costs performed by DBEs, and an additional three percent (3%) or more of the total contract costs performed by non-DBE small businesses. Although not a contract requirement, FDOT believes that the aforementioned aspiration goal can realistically be achieved based on current availability of DBEs and small businesses. FDOT further believes that the 13.65% overall goal can be achieved through race neutral means, using standard competitive procurement processes. Pursuant to the provisions of Section 339.0805, Florida Statutes, and Rule 14.78.005, Florida Administrative Code, FDOT has adopted rules to provide certified DBEs opportunities to participate in the business activities of FDOT as vendors, contractors, subcontractors, and consultants. FDOT has adopted the DBE definition set forth in Code 49 of Federal Regulations Section 26.5. The Department's DBE directory may be found [here](#). Firms agree to apply their best efforts to utilize qualified non-DBE small businesses as vendors, contractors, subcontractors, and consultants for the Project. Qualifications for small businesses may be found at the following website [this website](#). Firms will submit the [Aspiration Goal Form for "DBE" and "Non-DBE Small Business" Firms](#) at the Pre-Construction Conference.

**PROTEST RIGHTS:** Pursuant to Sections 120.57(3) and 337.11, Florida Statutes, and Rule Chapter 28-110, Florida Administrative Code, any person adversely affected by the agency decision or intended decision shall file with the agency both a notice of protest in writing and bond within 72 hours after the posting of the notice of decision or intended decision, or posting of the solicitation with respect to a protest of the terms, conditions, and specifications contained in a solicitation and will file a formal written protest within ten days after the filing of the notice of protest. The required notice of protest and bond, and formal written protest must each be timely filed with the **Florida Department of Transportation, Clerk of Agency Proceedings, 605 Suwannee St, Mail Station 58, Tallahassee FL 32399-0458**. Failure to file a notice of protest or formal written protest within the time prescribed in section 120.57(3), Florida Statutes, or failure to post the bond or other security required by law within the time allowed for filing a bond shall constitute a waiver of proceedings under Chapter 120 Florida Statutes.

**DEBARMENT/SUSPENSION:** All bids submitted to the Department shall include a statement that by signing and submitting this proposal, the bidder certifies that no principal (which includes officers, directors or executives) is presently debarred, suspended, proposed for debarment, declared ineligible or voluntarily excluded from participation in this transaction by any federal department or agency.

**MINIMUM WAGE:** The minimum wage for all hours worked in Florida is available at: <http://www.floridajobs.org>

**EXECUTION OF CONTRACT:** Pursuant to Subsections 3-6 and 3-7 of the Standard Specifications, the successful bidder shall execute the necessary contract documents and return the agreement along with a satisfactory Performance and Payment Bond within **five (5) Calendar days** of award, excluding Saturdays, Sundays, and state holidays, unless noted otherwise in the project

specifications. A 100% Payment and Performance Bond will be required for all projects unless noted otherwise in the project specifications. All work is to be done in accordance with the Plans, special Provisions of the State of Florida Department of Transportation.

Prior to execution of the contract with the Department, a corporation must show proof that it is authorized to do business in the State of Florida. Florida corporations should provide a copy of the certificate of Incorporation and foreign corporations should provide a copy of Certificate of Authority from the Florida Department of State.

Important Note: Actual commitment and final execution of the contract is contingent upon an approved legislative budget and funds availability.

### **Construction Manager / General Contractor Fixed-Markup Percentage**

The CM/GC construction services Markup for the Phase 2 Construction Services Limiting Amount Price and Phase 3 Operation/Monitoring/Maintenance Services consists of the CM/GC Contractor's profit and the portion of home office overhead (G&A: General and Administrative Costs) allocated to the project, where home office overhead (G&A) is defined as the cost of activities that are necessary to the overall operation of the CM/GC Contractor's business allocated to all of the CM/GC Contractor's ongoing projects, including insurance that is maintained by the CM/GC Contractor as a general cost of doing business. The CM/GC Markup will exclude all costs for any field indirect costs or direct costs of the Project.

This fee is represented as a fixed-markup percentage that is applied to the construction cost and becomes a part of the CM/GC Contractor's Lump Sum price proposal for the Phase 2 and Phase 3 construction of this project. The Department has established a fixed-markup percentage of **12.0 percent** for this project. By submitting an LOI response to this Notice, the Proposer implies acceptance of these terms. Any Proposal that places conditions to these terms or to FDOT will be considered non-responsive.

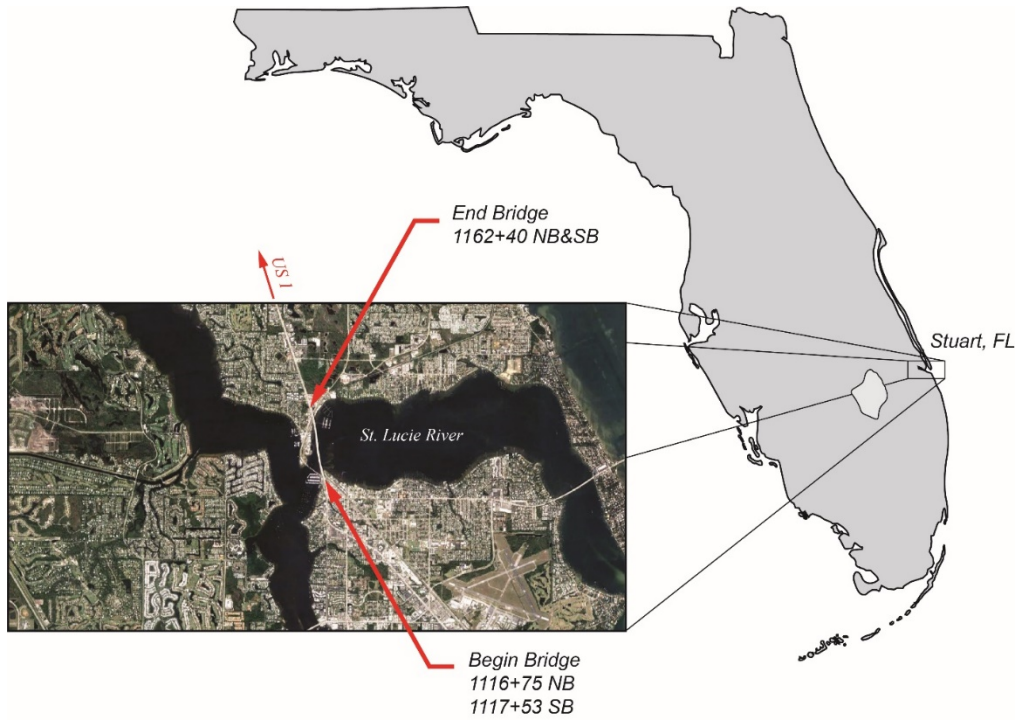

**Figure 1 – Project Location Map**

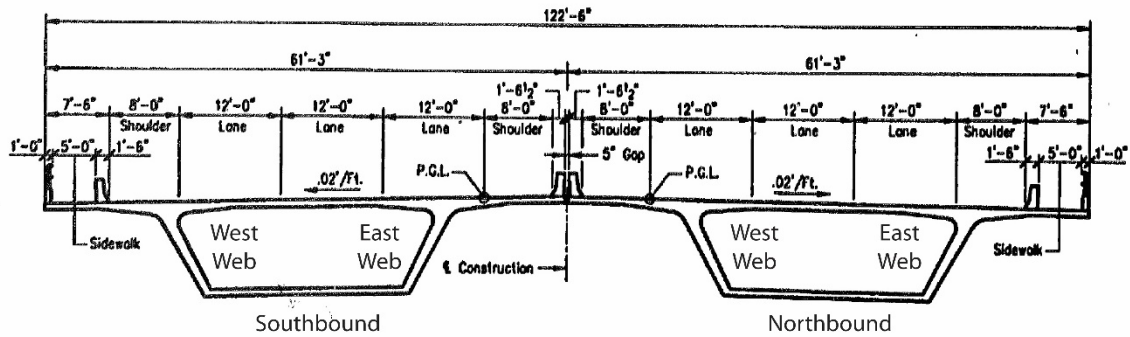

**Figure 2 – Typical Cross Section Looking Up-Station**

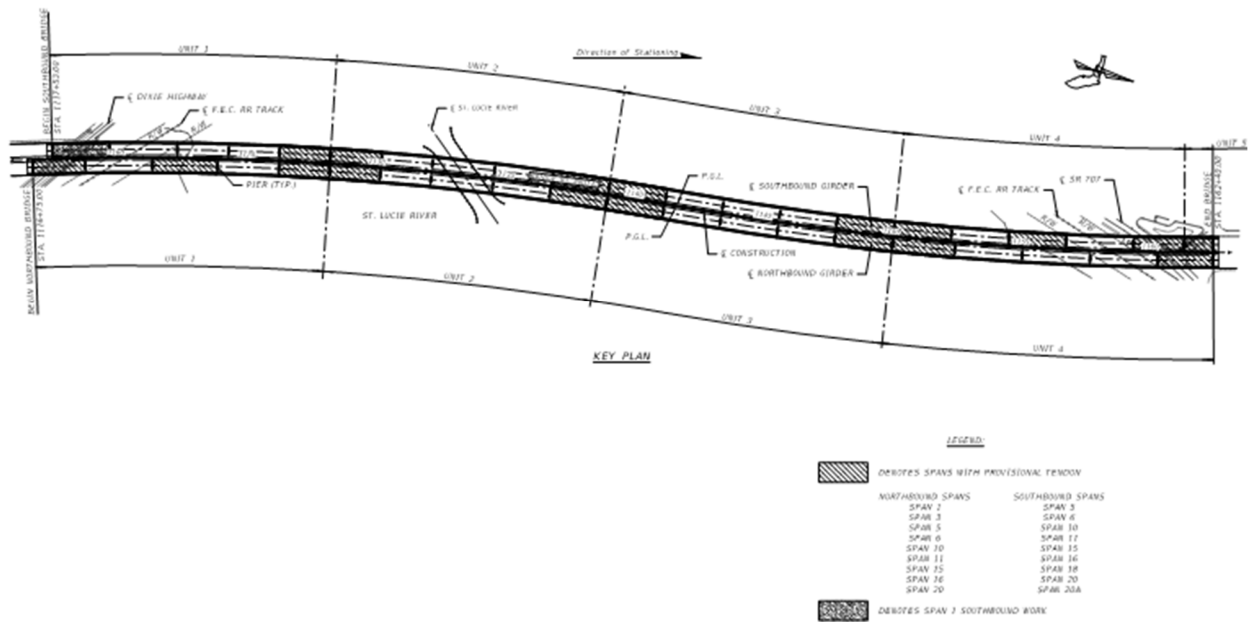

**Figure 3 – Bridge Plan**