

Chapter 4

Roadside Safety

4.1	Clear Zone	4-1
4.1.1	Clear Zone Concept	4-1
4.1.2	Clear Zone Criteria	4-2
4.1.3	Roadside Ditches	4-4
4.2	Hazard Standards	4-7
4.2.1	Canal Hazards	4-7
4.2.2	Drop-off Hazards	4-11
4.3	Roadside Barriers	4-13
4.3.1	Recommendations	4-13
4.3.2	Selection	4-14
4.3.3	End Treatments.....	4-14
4.3.4	Transitions	4-15
4.3.5	Placement	4-15
4.3.6	Upgrading Existing Barrier Systems	4-18
	4.3.6.1 Resetting Guardrail	4-19
4.3.7	Surface Finishes	4-20
4.4	Median Barriers.....	4-21
4.4.1	Recommendations	4-21
4.4.2	Selection	4-21
4.4.3	End Treatments.....	4-21
4.4.4	Median Barrier Surface Finishes	4-21
4.5	Permanent Crash Cushions	4-22
4.5.1	Recommendations.....	4-22
4.5.2	Selection	4-22

4.5.3	Design.....	4-23
4.6	Roadside Appurtenances	4-25
4.6.1	Sign Supports.....	4-25
4.6.2	Mailbox Supports	4-25
4.6.3	Other Appurtenances	4-25
4.6.4	Location Criteria	4-25
4.6.5	Bus Benches and Transit Shelters	4-25
4.7	Non-Standard Roadside Safety Devices	4-26

Tables

Table 4.3.1	Minimum Offset of Barriers (Measured from the face of the barrier)	4-16
-------------	--	------

Figures

Figure 4.1.2.1	Clear Zone Plan View.....	4-2
Figure 4.1.2.2	Clear Zone Cross Section	4-3
Figure 4.1.3.1	Roadside Ditch “V” Shape	4-5
Figure 4.1.3.2	Roadside Ditch “Trapezoidal” Shape.....	4-6
Figure 4.2.2	Drop-off Hazards in Urban Sections	4-11
Figure 4.3.1	Placement of Curb-Barrier Combinations	4-17

Exhibits

Exhibit 4-A	Minimum Standards for Canal Hazards (Rural and Urban Flush Shoulders)	4-9
Exhibit 4-B	Minimum Standards for Canal Hazards (Urban Curb or Curb and Gutter)	4-10

Chapter 4

Roadside Safety

4.1 Clear Zone

4.1.1 Clear Zone Concept

A roadside that is traversable and unobstructed by fixed objects will allow vehicles that leave the roadway to recover safely. The clear zone is the relatively flat unobstructed area that is to be provided for safe use by errant vehicles.

If natural or man-made hazards, including slopes steeper than 1:3, occur within the clear zone, the designer should attempt the following treatments, in order of priority:

Modification for Non-Conventional Projects:

Delete the sentence above and replace with the following:

If natural or man-made hazards, including slopes steeper than 1:3, occur within the clear zone, apply the following treatments, in order of priority:

1. Eliminate the hazard.
 - a. Remove the hazard.
 - b. Relocate the hazard outside the clear zone.
 - c. Make the hazard traversable or crashworthy.
2. Shield the hazard with a longitudinal barrier or crash cushion. This treatment is taken only when the barrier or crash cushion can be proven to have higher level of safety performance through RSAP or HSM analyses.
3. Leave the hazard unshielded. This treatment is taken only if a barrier or crash cushion is more hazardous than the hazard, if the likelihood of striking the hazard is very small or if the expense of treatment outweighs the benefits in terms of crash reduction as proven through the use of RSAP or HSM analyses.

If crash data or safety reports indicate that early treatment of the hazards will result in fewer or less severe crashes, designers shall implement those treatments as the first order of work, if feasible and practical.

4.1.2 Clear Zone Criteria

The clear zone must be wide enough so that the sum of all the recoverable terrain within is equal to or greater than the recoverable terrain value obtained in the appropriate **Table 2.11.11**, **Table 21.6** or **Table 25.4.14.1**. The process for determining the clear zone width is to extend the clear zone width as shown in **Figure 4.1.2.1** and **4.1.2.2** until the recoverable terrain is obtained. If non-recoverable terrain is encountered before obtaining the full amount of recoverable terrain, then the remaining amount must be provided beyond the non-recoverable terrain. Where right of way permits, the portion of recoverable terrain provided beyond the non-recoverable terrain must be a minimum of 10 feet. The clear zone is to be free of hazardous objects, hazardous terrain, and non-traversable terrain. Also, clear zones may be widened based on crash history.

Figure 4.1.2.1 Clear Zone Plan View

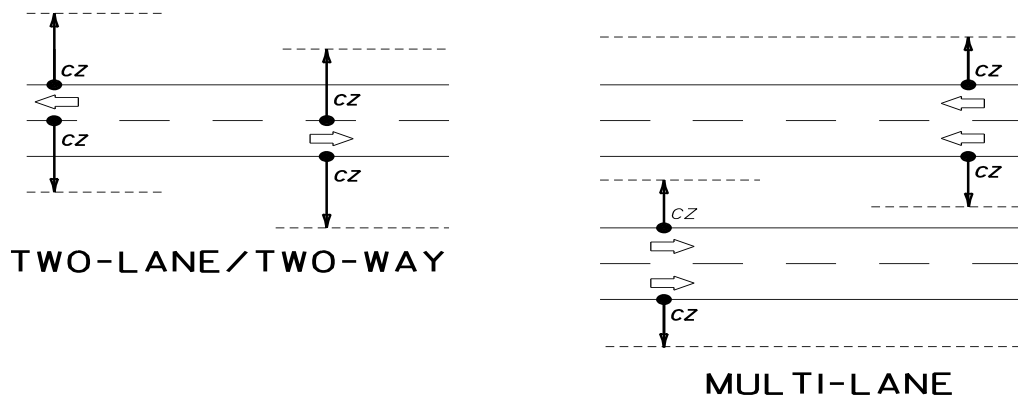
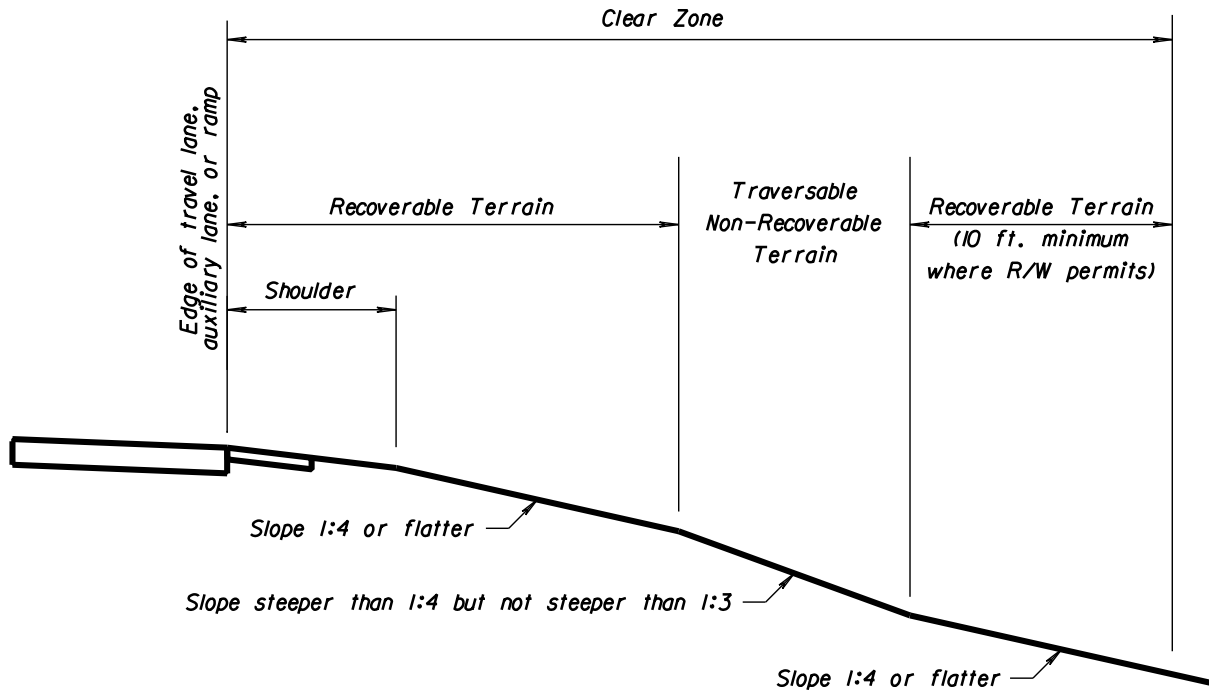

Figure 4.1.2.2 Clear Zone Cross Section



Note: See **Chapter 2, Table 2.4.1** for new construction slope criteria.
See **Chapter 25, Section 25.4.9** for RRR slope criteria.

Roadside Terrain includes all surfaces along the roadway other than Travel Lanes, Auxiliary Lanes, and Ramps. For the purpose of establishing Clear Zones, Roadside Terrain is defined as recoverable, non-recoverable, non-traversable, and hazardous as follows:

1. Traversable when the slope is 1:3 or flatter.
2. Recoverable when it is safely traversable and on a slope that is 1:4 or flatter.
3. Non-recoverable when it is safely traversable and on a slope that is steeper than 1:4 but not steeper than 1:3.
4. Traversable Non-recoverable when it is safely traversable and on a slope that is steeper than 1:4 but not steeper than 1:3.
5. Non-traversable when it is not safely traversable or on a slope that is steeper than 1:3.
6. Hazardous when a slope is steeper than 1:3 and deeper than 6 feet.

4.1.3 Roadside Ditches

Roadside ditches within the clear zone shall conform to the acceptable channel cross section criteria as shown in either **Figure 4.1.3.1** or **Figure 4.1.3.2**, as applicable. These roadside ditch configurations are considered traversable as shown in the **AASHTO Roadside Design Guide**. See the **AASHTO Roadside Design Guide** for further information. Ditch bottom widths shall be in accordance with the **Drainage Manual, Chapter 2**. Use of V-bottom ditches require approval from the District Drainage Engineer and shall be in conformance with **Figure 4.1.3.1**. Further guidance on Roadside Ditches can be found on the State Roadway Design webpage:

<http://www.dot.state.fl.us/rddesign/Drainage/Manualsandhandbooks.shtm>

Figure 4.1.3.1 Roadside Ditch “V” Shape

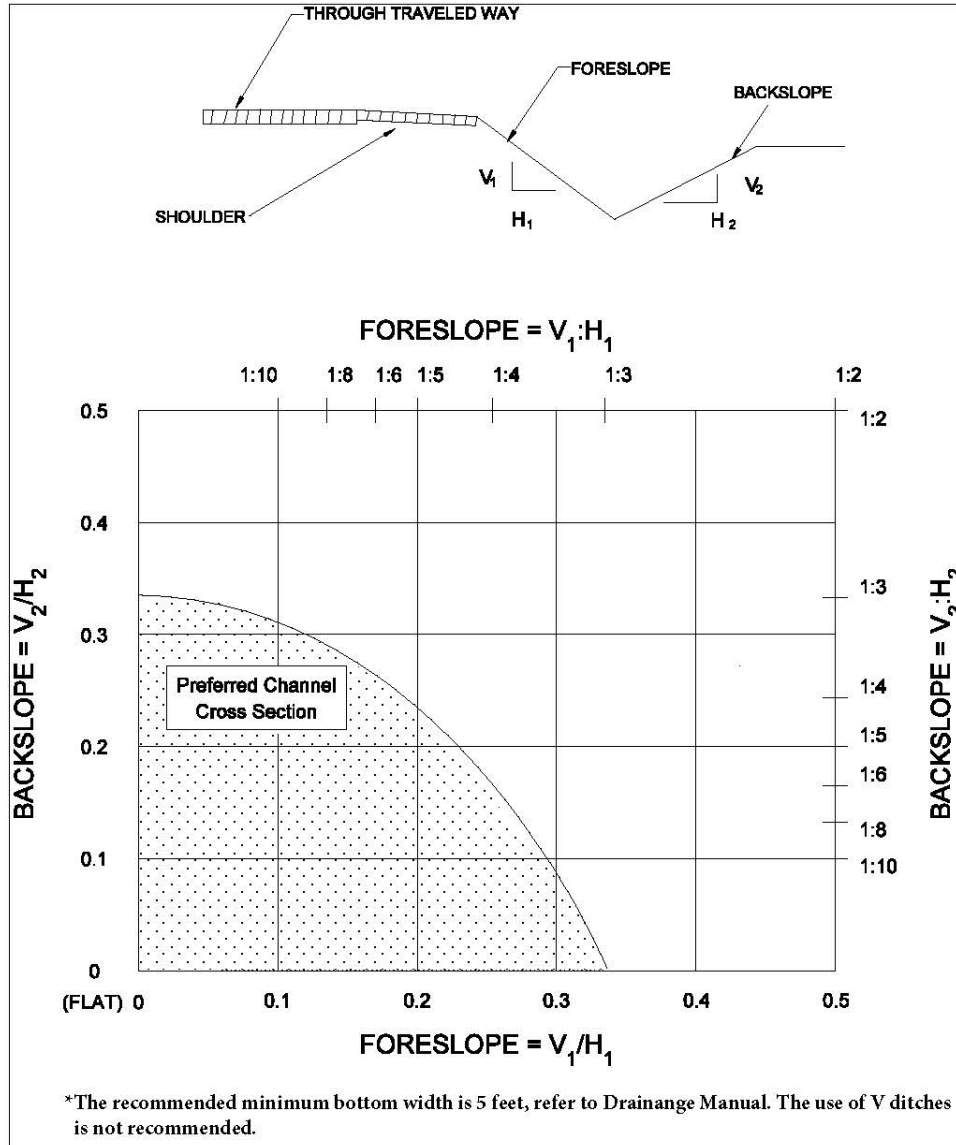

(Ref: *Figure 3-6 – 2011 AASHTO Roadside Design Guide*)

Figure 4.1.3.2 Roadside Ditch “Trapezoidal” Shape

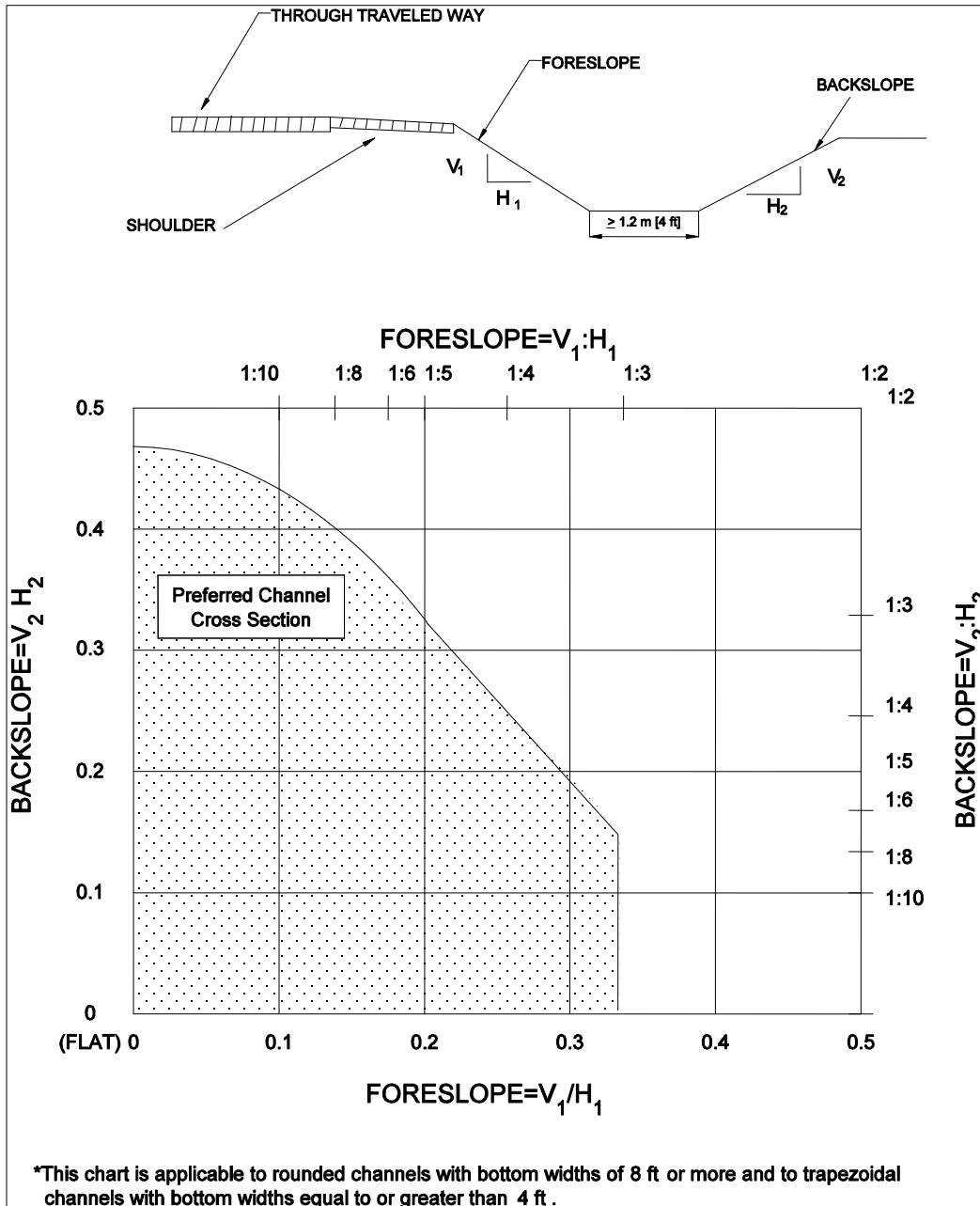

(Ref: *Figure 3-7 – 2011 AASHTO Roadside Design Guide*)

4.2 Hazard Standards

4.2.1 Canal Hazards

A canal is defined as an open ditch parallel to the roadway for a minimum distance of 1000 ft. and with a seasonal water depth in excess of 3 ft. for extended periods of time (24 hours or more).

Special lateral offset requirements apply to canal hazards that exceed standard clear zone distances. For rural and urban flush shoulder highways, the distance from the outside edge of the through travel lane or ramp to the top of the canal side slope nearest the road will be no less than 60 ft. for highways with design speeds of 50 mph or greater. For highways and ramps with design speeds less than 50 mph, this minimum distance shall not be less than 50 ft. for rural and urban flush shoulder highways or 40 ft. for urban curb or curb and gutter highways. When new canal or roadway alignment is required, distances greater than those above should be provided, if possible, to accommodate possible future improvements to the roadway (widening, etc.).

On fill sections, a flat berm (maximum 1:10 slope) of width no less than 20 ft. will be provided between the toe of the roadway front slope and the top of the canal side slope nearest the roadway. This minimum berm width applies to all types of highways, both rural and urban construction. (See **Exhibits 4-A & 4-B.**)

When the slope between the roadway and the "extended period of time" water surface is 1:6 or flatter, the minimum distance can be measured from the edge of the through lane or ramp to the "extended period of time" water surface and a berm is not required.

In sections with ditch cuts, 20 ft. will be provided between the toe of the front slope and the top of the canal.

When it is not practical to meet the above minimum criteria, the canal hazard shall be shielded with guardrail, high tension cable barrier, or other approved roadside barrier. Barriers shall be located as far from the travel way as practical. When shielding canal hazards located outside standard clear zone distances, guardrail shall be located 5 feet from the canal front slope and high tension cable barrier shall be located 15 feet from the canal front slope. These barrier location restrictions do not apply to cases where the barrier also serves to shield hazardous side slope conditions or other linear hazard located within the standard clear zone distance. Where compliance with these barrier location restrictions is not practical due to site conditions, a benefit cost analysis shall

be conducted to establish whether a barrier located closer to the travel way will result in a reduction in crash costs. In instances where the installation of a barrier results in an increase in crash costs, it may be appropriate to leave the canal hazard unshielded.

Exhibit 4-A Minimum Standards for Canal Hazards (Rural and Urban Flush Shoulders)

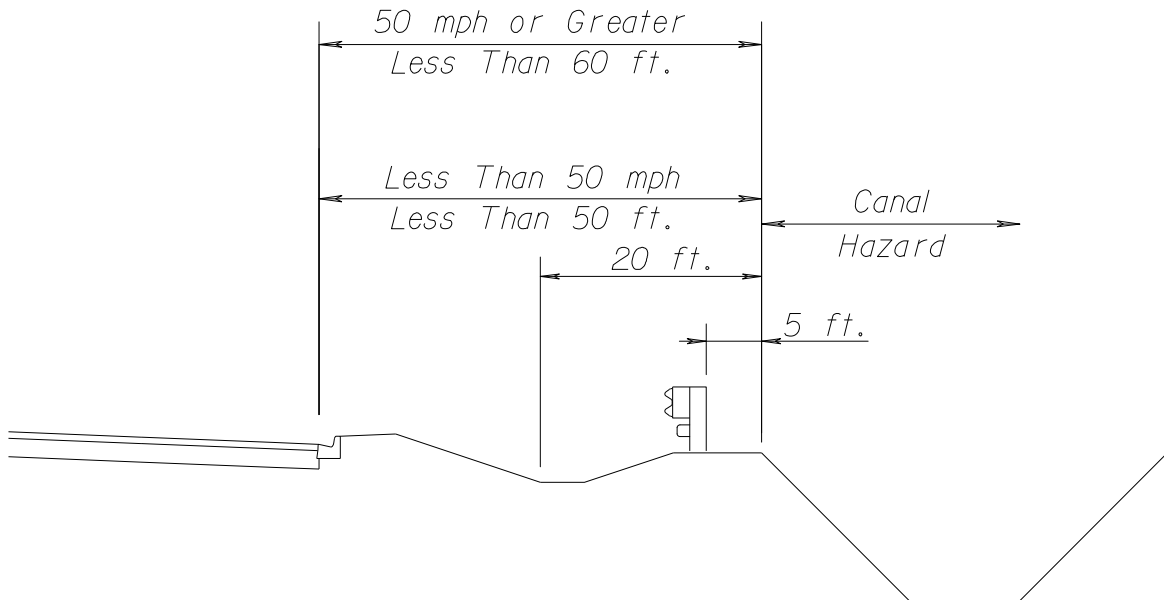
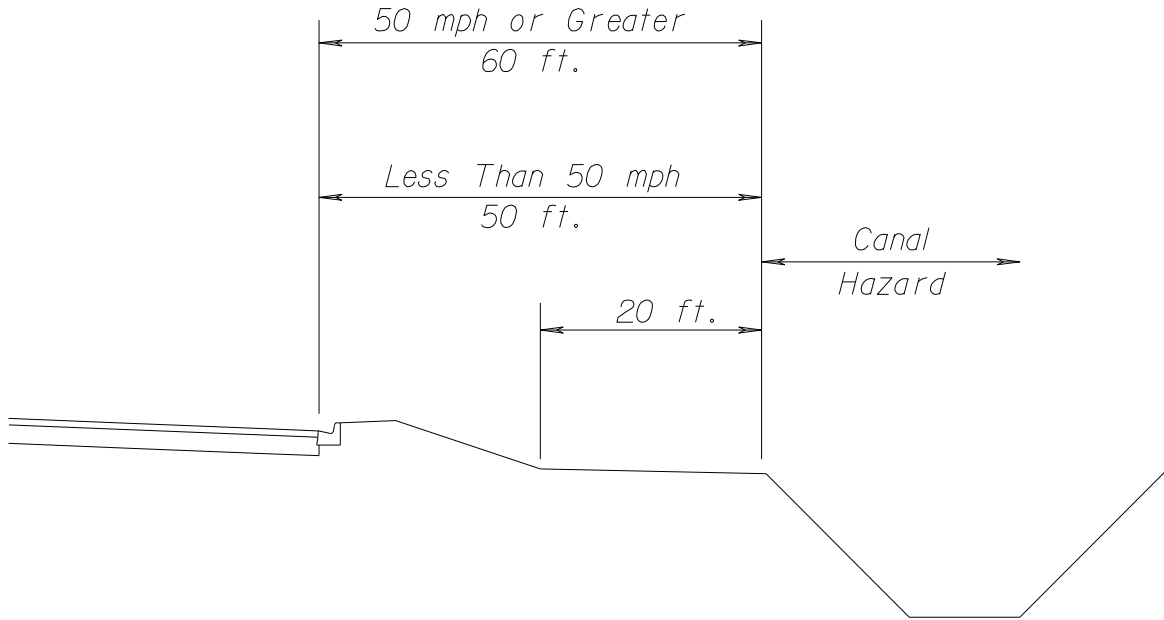

**Exhibit 4-B Minimum Standards for Canal Hazards
(Urban Curb or Curb and Gutter)**

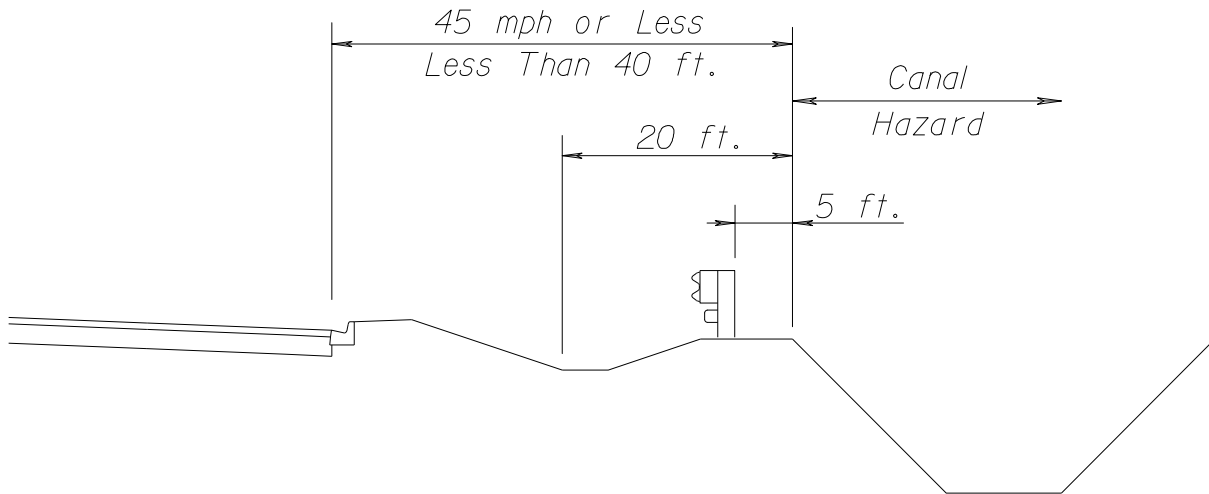
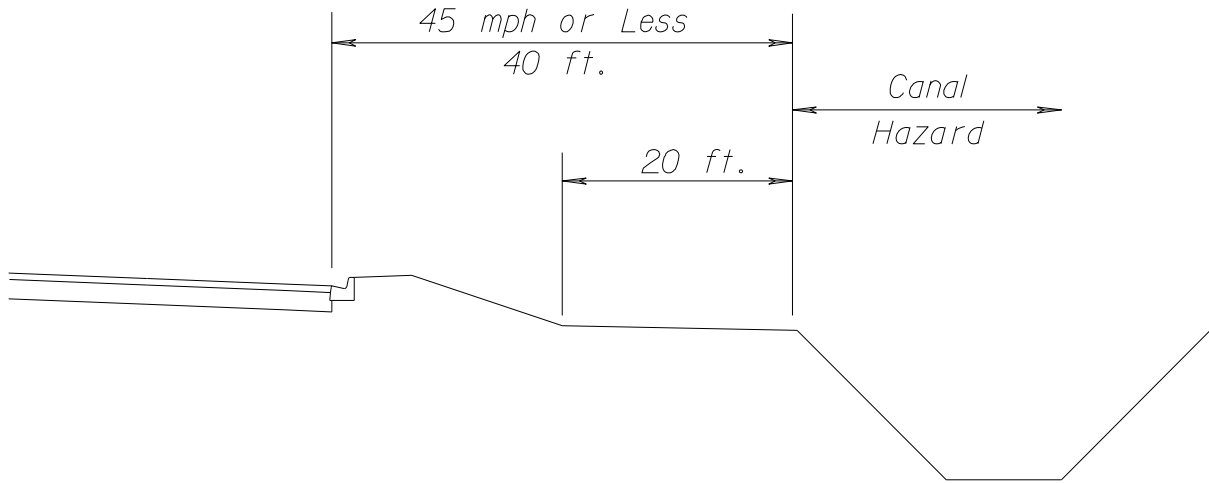

4.2.2 Drop-off Hazards

Drop-off hazards are defined as steep or abrupt downward slopes that can be perilous to vehicle occupants and/or pedestrians and cyclists. Shield any drop-off determined to be a hazard. The following guidelines will be useful in the identification and treatment of drop-off hazards.

Drop-off hazards for vehicle occupants:

1. A drop-off of 6 feet or more with a slope steeper than 1:3 should be considered a hazard and shielded when it is within the Clear Zone.
2. In urban sections with curb or curb and gutter (Design Speed \leq 45 mph), a drop-off of 6 feet or greater with a slope steeper than 1:3 located within 22 feet of the traveled way, should be evaluated for shielding.

Figure 4.2.2 Drop-off Hazards in Urban Sections

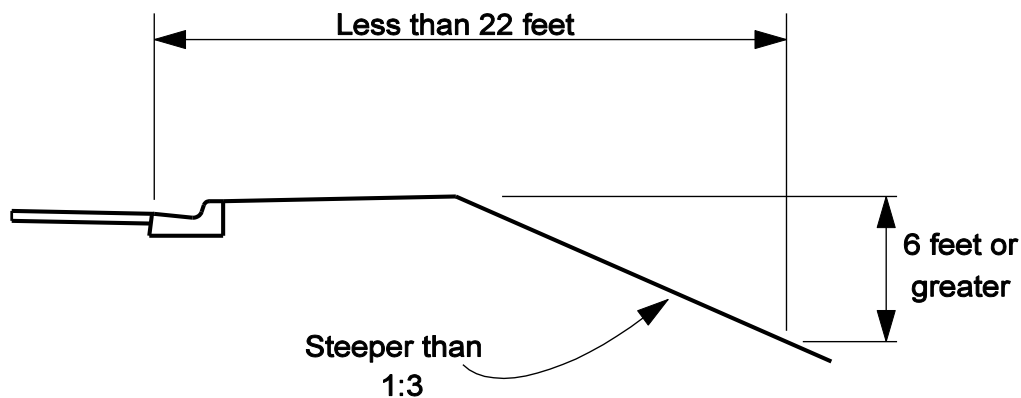

Shielding drop-off hazards for vehicle occupants:

1. When a drop-off is shielded, a guardrail or barrier is usually set closer to the road, which increases the probability of impacting the guardrail or barrier. These shields generally require the ends to be treated, which also needs to be taken into consideration. Refer to **Section 23.5** of this volume for guidance on evaluating the benefits of shielding a drop-off.

2. When a drop-off is to be shielded with guardrail, a minimum of 62.5 feet of guardrail is required to develop proper ribbon strength. A minimum clear area 5 feet wide from the face of the guardrail is to be provided behind the standard W-beam guardrail to allow for dynamic deflection when impacted. Use alternates shown in **Table 4.3.1** for clear areas less than 5 feet. A minimum distance of 2 feet shall be provided from the back face of the guardrail posts to the shoulder slope break in order to provide proper soil bearing resistance for the posts.
3. Another consideration is whether the drop-off has a significant crash history. Drop-offs that have had 3 crashes within a five-year period shall be shielded. Five years of crash data for a particular site can be obtained from the Safety Office.

For drop-off criteria in work zones see **Chapter 10** of this volume and **Index 600** of the **Design Standards**.

For drop-off hazards for pedestrians and bicyclists, see **Section 8.8** of this volume.

4.3 Roadside Barriers

Meet the drainage conveyance, utility, and structures conflict requirements of the ***Structures Design Guidelines (SDG), Section 3.13.1*** for earth retaining Roadside Barriers (e.g. ***Index 410***, Shoulder Walls, Cantilever Barrier Walls, L-Walls, or similar project specific designs).

4.3.1 Recommendations

Roadside barriers are recommended when hazards exist within the clear zone, hazards cannot be cost effectively eliminated or corrected, and collisions with the hazards are more serious than collisions with the barriers.

The length of advancement and length of need necessary to properly shield the hazard is determined on an installation by installation basis as indicated in the ***Design Standards***.

The following conditions within the clear zone are normally considered more hazardous than a roadside barrier:

1. Fill slopes steeper than 1:3.
2. Bridge piers, abutments and railing ends.
3. Non-traversable culverts, pipes and headwalls.
4. Non-traversable parallel or perpendicular ditches and canals.
5. Bodies of water other than parallel ditches and canals that the engineer determines to be hazardous.
6. Parallel retaining walls with protrusions or other potential snagging features.
7. Retaining walls at an approach angle with the edge of pavement larger than 7 degrees (1:8).
8. Non-breakaway sign or luminaire supports.
9. Trees greater than 4 inches in diameter measured 6 inches above the ground at maturity.
10. Utility poles.
11. Rigid protrusions above the ground in excess of 4 inches in height.

In addition to the above hazards, there are other situations which merit barrier consideration, such as nearby pedestrian or bicycle facilities, schools, residences or businesses.

4.3.2 Selection

Applicable standard roadside barriers are detailed in the *Design Standards*. They include:

1. Blocked-Out W-Beam (strong post)
2. Blocked-Out Thrie-Beam (strong post)
3. Modified Thrie-Beam (strong post)
4. Concrete Barrier Wall.

Most guardrail installations will be blocked-out W-beam on wood or steel posts. The use of the alternatives shown in **Table 4.3.1** should be considered when reduced deflection is needed. The use of thrie-beam guardrail should be considered when additional rail depth is needed because of a potential to under-ride the rail. Other barrier designs may be required by specific site conditions. Site specific conditions are identified and detailed in the plans on a project-by-project basis.

4.3.3 End Treatments

Longitudinal barrier ends which are not crashworthy can present serious hazards if they terminate within the clear zone. The Department's crashworthy end treatments and application criteria are detailed in the *Design Standards*. Under special circumstances, other end treatments may be designed as needed. When this is the case, special details are required in the plans.

1. For flared end anchorage assemblies, it is very important that the flare with offset be provided exactly as shown in the *Design Standards*. The end offset should be measured off a projection of the face of guardrail alignment. The maximum allowable cross slope in front of the rail is 1:10; this includes the area in front of and the upstream approach to the end anchorage assembly.
2. Non-crashworthy end treatments will be used outside the clear zone, and at downstream terminal locations, which are outside the clear zone of the opposing traffic flow. Type II end anchorage assemblies are non-crashworthy and, therefore, may **NOT** be used as an approach terminal end treatment unless other end shielding is provided.
3. Concrete barrier wall and thrie-beam guardrail shall be terminated as shown in the *Design Standards*.

4.3.4 Transitions

Guardrail transitions are necessary, whenever standard W-beam or thrie-beam guardrail converge with bridge rail or concrete barrier wall. Guardrail transitions must include sound structural connections, nested beams and additional posts for increased stiffness, as shown in the ***Design Standards***. Standard approach end anchors shall be introduced upstream of the transition section.

4.3.5 Placement

The primary design factors associated with guardrail placement are:

1. Lateral offset from the edge of travel way
2. Terrain effects
3. Departure rates
4. Length of Advancement
5. Length of Need

The standard offset is the shoulder width plus 2 ft., not to exceed 12 feet. Guardrail lateral offset locations are shown in the ***Design Standards***.

The distance of 2 ft. from the back of the barrier post to the shoulder line or slope break is desirable for post support.

The length of advancement is dependent on the design speed, the offset distance to the face of guardrail and the lesser distance (a) to the back of the hazard or (b) to the clear zone. The designer shall establish this length of advancement for all installations on the project. On all facilities, guardrail requirements must consider traffic from both directions.

A barrier should not be located so close to the hazard it shields that the hazard is within the dynamic deflection distance of the barrier. The minimum offset of barriers to the hazard being shielded is based on the dynamic deflection of standard barriers as shown in ***Table 4.3.1***. Setbacks for discontinuous attachments to standard FDOT traffic railings are shown in ***Figure 7.1.2.1***.

**Table 4.3.1 Minimum Offset of Barriers
 (Measured from the face of the barrier)**

BARRIER TYPE	OFFSET
W-Beam with Post Spacing @ 6'-3"	5'-0"
W-Beam with Post Spacing @ 3'-1½"	3'-10"
W-Beam with Post Spacing @ 1'-6¾"	3'-2"
Thrie-Beam with Post Spacing @ 6'-3"	3'-10"
Thrie-Beam with Post Spacing @ 3'-1½"	3'-2"
Thrie-Beam with Post Spacing @ 1'-6¾"	2'-10"
Concrete Barrier Wall	*
Double W-Beams (Nested) with Post Spacing @ 3'-1½"	3'-0"
Double W-Beams (Nested) with Post Spacing @ 1'-6¾"	2'-8"
Double Thrie-Beams (Nested) with Post Spacing @ 3'-1½"	2'-10"
Double Thrie-Beams (Nested) with Post Spacing @ 1'-6¾"	2'-6"

* These offsets are specifically provided in the **Design Standards**. For additional information on offsets to barriers see **Section 7.1.2**.

A single W-beam guardrail at a 1'-9" mounting height was tested in the study used to develop the design chart in **Figure 4.3.1**. This design chart has been updated for Traffic Railing/Concrete Barriers, Thrie-beam guardrail and W-beam guardrail at a 2'-1" mounting height. Within the design chart, there is a region between 0 feet and 13 feet (approx. 4 m) behind the face of the curb where guardrail should not be located. A traffic railing or concrete barrier, with the exception of F-Shapes with a height less than 42" may be used in any of the locations applicable to **Figure 4.3.1**. The preferred configuration is to place barriers at the face of curb.

Barriers should not be placed on slopes steeper than 1:10. This is particularly important for barrier ends shielded by crashworthy devices.

Figure 4.3.1 Placement of Curb-Barrier Combinations

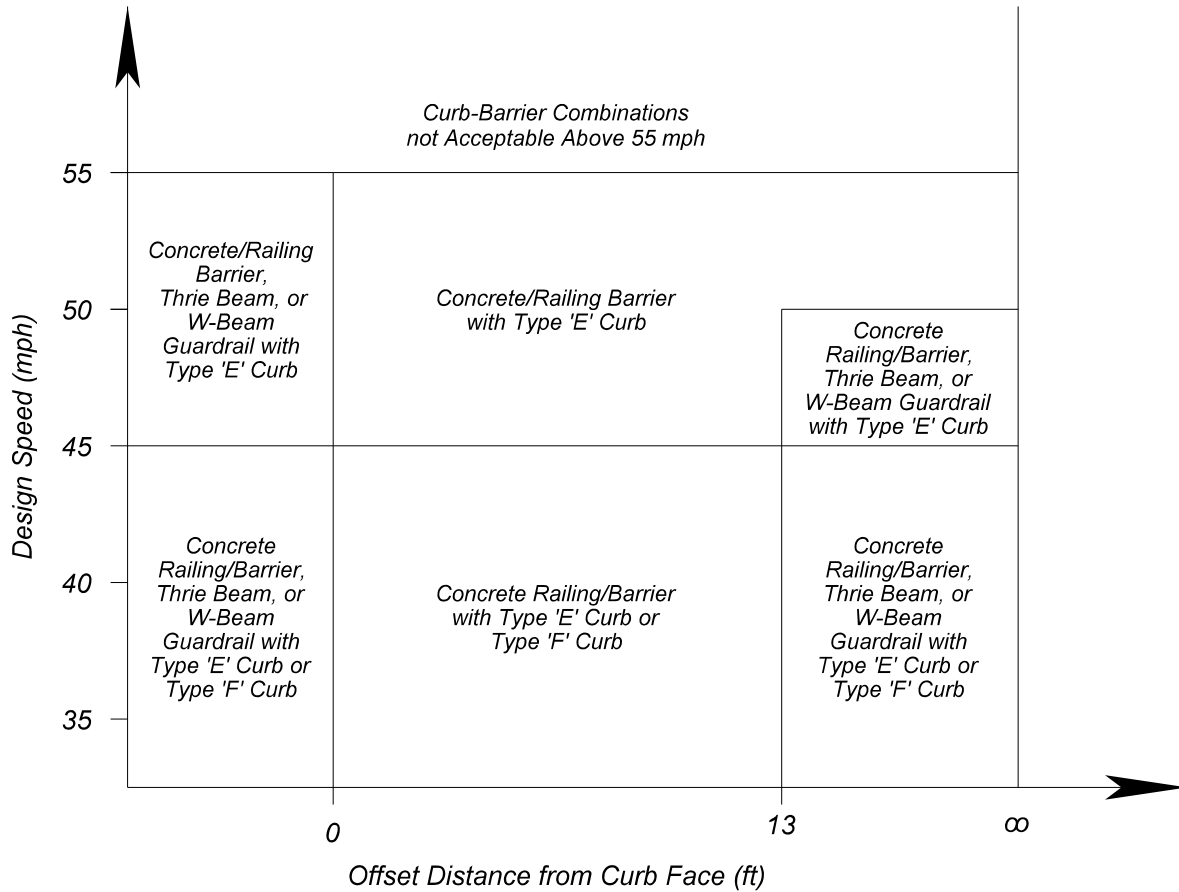

*Concrete Railing/Barrier includes 42" or 54" Pier Protection Barriers, 42" Vertical Shape, 32" Vertical Shape, 42" F-Shape, and Vertical Face Retrofits see **Index 480**.

4.3.6 Upgrading Existing Barrier Systems

Deficient roadside barriers are generally upgraded in conjunction with other roadway work, such as RRR projects, or through spot or system wide safety improvement projects. In each case, the designer determines the scope of work and extent of the barrier upgrade to be accomplished. In making this determination, the existing installation is investigated for what work is necessary to make the installation structurally and functionally adequate. The investigation should consider:

1. Whether there is a need for the barrier. If cost effective, the hazard should be removed, relocated, or redesigned and the barrier removed.
2. Length of need.
3. Proper rail height.
4. Proper departure rate.
5. Adequate offset at terminal end.
6. Proper deflection distance between the barrier and the shielded object.
7. Proper placement with respect to the travel way.
8. Proper placement with respect to the face of curb.
9. Placement on the proper slope.
10. Adequate clear recovery area behind gating end terminals.
11. The overall condition of the guardrail/barrier installation.
12. Post type, condition and spacing.
13. Existing unshielded hazards. For spot improvements, only those existing unshielded hazards in the immediate vicinity of the installation being addressed should be investigated. For RRR projects, all existing roadside hazards within the project corridor should be evaluated for adequate end treatment applications.

In some cases the deficiencies are so obvious that the best course of action is readily apparent. However, many times the deficiencies are marginal and a decision for the scope of work and extent of the barrier upgrade will be based on engineering judgment. Factors which should be considered are:

1. Nature and extent of barrier deficiency.
2. Past crash history.
3. Cost effectiveness of recommended improvement.

4. Whether future scheduled reconstruction or RRR work in the 5 year work program will address the deficiency.

For existing end treatments and bridge transitions with a 1'-9" mounting height W-beam guardrail system that does not meet the requirements of the **2013 Design Standards**, upgrade the system to bring it into compliance with the **2013 Design Standards**.

Where an existing system with 1'-9" mounting height guardrail meeting the requirements of the **2013 Design Standards** is to be extended, the decision of extending the section in-kind or replacing the entire run with a 2'-1" mounting height is at the discretion of the District.

4.3.6.1 Resetting Guardrail

For projects which include resetting guardrail, refer to the **Design Standards**, the **Standard Specifications**, and the **Basis of Estimates Manual** for quantity calculations, compensation notes, and pay item use.

When resetting existing guardrail, the guardrail shall be reset at the 2'-1" mounting height reusing existing posts and guardrail panels as shown in the current **Design Standards**.

4.3.7 Surface Finishes

Class 5 coatings, tints or stains may be applied to roadway concrete barrier walls in order to be compatible with the treatment of bridge or retaining wall mounted traffic railings or for corridor uniformity. Approval by the District Design Engineer is required for the use of Class 5 coatings, tints or stains on the outside of concrete roadside barriers. Approval by the Chief Engineer is required for the use of Class 5 coatings, tints or stains on median barriers and the inside and top surfaces of concrete roadside barriers. Abrupt changes of aesthetic treatment of barriers/railings/parapets from a bridge to a roadway should be avoided. See **SDG, Section 1.4.5** for the policy on bridge, noise wall and retaining wall surface finishes.

The Department will cover the cost for coating, tints or stains on roadway concrete barrier walls only as described above. If a Local Maintaining Agency desires a roadway concrete barrier wall with coatings, tints or stains and the barrier wall does not qualify for such treatment as determined by the Department, the barrier may be treated with approval by the District Secretary. The Local Maintaining Agency shall provide the additional construction funding for the coatings, tints or stains and shall commit to cover the associated maintenance costs for the service life of the barrier wall.

Modification for Non-Conventional Projects:

Delete **PPM 4.3.7** and see RFP for requirements.

4.4 Median Barriers

Meet the drainage conveyance, utility, and structures conflict requirements of the **SDG, Section 3.13.1** for earth retaining Median Barriers (e.g. **Index 410**, Shoulder Walls, Cantilever Barrier Walls, L-Walls, or similar project specific designs).

4.4.1 Recommendations

A median barrier shall be provided on interstate and expressway facilities where reconstruction reduces the median width to less than the standard for the facility. Note: the Engineer of Record shall not deviate from this criterion.

On Interstate and expressway projects, crashes that occurred in the most recent 5-year period within the limits of 1 mile prior to the exit ramp gore to 1 mile beyond the entrance ramp gore shall be reviewed. If one or more are determined to be cross median crashes, shielding within this area shall be provided. Outside these areas, the District may provide shielding after reviewing the most recent 5-year crash history.

4.4.2 Selection

The same barrier types as discussed in **Section 4.3.2** are available as median barriers. In general, the concrete barrier wall is preferable in narrow medians. Where deflection space is adequate, use either double faced guardrail or single faced guardrail on each side of the median. See the **Design Standards** and the **AASHTO Roadside Design Guide** for additional guidance on selection criteria.

4.4.3 End Treatments

Median barriers can be terminated with any end treatment discussed in **Section 4.3.3**.

4.4.4 Median Barrier Surface Finishes

See **Section 4.3.7** for surface finish requirements.

4.5 Permanent Crash Cushions

Crash cushions are energy absorbing devices that may be redirective or non-redirective. Permanent crash cushions consist of the redirective type, only.

4.5.1 Recommendations

Hazards within the clear zone, that present a more severe crash potential than crash cushions, warrant the installation of a crash cushion.

4.5.2 Selection

Various types of energy absorbing devices eligible for use on Department projects can be found on the Approved Products List (APL). Detailed information about these systems is provided in the **Design Standards**, approved APL drawings, and in each manufacturer's publications. Each system has unique physical and functional characteristics.

For permanent crash cushion applications, the designer shall indicate in the plans the location (station and side), barrier system (concrete barrier wall or guardrail), design length, design speed, crash test level, hazard width and all length restriction requirements for each given location (in accordance with **Design Standards, Index 430**, see **PPM, Volume 2, Chapter 7, Exhibit SQ-4**).

For site specific conditions, the engineer of record shall consider the following factors when evaluating each particular site:

1. Site characteristics.
2. Structural and safety characteristics of candidate systems.
3. Initial and replacement/repair costs.
4. Anticipated frequency of collisions.
5. Maintenance characteristics.

Site characteristics and economics dominate crash cushion consideration. Space constraints and length restrictions shall be identified by the design engineer and shown in the plans. Some crash cushion systems are relatively low in initial cost, but usually must be completely replaced when struck, so are more appropriate in locations with a low likelihood of collision. There are a number of other systems that have higher initial costs but can be repaired after collisions relatively quickly and inexpensively, so are more

appropriate where frequent collisions are anticipated. The ability of maintenance forces to perform routine maintenance and to place a crashed system back into service quickly should be a major consideration. Crash cushions that require stocking unusual and expensive parts or those are complex to replace should not be considered.

For future lettings, a pay item has been established for **Optional Crash Cushions, Pay Item No. 544-75-1**. This pay item is applicable for crash cushions being used to shield the ends of concrete barrier wall, standard W-beam guardrail, or thrie-beam guardrail. Use of this pay item for these locations is required. For crash cushions used to shield hazards other than concrete barrier wall, standard W-beam guardrail, or thrie-beam guardrail, designers must continue to identify specific constraints to include; design length, hazard width, and system length restrictions.

Modification for Non-Conventional Projects:

Delete the first three sentences of the above paragraph.

The crash cushion pay item is to be used in conjunction with **Index 430** of the **Design Standards**. **Index 430** includes design information for both concrete barrier wall and guardrail applications. In either case, establish the end of the barrier based on the design length of the shortest crash cushion for a given design speed. For space constraints and length restrictions, designers should note that certain crash cushions may have lengths that exceed the available space or may have lengths that do not provide the proper length of need for each location.

4.5.3 Design

Standard details of systems for typical installations shielding concrete barrier wall ends and guardrail ends can be found on the approved APL drawings. In addition, some of these systems have standard details for shielding wide hazards. For non standard applications, crash cushion suppliers normally provide design assistance for their systems. Special designs should be based on providing performance meeting crash test criteria for the established design speed of the facility.

All terrain within the likely approach of a vehicle should be relatively flat. An impacting vehicle should strike the unit at normal height, with the vehicle's suspension system neither collapsed nor extended. Curbs shall not be built in the approach area of a crash cushion.

The design of a crash cushion system shall not create a hazard to opposing traffic.

The nose of all crash cushions shall be delineated with reflective material or standard object markers, as indicated in the ***Design Standards***.

For additional guidance on the design and selection of temporary crash cushions for use in work zones, see ***Chapter 10***.

4.6 Roadside Appurtenances

4.6.1 Sign Supports

All sign supports, except overhead cantilever, truss type or bridge or barrier wall mounted, shall be breakaway as defined in the ***AASHTO Standard Specifications for Structural Supports for Highway Signs, Luminaires and Traffic Signals*** and the ***AASHTO Roadside Design Guide***. Sign supports shall be of an acceptable and crashworthy design as described in the ***Design Standards***. Supports not meeting the breakaway criteria should not be installed within the clear zone. Sign supports not meeting these requirements that must be installed within the clear zone, shall be protected by a barrier or crash cushion.

4.6.2 Mailbox Supports

Mailbox supports shall be of an acceptable crashworthy design, as described in the ***Design Standards***.

4.6.3 Other Appurtenances

The ***Design Standards*** contains design criteria for numerous other roadside appurtenances.

4.6.4 Location Criteria

Most breakaway mechanisms are designed to be impacted at bumper height, typically about 20 inches above the ground. If impacted at a significantly higher point, the bending moment in the breakaway base may be sufficient to bind the mechanism, resulting in non-activation of the breakaway device. For this reason, it is important that breakaway supports not be located in ditches or on steep slopes where a vehicle is likely to be partially in sprung suspension at the time of impact.

4.6.5 Bus Benches and Transit Shelters

Refer to ***Table 2.11.9*** for criteria on the placement of shelters and benches.

4.7 Non-Standard Roadside Safety Devices

The Approved Products List (APL) includes proprietary devices and products that have been evaluated against implemented FDOT Specifications and Standards, and found to meet those Specifications and/or Standards. The majority of proprietary roadside safety devices eligible for use on the State Highway System are identified on the APL. However, just as FDOT Specifications and Standards do not address every potential highway need, the APL does not cover every type of roadside safety device that may be available on the market. Unique situations will sometimes require unique devices. Examples of available devices that are not covered by FDOT Specifications and Standards include barrier wall gates, aesthetic guardrail, temporary steel barriers, crashworthy stop gates, cable barrier, and others. When the need arises for a unique crashworthy device not included on the APL, the designer must carefully investigate the applicability of the device for the situation, as well as the crash performance characteristics of the device. For some of these devices, the State Roadway Design Office may have information and be of assistance in establishing the appropriateness of the device for a given situation.

The designer must document the following:

1. FHWA, Federal-Aid Reimbursement Eligibility Letter
2. Crash Test Reports, including review of all test results. All performance characteristics must be reviewed, including post impact vehicle behavior and post impact test article deflection, debris scatter, etc.
3. Compatibility with adjacent and/or connecting standard roadside safety devices.
4. Maintenance requirements and characteristics, including coordination with the District Maintenance Office.
5. For devices such as barrier gates, operational plans and training as appropriate.

The designer will also be responsible for providing special plan details, technical specifications, and method of pay as appropriate.