

PERMANENT RETAINING WALL SYSTEM DATA TABLES

GEOTECHNICAL INFORMATION						
		Reinforced Soil & Random Backfill	Loose Fine Sand	Firm Fine Sand	Loose Clayey Fine Sand	Firm Clayey Fine Sand
Depth Below Existing Ground Line (ft.)	Wall No. 1 & 2	—	0'-6'	6'-33'	33'-39'	—
	Wall No. 3	—	0'-10'	10'-26'	—	26'-39'
Effective Unit Weight (pcf)		110 (moist weight in-place)	118	118	120	110
Cohesion (psf)		0	0	0	122	122
Internal Friction Angle		30°	30°	32°	0	0

NOTE:  
If the unit weight and/or internal friction angle of the fill proposed by the Contractor differs from that shown above, the Project Engineer will contact both the District Geotechnical Engineer and the Wall Designer for a possible redesign.

RETAINING WALL VARIABLES				
Wall No.	Wall Settlement			
	Long Term Settlement (in.)	Short Term Settlement (in.)	Differential Settlement	
			Longitudinal (%) (ft./100ft.)	Transverse (in.)
1 & 2	2" to 3"	1" to 2"	0.50	N/A
3	2" to 3"	1" to 2"	0.50	N/A

NOTE:  
Design walls for the settlements noted in the table.  
Long term settlement is measured from the end of wall fill placement.  
Transverse differential settlement is measured from the face of wall to the end of the soil reinforcement.

SOIL REINFORCEMENT LENGTHS FOR EXTERNAL STABILITY												
Wall No. 1 & 2	Wall Height (ft.)	0-11	12	13-14	15	16-17	18	19-20	21	22-23	24	25
	Reinforcement Length (ft.)	8	9	10	11	12	13	14	15	16	17	18
	Factored Bearing Resistance (psf)	1984	2295	2546	2857	3108	3419	3671	3980	4233	4543	4851
Wall No. 3	Wall Height (ft.)	0-11	12	13-14	15	16-17	18	19-20	—	—	—	—
	Reinforcement Length (ft.)	8	9	10	11	12	13	14	—	—	—	—
	Factored Bearing Resistance (psf)	2467	2467	2467	2467	2467	2467	2467	—	—	—	—

NOTES:  
1. The reinforcement strap lengths shown above are the minimum lengths required for external stability. The reinforcement lengths used in the construction of the retaining walls will be the longer of that required for external or internal stability (determined by proprietary wall companies).  
2. The Factored Bearing Resistances shown above are the critical (lowest) values from all the load cases analyzed using LRFD methodology.

NOTES:

- Concrete facing panels surfaces treatment will be a fluted, trapezoid, V-groove, fractured rib 3/4" on 1 1/2" centers similar to Burke Form Liner, Pattern No. BG312 (Waterfall).
- If required, the soil reinforcement and fasteners for the abutment back wall will be designed and furnished by proprietary wall company. The soil reinforcement will be designed to resist a factored horizontal load of 3.5 kips/ft of back wall width. The cost of soil reinforcement and fasteners will be included in the cost of the retaining wall system.
- Applicable FDOT Wall Types for each wall location are listed below. See the Qualified Products List for approved wall systems and the Table of FDOT Wall Types on Index No. 5300 of the Design Standards for allowable wall type substitutions.

Wall No. 1, 2 & 3 - FDOT Wall Type 2B

4. See Design Standards Index No. 5300 for General Notes And Details.

5. Longitudinal dimensions shown in the plans are measured along the exterior face of the wall. Elevations shown are to the top of coping, top of leveling pad or top of wall footing.

Note: Use CADD Cell "05300".  
Work this cell with Design Standards, Index No. 5300.

EXHIBIT CP-1  
Date: 1/1/10

REVISIONS						DRAWN BY:			SHEET TITLE:			REF. DWG. NO.	
DATE	BY	DESCRIPTION	DATE	BY	DESCRIPTION	XXX MM-YY	XXX MM-YY	XXX MM-YY	STATE OF FLORIDA DEPARTMENT OF TRANSPORTATION			PERMANENT MSE WALL DATA TABLES AND NOTES	
									ROAD NO.	COUNTY	FINANCIAL PROJECT ID	PROJECT NAME:	SHEET NO.

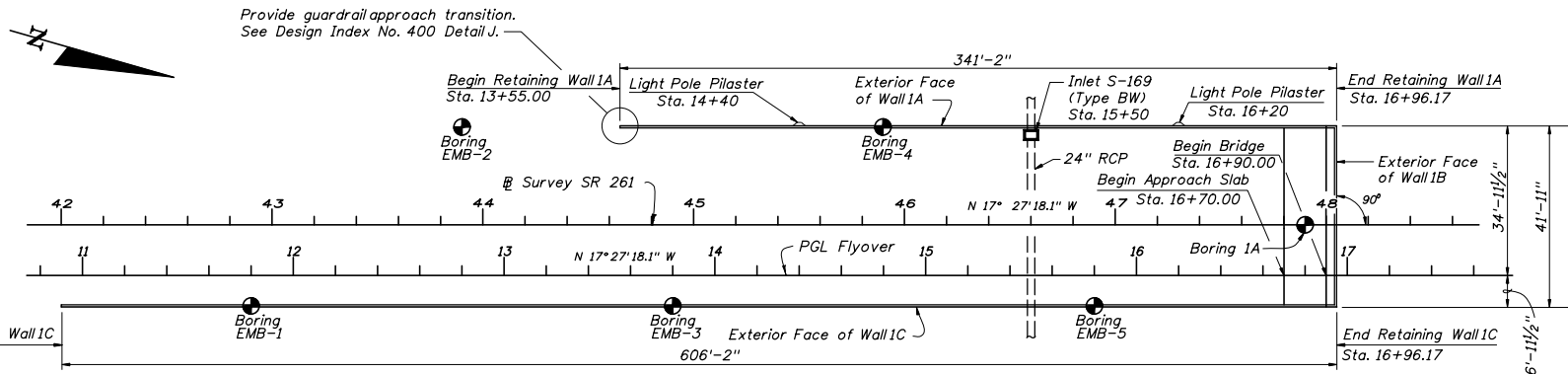

**NOTES:**

1. For Top of Coping Elevations see sheet BW-6.
2. Top of Leveling Pad shall be a minimum of 2'-0" below Proposed Ground Line.
3. Provide 3/4" open joints in Traffic Railing at a maximum of 90 ft. intervals.
4. ● indicates Soil Boring. See Sheets B-8 thru B-12a for boring data.
5. For Additional Information regarding Drainage Structures and Utility Locations, See Roadway Plans.

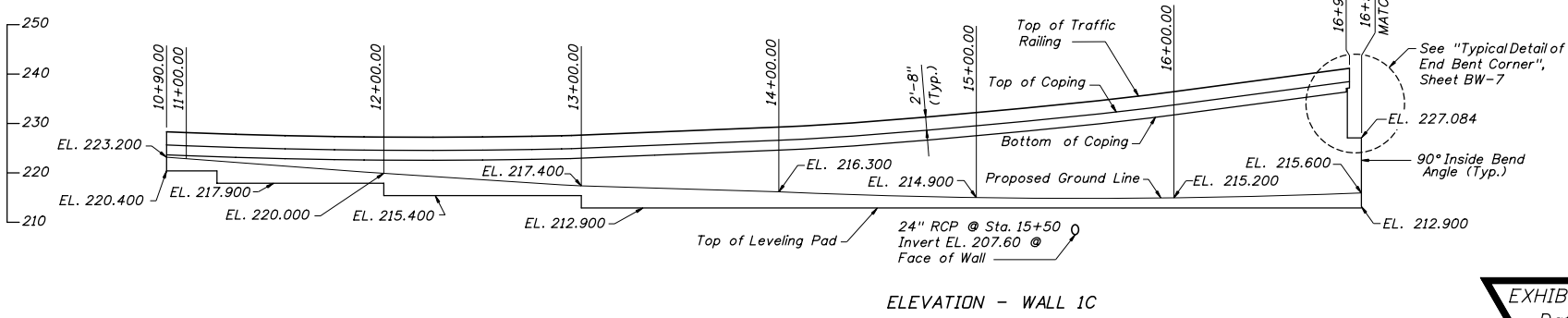
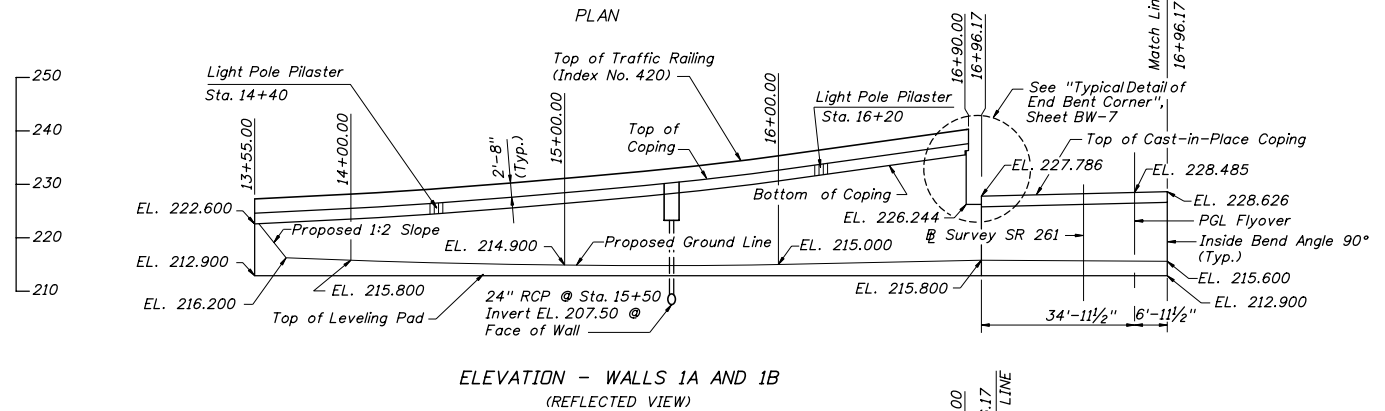

**EXHIBIT CP-2**  
Date: 1/1/10

REVISIONS						DRAWN BY:			SHEET TITLE:			REF. DWG. NO.	
DATE	BY	DESCRIPTION	DATE	BY	DESCRIPTION	XXX MM-YY	XXX MM-YY	XXX MM-YY	STATE OF FLORIDA	MSE WALL NO. 1 CONTROL DRAWING			
						XXX MM-YY	XXX MM-YY	XXX MM-YY	DEPARTMENT OF TRANSPORTATION				
						XXX MM-YY	XXX MM-YY	XXX MM-YY	ROAD NO.	COUNTY	FINANCIAL PROJECT ID	PROJECT NAME	
						XXX MM-YY	XXX MM-YY	XXX MM-YY					SHEET NO.

NOTICE: THE OFFICIAL RECORD OF THIS SHEET IS THE ELECTRONIC FILE SIGNED AND SEALED UNDER RULE 61G15-23.003, F.A.C.

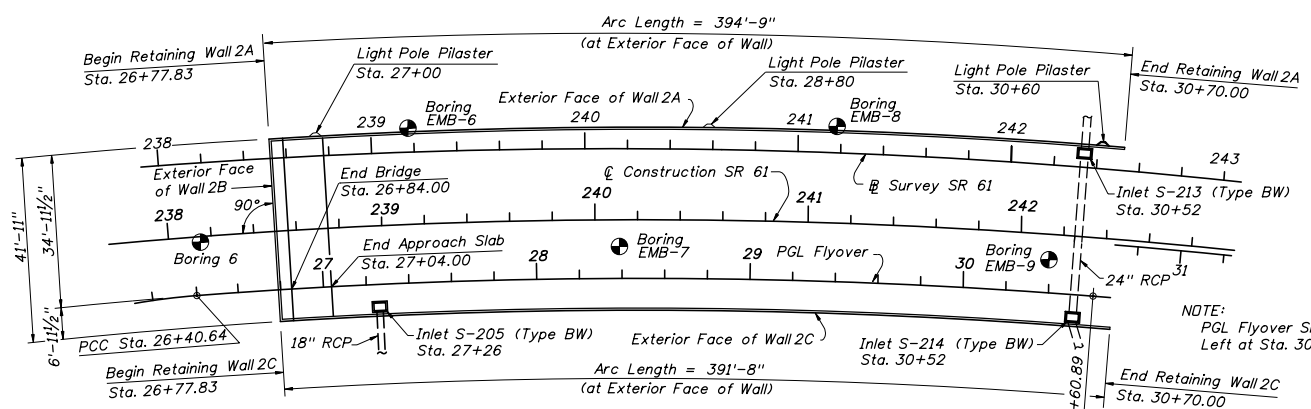

**HORIZONTAL CURVE DATA**

PI Sta. = 28+50.87  
 $\Delta = 4^{\circ}28'13''$  Rt.  
 $D = 1^{\circ}02'54''$   
 $T = 210.23'$   
 $L = 420.25'$   
 $R = 5,386.25'$   
PCC Sta. = 26+40.64  
PT Sta. = 30+60.89

NOTE:  
PGL Flyover Shifts 12'-0"  
Left at Sta. 30+69.23

**PLAN**

250  
240  
230  
220  
210

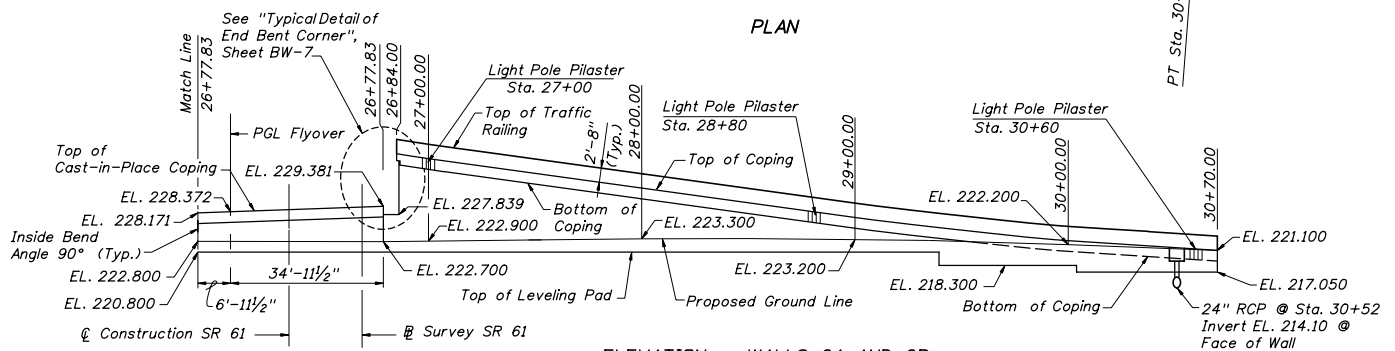

**ELEVATION - WALLS 2A AND 2B  
(REFLECTED VIEW)**

250  
240  
230  
220  
210

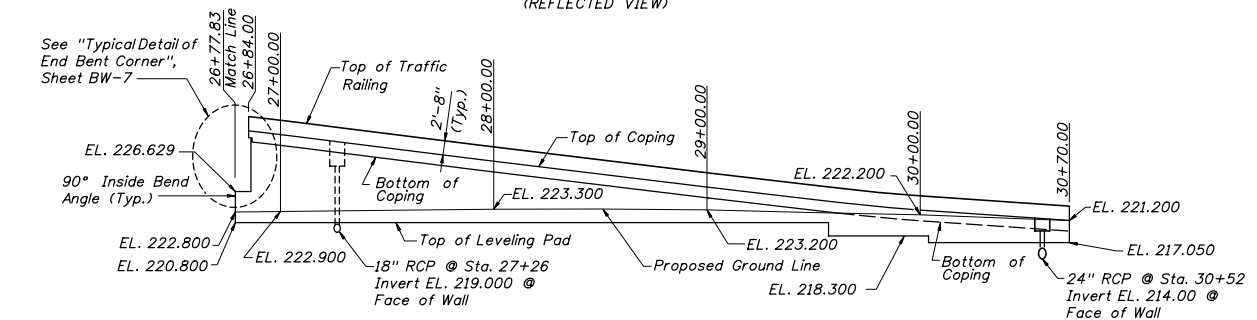

**ELEVATION - WALL 2C**

**STATE PLANE COORDINATES**

N E  
PCC  
PI (Not Available)  
PT

**NOTES:**

- For Top of Coping Elevations see sheet BW-4.
- Top of Leveling Pad shall be a minimum of 2'-0" below Proposed Ground Line.
- Provide  $\frac{3}{4}$ " open joints in Traffic Railing at a maximum of 90 ft. intervals.
- ⊙ indicates Soil Boring. See Sheets B-8 thru B-12a for boring data.
- For Additional Information regarding Drainage Structures and Utility Locations, See Roadway Plans.

**EXHIBIT CP-3**  
Date: 1/1/10

REVISIONS				DRAWN BY:			SHEET TITLE:			REF. DWG. NO.
DATE	BY	DESCRIPTION	DATE	BY	DESCRIPTION	XXX MM-YY	STATE OF FLORIDA DEPARTMENT OF TRANSPORTATION			MSE WALL NO. 2 CONTROL DRAWING
							ROAD NO.	COUNTY	FINANCIAL PROJECT ID	PROJECT NAME:

NOTICE: THE OFFICIAL RECORD OF THIS SHEET IS THE ELECTRONIC FILE SIGNED AND SEALED UNDER RULE 61G15-23.003, F.A.C.

WALL No. 1A

PGL Flyover Station	Exposed Face of Wall 1A Offset from PGL Flyover (ft.)	Top of Coping Elevation @ Wall 1A (ft.)
13+55.00	34.958	224.600
13+75.00	34.958	224.969
14+00.00	34.958	225.503
14+25.00	34.958	226.116
14+50.00	34.958	226.809
14+75.00	34.958	227.583
15+00.00	34.958	228.436
15+25.00	34.958	229.370
15+50.00	34.958	230.383
15+75.00	34.958	231.477
16+00.00	34.958	232.650
16+25.00	34.958	233.904
16+50.00	34.958	235.390
16+75.00	34.958	236.848
16+90.00	34.958	237.615

WALL No. 2A

PGL Flyover Station	Exposed Face of Wall 2A Offset from PGL Flyover (ft.)	Top of Coping Elevation @ Wall 2A (ft.)
26+78.83	34.958	-
26+84.00	34.958	239.246
27+00.00	34.958	238.327
27+25.00	34.958	236.948
27+50.00	34.958	235.569
27+75.00	34.958	234.191
28+00.00	34.958	232.812
28+25.00	34.958	231.433
28+50.00	34.958	230.055
28+75.00	34.958	228.676
29+00.00	34.958	227.297
29+25.00	34.958	226.058
29+50.00	34.958	224.927
29+75.00	34.958	223.891
30+00.00	34.958	222.950
30+25.00	34.958	222.109
30+50.00	34.958	221.525
30+70.00	22.958	221.121

WALL No. 1C

PGL Flyover Station	Exposed Face of Wall 1C Offset from PGL Flyover (ft.)	Top of Coping Elevation @ Wall 1C (ft.)
10+90.00	6.958	225.647
11+00.00	6.958	225.486
11+25.00	6.958	225.139
11+50.00	6.958	224.872
11+75.00	6.958	224.685
12+00.00	6.958	224.578
12+25.00	6.958	224.551
12+50.00	6.958	224.604
12+75.00	6.958	224.737
13+00.00	6.958	224.950
13+25.00	6.958	225.243
13+50.00	6.958	225.616
13+75.00	6.958	226.069
14+00.00	6.958	226.603
14+25.00	6.958	227.216
14+50.00	6.958	227.909
14+75.00	6.958	228.683
15+00.00	6.958	229.536
15+25.00	6.958	230.470
15+50.00	6.958	231.483
15+75.00	6.958	232.577
16+00.00	6.958	233.750
16+25.00	6.958	235.004
16+50.00	6.958	236.323
16+75.00	6.958	237.648
16+90.00	6.958	238.477
16+93.50	6.958	-

WALL No. 2C

PGL Flyover Station	Exposed Face of Wall 2C Offset from PGL Flyover (ft.)	Top of Coping Elevation @ Wall 2C (ft.)
26+78.83	6.958	-
26+84.00	6.958	238.015
27+00.00	6.958	237.310
27+25.00	6.958	236.055
27+50.00	6.958	234.804
27+75.00	6.958	233.554
28+00.00	6.958	232.314
28+25.00	6.958	231.102
28+50.00	6.958	229.890
28+75.00	6.958	228.678
29+00.00	6.958	227.466
29+25.00	6.958	226.258
29+50.00	6.958	225.127
29+75.00	6.958	224.091
30+00.00	6.958	223.150
30+25.00	6.958	222.307
30+50.00	6.958	221.656
30+70.00	18.958	221.201

- NOTES:  
 1. Offsets are given to the exterior face of the proprietary wall.  
 2. For proposed ground elevations for all walls, see Sheets BW-2 and BW-3.

**EXHIBIT CP-4**  
 Date: 1/1/10

REVISIONS						DRAWN BY: XXX MM-YY			STATE OF FLORIDA DEPARTMENT OF TRANSPORTATION			SHEET TITLE: MSE WALLS NOS. 1 AND 2 ELEVATIONS		REF. DWG. NO.
DATE	BY	DESCRIPTION	DATE	BY	DESCRIPTION	CHECKED BY: XXX MM-YY	ROAD NO.	COUNTY	FINANCIAL PROJECT ID	PROJECT NAME	SHEET NO.			

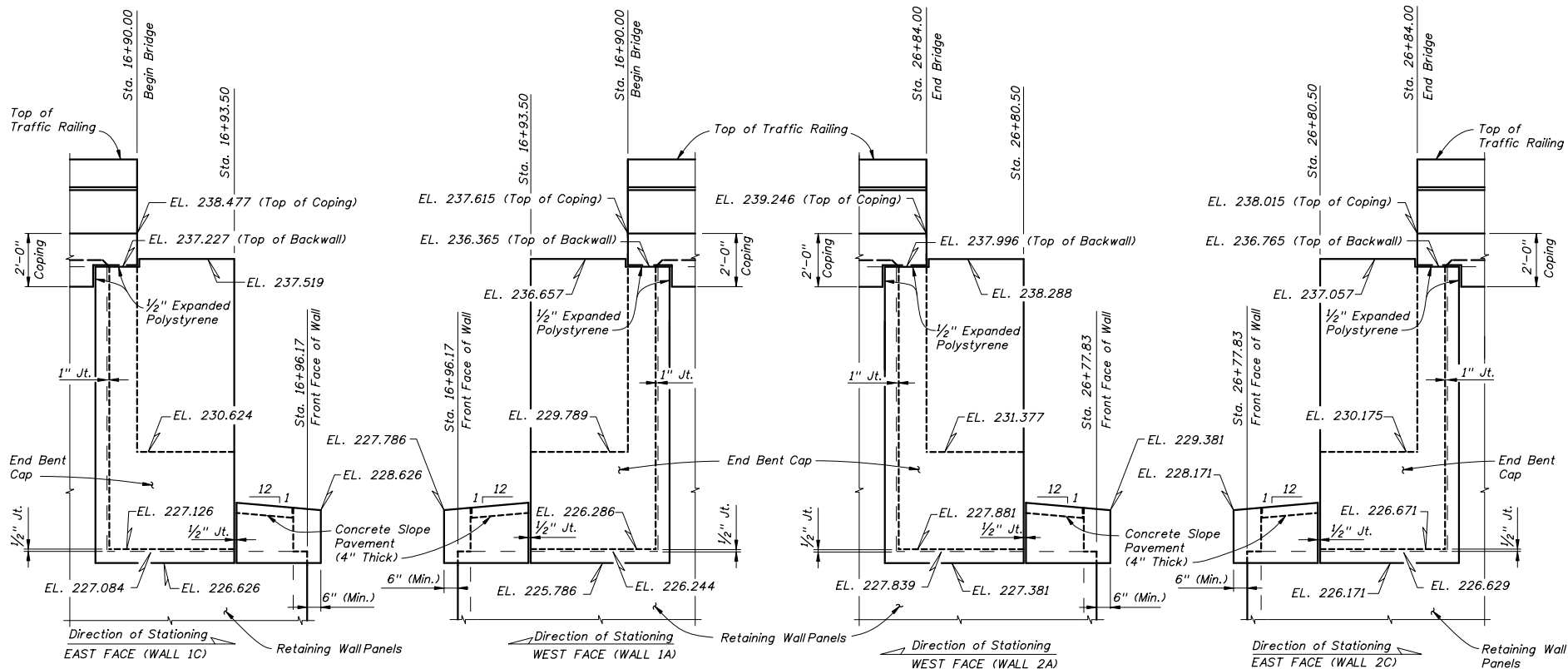

END BENT NO. 1

END BENT NO. 7

NOTE:  
 1/2" and 1" Joints to be  
 Preformed Joint Filler,  
 unless otherwise shown.

EXHIBIT CP-5  
 Date: 1/1/10

REVISIONS						DRAWN BY: XXX MM-YY	STATE OF FLORIDA DEPARTMENT OF TRANSPORTATION			SHEET TITLE: MSE WALLS MISCELLANEOUS DETAILS	REF. DWG. NO.
DATE	BY	DESCRIPTION	DATE	BY	DESCRIPTION		ROAD NO.	COUNTY	FINANCIAL PROJECT ID		

#USER# #DATE# #TIME# #FILES#

NOTICE: THE OFFICIAL RECORD OF THIS SHEET IS THE ELECTRONIC FILE SIGNED AND SEALED UNDER RULE 61G15-23.003, F.A.C.

TEMPORARY RETAINING WALL SYSTEM DATA TABLES

GEOTECHNICAL INFORMATION						
		Reinforced Soil & Random Backfill	Loose Fine Sand	Firm Fine Sand	Loose Clayey Fine Sand	Firm Clayey Fine Sand
Depth Below Existing Ground Line (ft.)	Wall No. 1	—	0'-9'	9'-23'	23'-37'	37'-45'
	Wall No. 2	—	0'-9'	9'-23'	23'-37'	37'-45'
Effective Unit Weight (pcf)		110	118	118	120	110
Cohesion (psf)		0	0	0	0	0
Internal Friction Angle		30°	34°	34°	35°	30°
Depth Below Existing Ground Line (ft.)	Wall No. 3	—	0'-10'	10'-15'	15'-17'	17'-45'
	Wall No. 4	—	0'-10'	10'-15'	15'-17'	17'-45'
Effective Unit Weight (pcf)		110	116	118	120	116
Cohesion (psf)		0	0	0	4177	0
Internal Friction Angle		30°	32°	34°	0	34°

NOTES:

1. See the Qualified Products List for approved Wall Systems (Type 3).
2. See Design Standards Index No. 5301 for General Notes and Details

NOTE:

If the unit weight and/or internal friction angle of the fill proposed by the Contractor differs from that shown above, the Project Engineer will contact both the District Geotechnical Engineer and the Wall Designer for a possible redesign.

RETAINING WALL VARIABLES				
Wall No.	Wall Settlement			Air Contaminants Classification
	Long Term Settlement (in.)	Short Term Settlement (in.)	Differential Settlement (%) (ft./100 ft.)	
1 & 2	1/2"	3/8"	0.50	Extremely Aggressive
3 & 4	1/2"	1/4"	0.50	Extremely Aggressive

NOTE:

Design walls for the settlements noted in the table. Long term settlement is measured from the beginning of wall construction.

SOIL REINFORCEMENT LENGTHS FOR EXTERNAL STABILITY											
Walls 1 thru 4	Wall Height (ft.)	5'-0"	5'-6"	6'-0"	6'-6"	7'-0"	7'-6"				
	Reinforcement Length (ft.)	7'-0"	7'-0"	7'-0"	7'-0"	7'-0"	7'-0"				
	Factored Bearing Resistance (psf)	1082	1241	1426	1648	1454	1623				

NOTES:

1. The reinforcement strap lengths shown above are the minimum lengths required for external stability. The reinforcement lengths used in the construction of the retaining walls will be the longer of that required for external or internal stability (determined by proprietary wall companies).
2. The Factored Bearing Resistances shown above are the critical (lowest) values from all the load cases analyzed using LRFD methodology.

Note: Use CADD Cell "05301".  
Work this cell with Design Standards, Index No. 5301.

EXHIBIT CP-6  
Date: 1/1/10

REVISIONS						DRAWN BY:			STATE OF FLORIDA			SHEET TITLE:			REF. DWG. NO.
DATE	BY	DESCRIPTION	DATE	BY	DESCRIPTION	XXX MM-YY	XXX MM-YY	XXX MM-YY	DEPARTMENT OF TRANSPORTATION			TEMPORARY MSE WALL DATA TABLES AND NOTES			
									ROAD NO.	COUNTY	FINANCIAL PROJECT ID	PROJECT NAME:			

#USER# #DATE# #TIME# #FILE#

NOTICE: THE OFFICIAL RECORD OF THIS SHEET IS THE ELECTRONIC FILE SIGNED AND SEALED UNDER RULE 61G15-23.003, F.A.C.



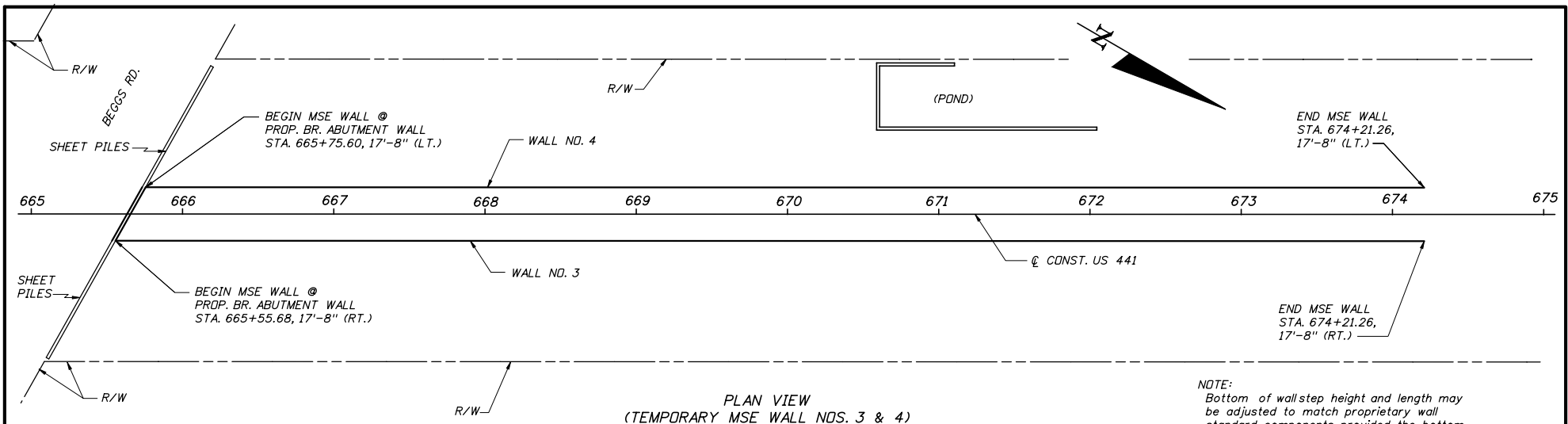

**NOTE:**  
Bottom of wall step height and length may be adjusted to match proprietary wall standard components provided the bottom of the wall remains below existing ground.

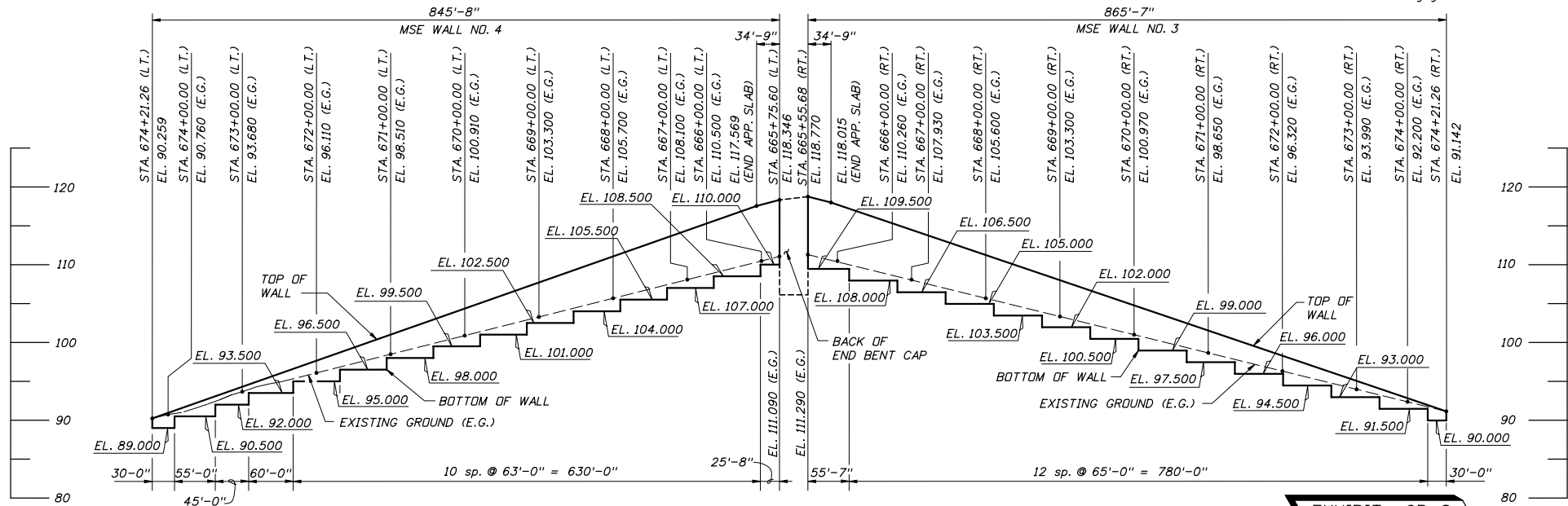

**EXPANDED ELEVATION VIEW  
(TEMPORARY MSE WALL NOS. 3 & 4, LOOKING AT FRONT FACE OF WALL)**

**EXHIBIT CP-8  
Date: 1/1/10**

REVISIONS				DRAWN BY:		SHEET TITLE:		REF. DWG. NO.
DATE	BY	DESCRIPTION	DATE	BY	XXX MM-YY	TEMPORARY MSE WALL NOS. 3 & 4 CONTROL DRAWING		
					CHECKED BY:	STATE OF FLORIDA DEPARTMENT OF TRANSPORTATION		
					DESIGNED BY:	ROAD NO.	COUNTY	FINANCIAL PROJECT ID
					CHECKED BY:	PROJECT NAME:		SHEET NO.
						#USER#	#DATE#	#TIME#
							#FILES#	

NOTICE: THE OFFICIAL RECORD OF THIS SHEET IS THE ELECTRONIC FILE SIGNED AND SEALED UNDER RULE 61G15-23.003, F.A.C.