

- GENERAL NOTES**
- SURFACE TREATMENT:** As an option to Class 4 Floor Finish (Bridge Floor Grooving) per Section 400 a hand tined or heavy broomed finish may be permitted on the concrete portion of the riding surface. Sidewalk areas shall receive a broomed finish. The top surface of the concrete beneath the asphalt overlay shall be raked.
 - CONDUIT:** If required, see Structures Plans for Conduit Details.
 - When a longitudinal construction joint is necessary or allowed by the Engineer, the transverse steel shall be extended as shown in the Longitudinal Construction Joint Detail.
 - The plan view for CASE 1 applies when the skew angle (θ) = 0°.
 - The plan view for CASE 2 applies where the skew angle (θ) is > 0°. The slab shown represents a skew to the right for an approach slab at begin bridge; approach slab at the end of bridge or a left skew shall be treated similarly.
 - Welded Wire Reinforcement (WWR) for the edge of Approach Slabs on retaining walls is not included in the estimated quantity for reinforcing steel and is considered incidental to the work. WWR must consist of Deformed wire meeting the requirements of Specification Section 931.
 - Continue the asphalt pavement over the approach slab and match the friction course type used on the roadway. See the Roadway Plans for asphalt overlay and optional base details.
 - Approach slabs shown in Plan View Cases 1 and 2 represent a typical approach slab with edge barriers and no sidewalks. Provide railings, parapets and raised sidewalks as detailed in the Contract Plans.

CROSS REFERENCES:

For Section B-B, Longitudinal Construction Joint Detail and Approach Slab Details see Sheet 2.

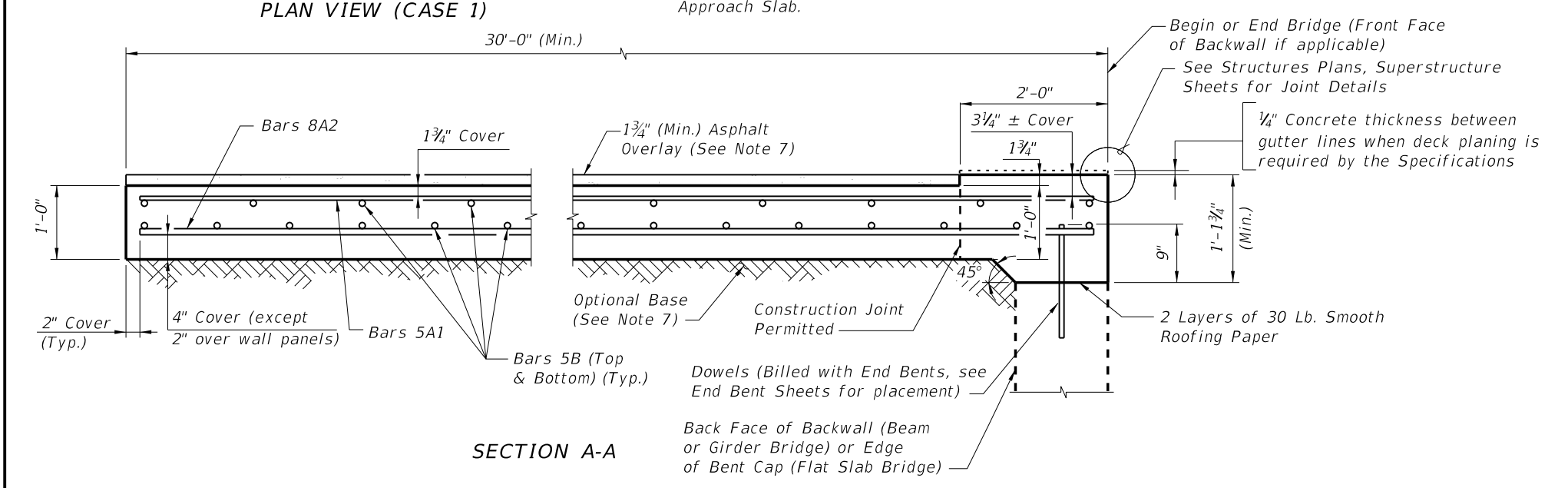

LAST REVISION 07/01/14	REVISION	DESCRIPTION:	FDOT 2015 DESIGN STANDARDS	APPROACH SLABS (FLEXIBLE PAVEMENT APPROACHES)	INDEX NO.	SHEET NO.
					20900	1 of 2

5/22/2014 1:55:02 PM

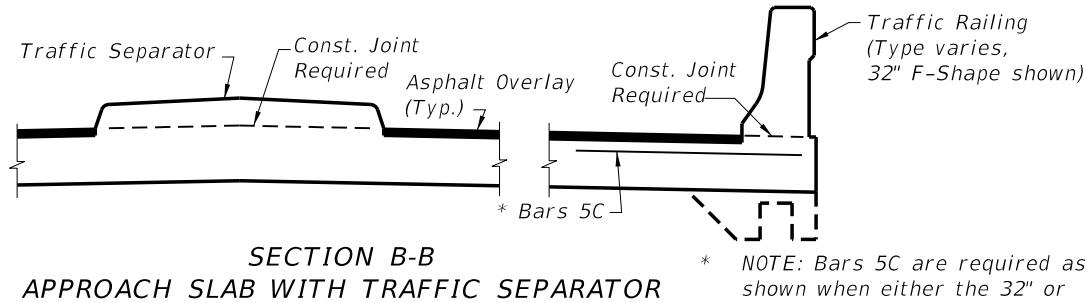
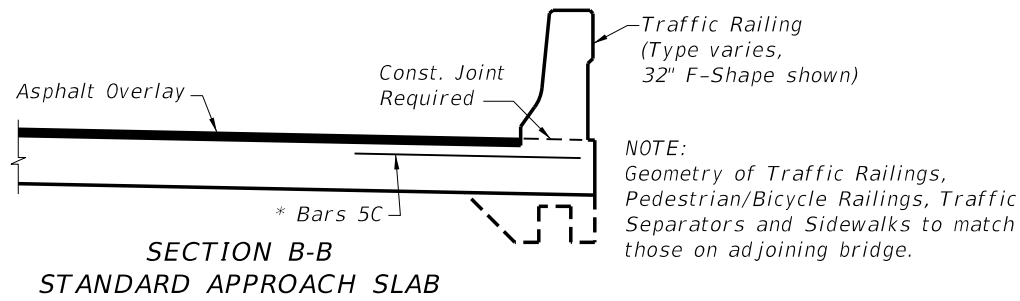

* NOTE: Bars 5C are required as shown when either the 32" or 42" F-Shape Traffic Railing or the Traffic Railing/Noise Wall are used at the edge of the Approach Slab.

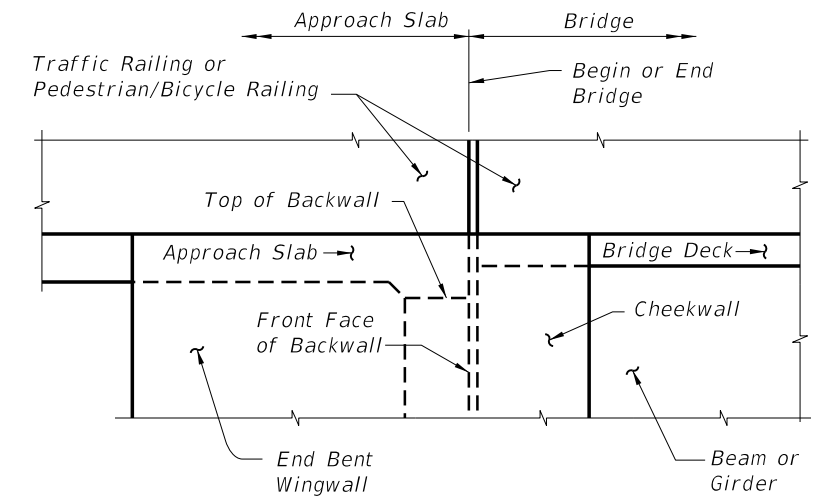
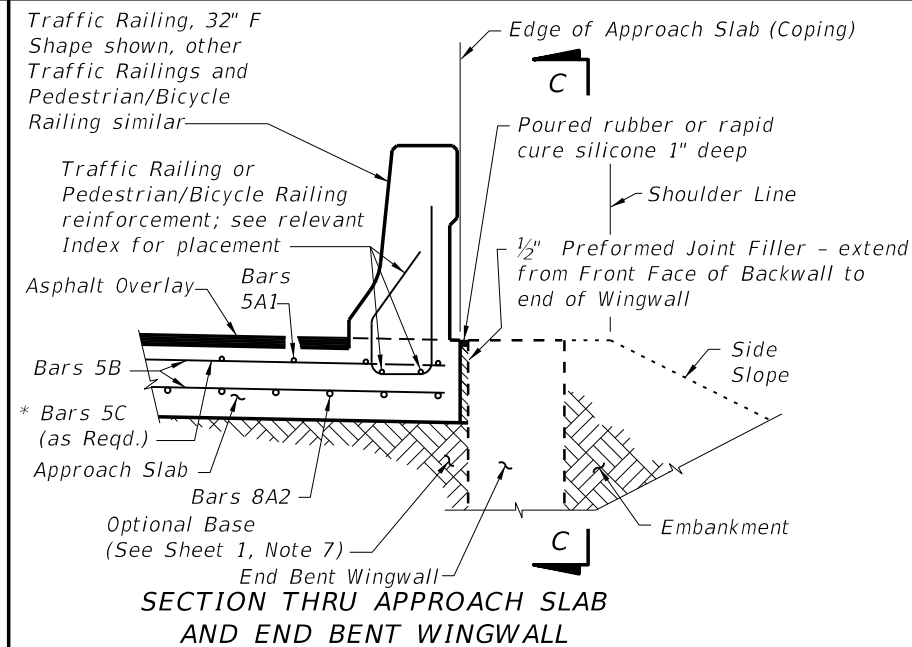
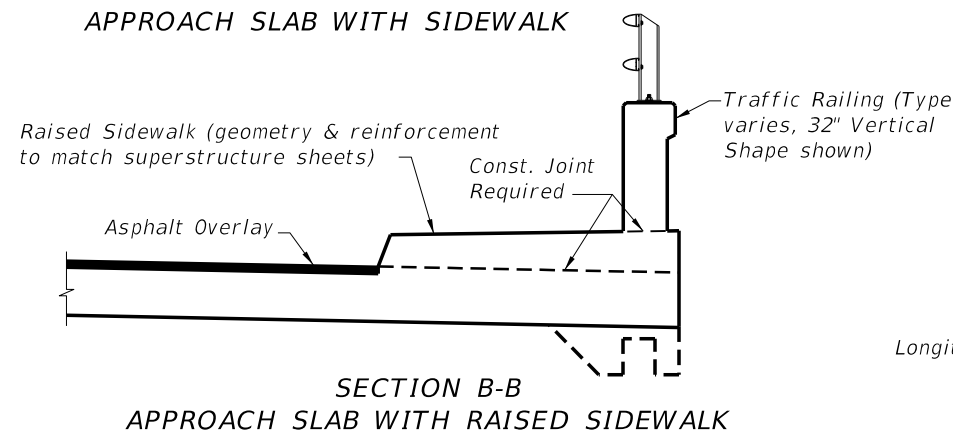
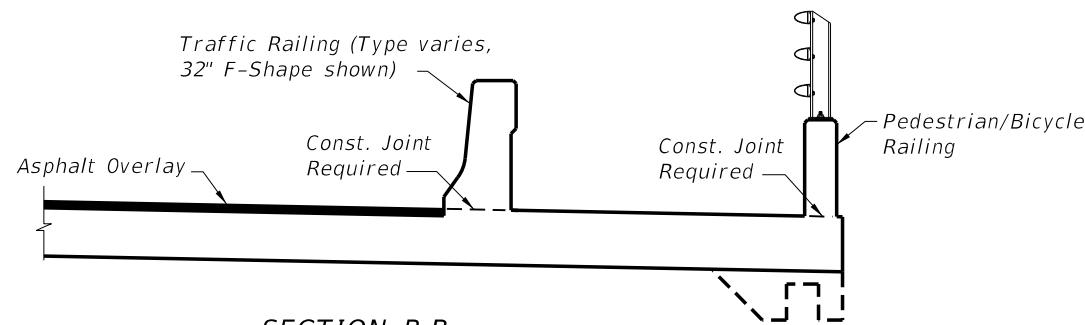
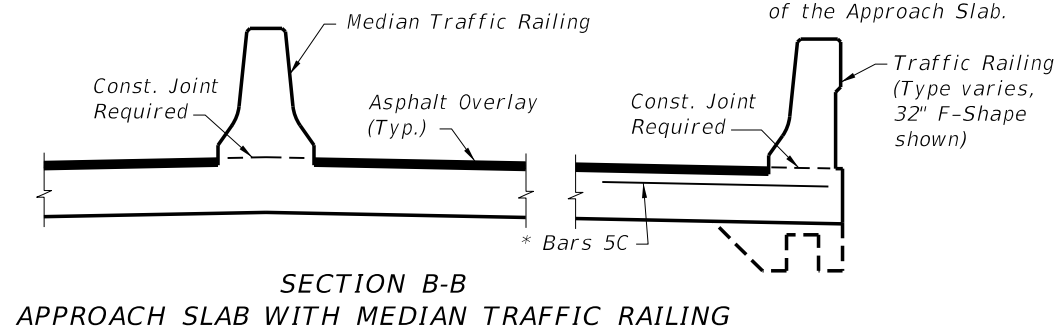

APPROACH SLAB WITH WINGWALL DETAILS

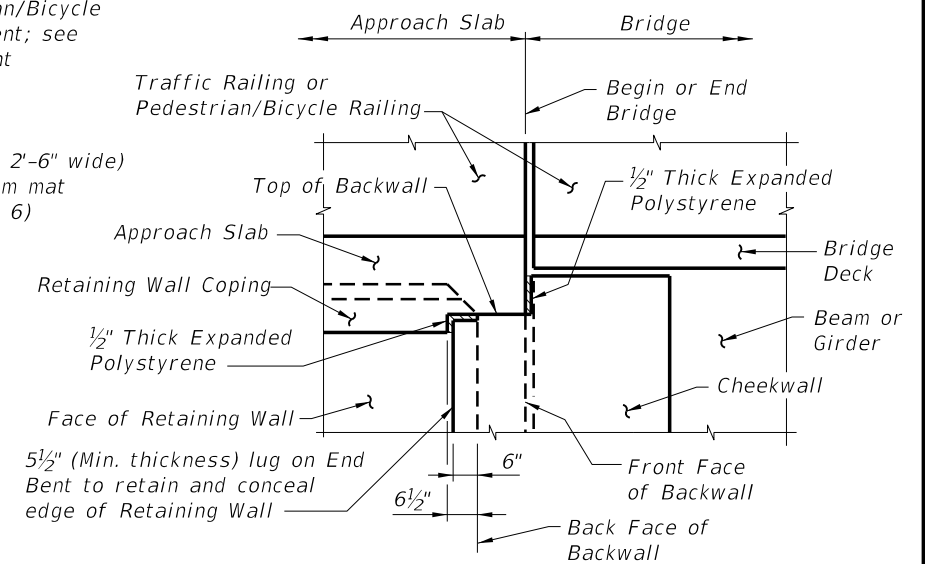
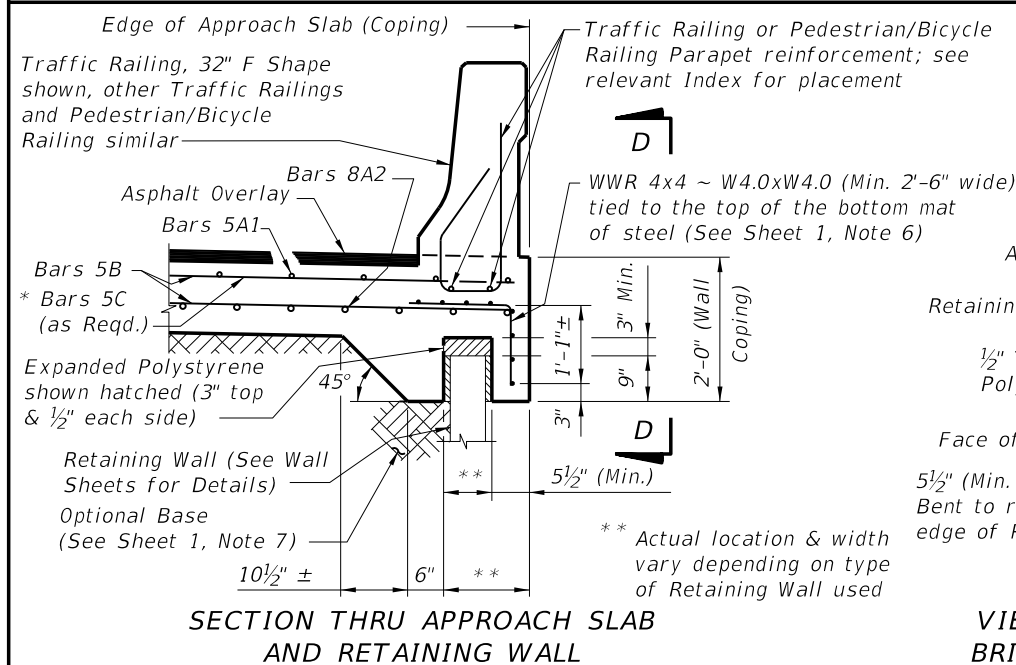

APPROACH SLAB WITH RETAINING WALL DETAILS

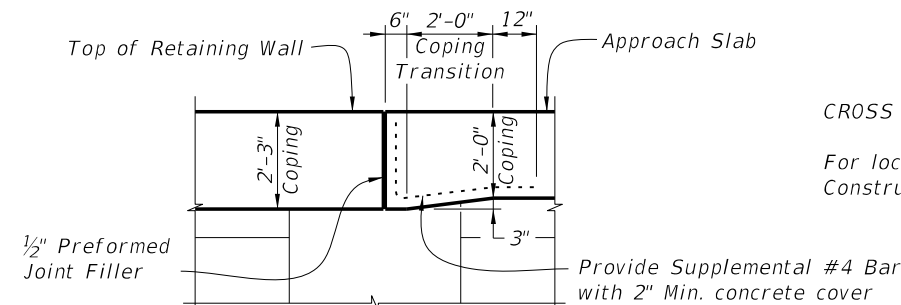
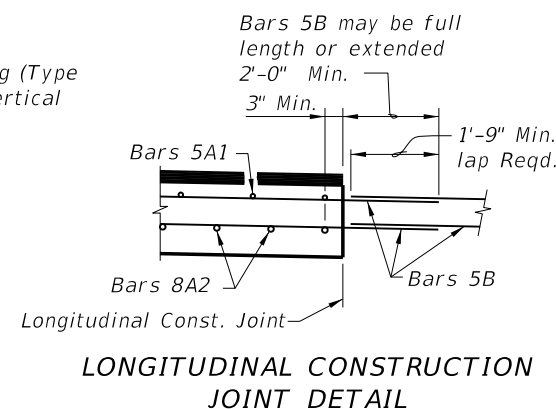

COPING TRANSITION DETAIL FOR
RETAINING WALLS WITH 2'-3" COPING HEIGHT
(Railing Not Shown For Clarity)

5/22/2014 1:55:03 PM

LAST REVISION 07/01/14	REVISION	DESCRIPTION:	 2015 DESIGN STANDARDS	APPROACH SLABS (FLEXIBLE PAVEMENT APPROACHES)	INDEX NO. 20900	SHEET NO. 2 of 2
---------------------------	----------	--------------	------------------------------	--	--------------------	---------------------