

* These dimensions are measured perpendicular to the end of beam

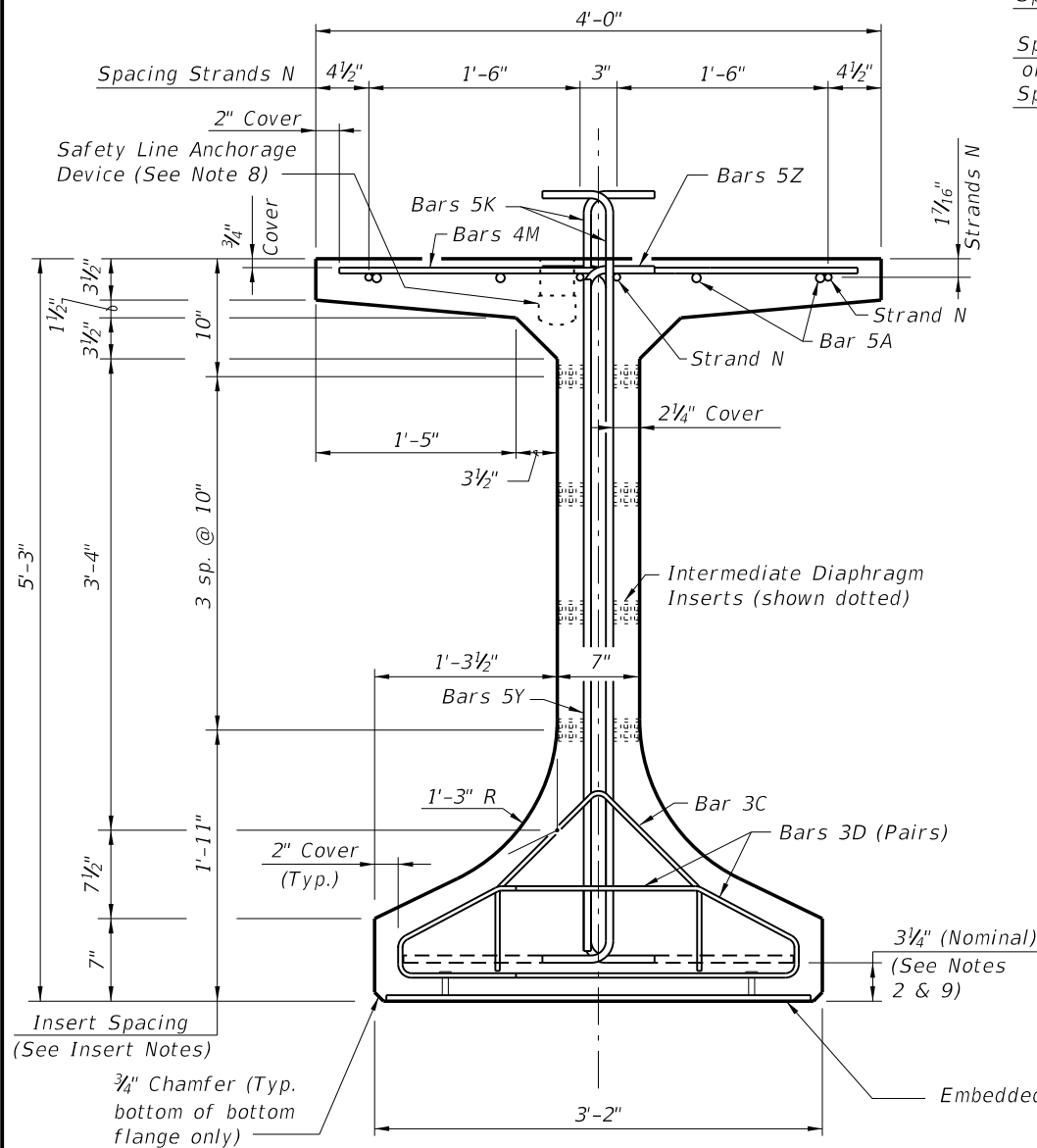

END VIEW

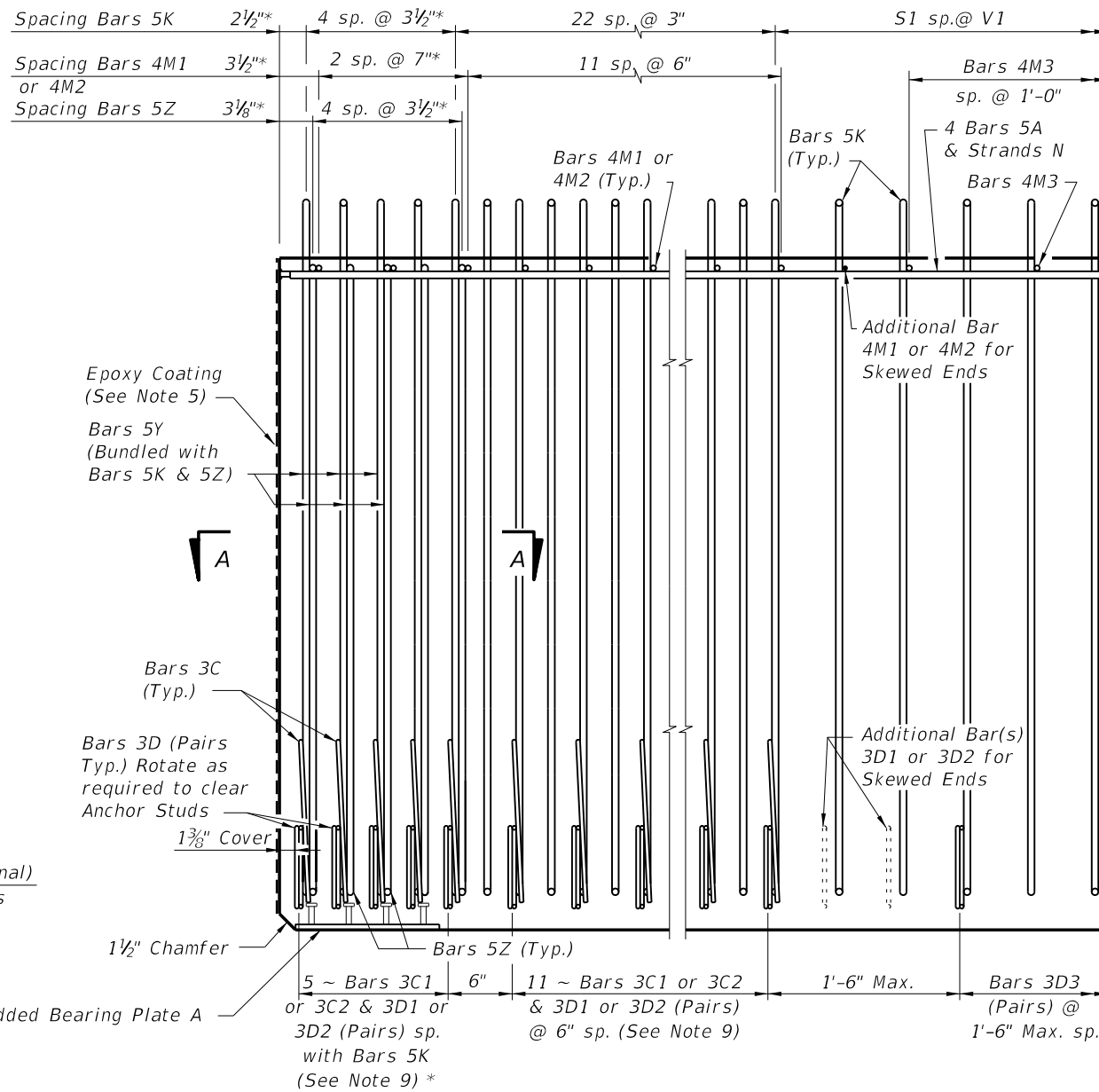

ELEVATION AT END OF BEAM
(Flanges Not Shown For Clarity)
(End 1 Shown, End 2 Similar)

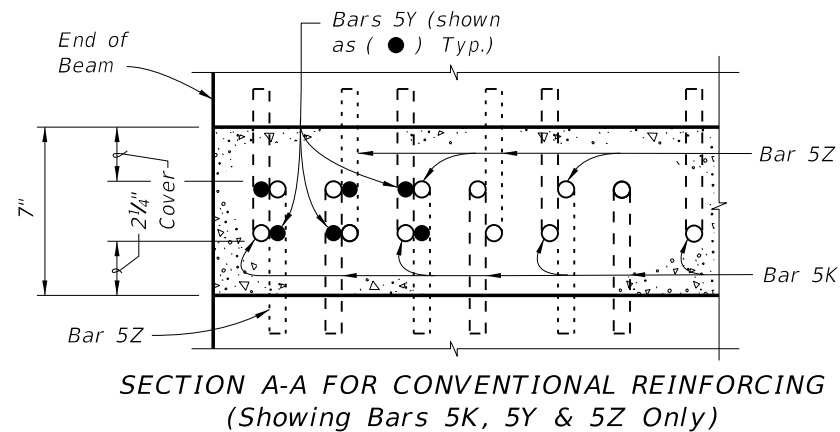

SECTION A-A FOR CONVENTIONAL REINFORCING
(Showing Bars 5K, 5Y & 5Z Only)

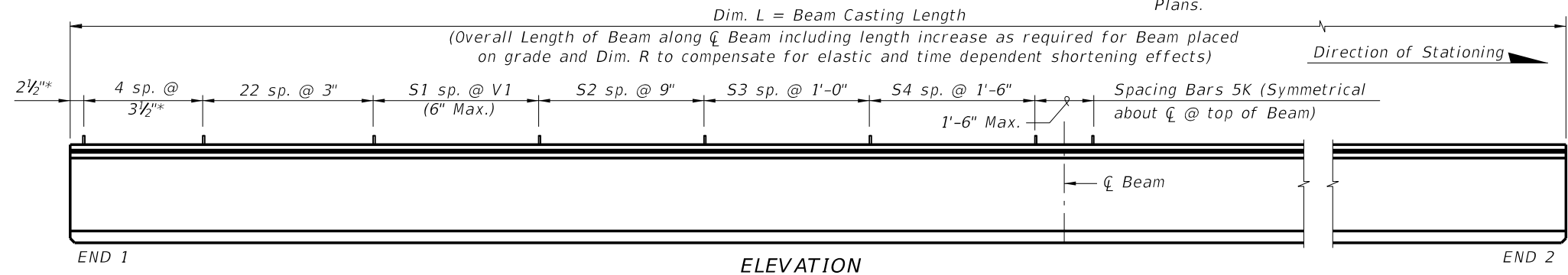

CONVENTIONAL REINFORCING
BAR BENDING DETAILS

BILL OF REINFORCING STEEL

MARK	NOTE NUMBERS	SIZE	NUMBER REQUIRED	LENGTH (NOTE 1)
A	—	5	8	24'-0"
C1	9, 10 & 11	3	16 (End 1)	Varies
C2	9, 10 & 11	3	16 (End 2)	Varies
D1	9, 10, 11 & 14	3	32 (End 1)	Varies
D2	9, 10, 11 & 14	3	32 (End 2)	Varies
D3	9 & 14	3	See Table	4'-3"
K	2, 9, 11 & 13	5	See Table	6'-5"
M1	9 & 10	4	14 (End 1)	Varies
M2	9 & 10	4	14 (End 2)	Varies
M3	9	4	See Table	3'-8"
N	3 & 4	3/8" Ø Strand	4	Dim. L
Y	9 & 11	5	12	4'-9"
Z	2, 9, 11 & 13	5	10	5'-11"

BENDING DIAGRAMS (See Note 1)

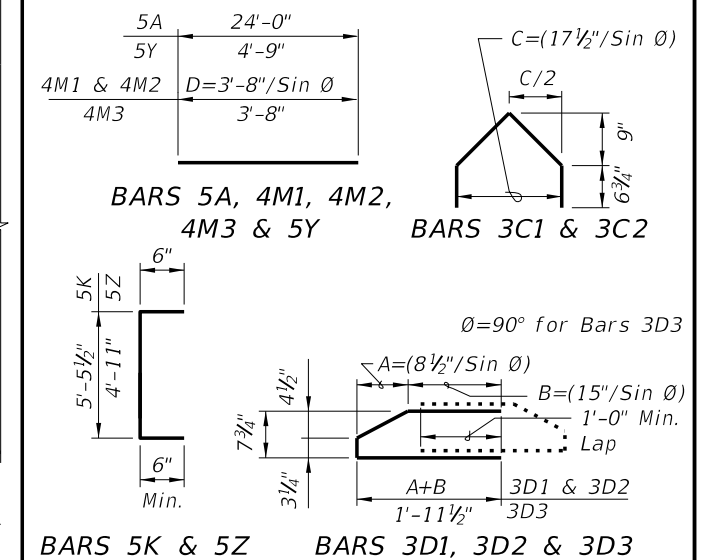

- NOTES:
- A. Work this Index with Index No. 20010 - Typical Florida-I Beam Details and Notes and the Florida-I Beam - Table of Beam Variables in Structures Plans.
 - B. For referenced notes, see Index No. 20010.
 - C. For Dimensions A, B, C, D, L, R & V1 and number of spaces S1 thru S4, see Florida-I Beam - Table of Beam Variables in Structures Plans.

5/22/2014 1:11:10 PM

ALTERNATE REINFORCING STEEL (WELDED WIRE REINFORCEMENT) DETAILS

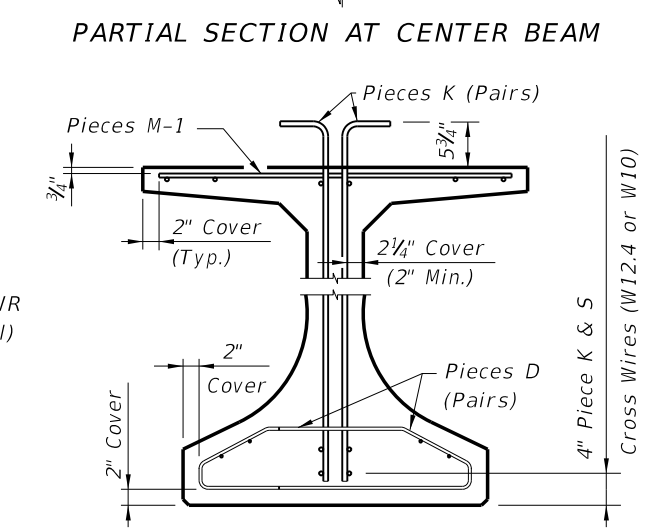
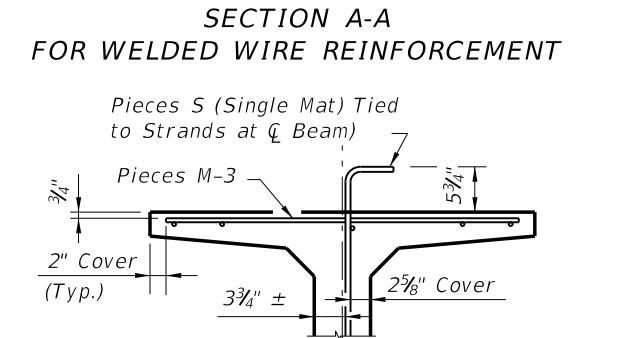
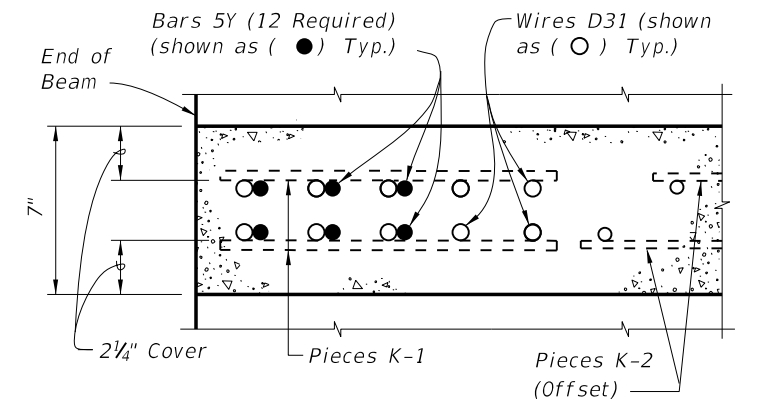
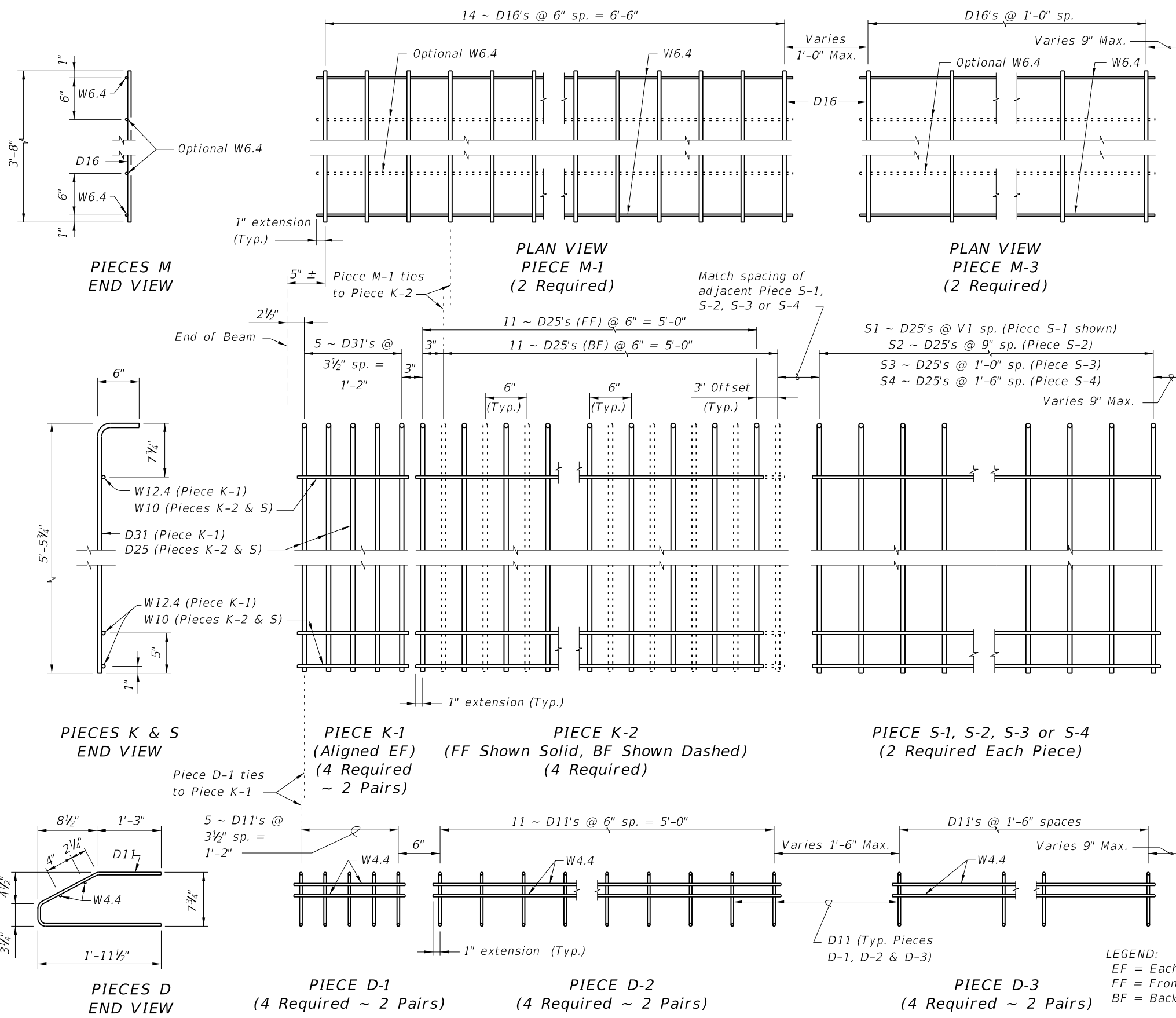

NOTES:
 a. See Sheet 1 for placement details & Table of Beam Variables in Structures Plans for variables S1, S2, S3, S4 & V1.
 b. Place Conventional Reinforcing Bars 5A & 3C as shown on Sheet 1. Place additional Bars 5Y as shown in Section A-A for Welded Wire Reinforcement. Bars 5Z will not be used with the WWR Option.
 c. Pieces may be fabricated in multiple length sections.
 d. For beams with skewed end conditions, Pieces D-1, D-2 & M-1 shall not be used; Conventional Reinforcing Bars D1, D2, C1, C2, M1 & M2 shall be used. See Index No. 20010 Skew Details and Note 9 for placement details. Shift Pieces K & Bars 5Y to accommodate skewed end conditions and align with Bars C and D.

LEGEND:
 EF = Each Face
 FF = Front Face
 BF = Back Face

5/22/2014 1:11:11 PM

LAST REVISION 07/01/10	DESCRIPTION:	 2015 DESIGN STANDARDS	FLORIDA-I 63 BEAM - STANDARD DETAILS	INDEX NO. 20063	SHEET NO. 2 of 2
---------------------------	--------------	---------------------------	--------------------------------------	--------------------	---------------------