

GENERAL NOTES:

- For additional notes and for material specifications not given herein refer to FDOT Design Standards Index No. 11860.
- The foundations are based upon the following conservative soil criteria which cover the great majority of soil types found in Florida:
  - Classification = Cohesionless (Fine Sand)
  - Friction Angle = 30 Degrees (30°)
  - Unit Weight = 50 LBS./CU. FT. (Assumed Saturated)
- Design Wind Speed = 150 MPH
- Design Wind Pressure (Service) = 27.6 PSF
- See Index 11860 for material specifications.

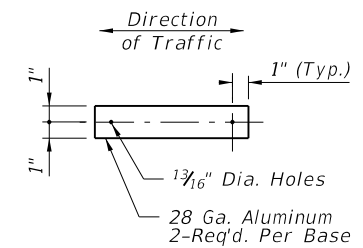
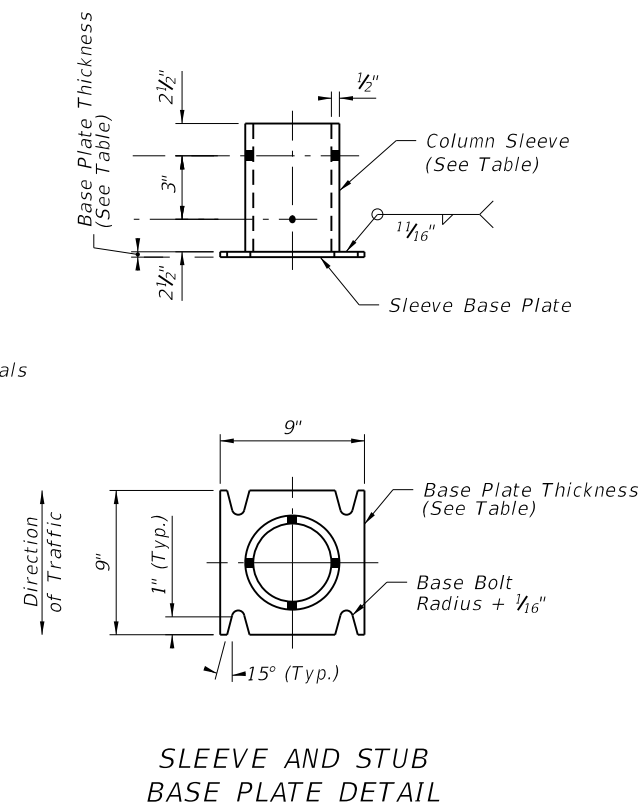
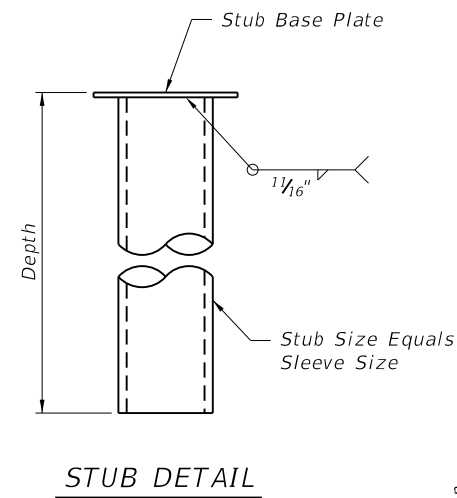
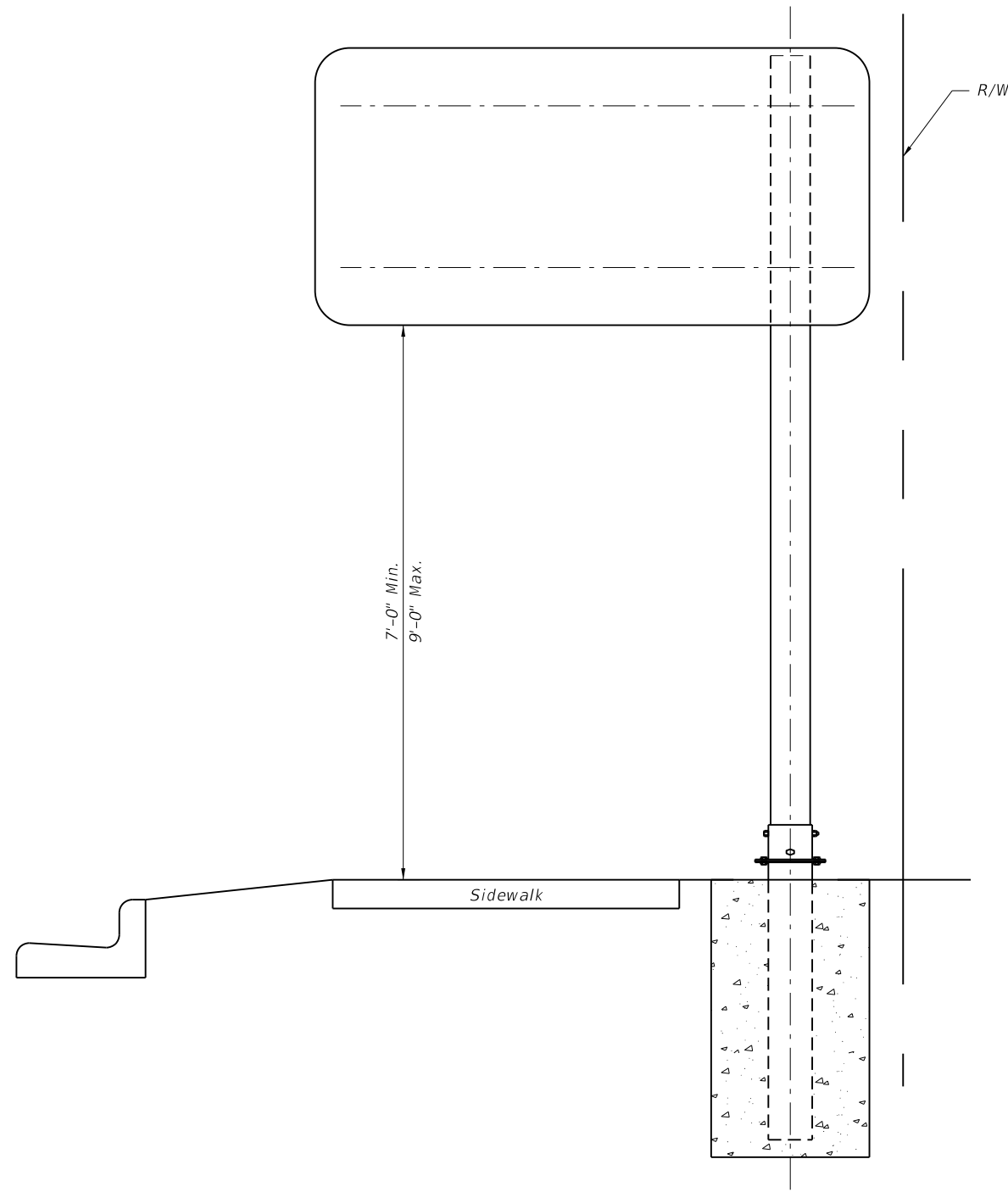

FOOTING SIZES (9' MAX. CLEAR COLUMN HEIGHT)	
SIGN SIZE	DEPTH
4'-0" x 5'-0"	6'-0"
4'-0" x 6'-0"	6'-0"
4'-0" x 7'-0"	6'-6"
4'-0" x 8'-0"	7'-0"

5/30/2014 12:36:28 PM

COLUMN SELECTION TABLE					
Sign Size Height (ft) x Length (ft)	Column Size Diameter (in) x Thickness (in)	Sleeve Size Diameter (in) x Thickness (in)	U-bolt Diameter (in)	Base Bolt Diameter (in) x Length (in)	Base Plate Thickness (in)
4'-0" x 5'-0"	4.5" x 0.337"	5.563" x 0.5"	1/2"	5/8" x 3 1/2"	1"
4'-0" x 6'-0"	(Schedule 80)	(Schedule 120)			
4'-0" x 7'-0"	5.563" x 0.375"	6.625" x 0.432"	5/8"	3/4" x 4"	1 1/8"
4'-0" x 8'-0"	(Schedule 80)	(Schedule 80)			

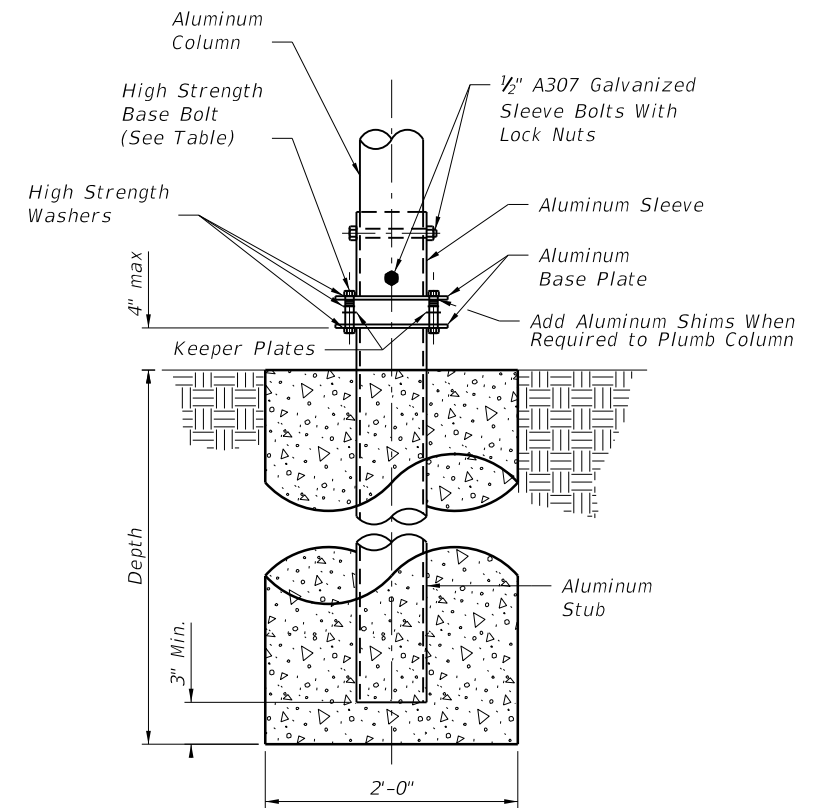
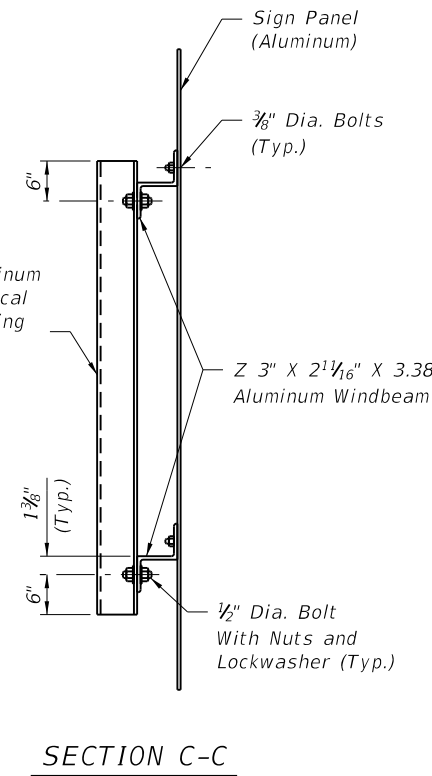
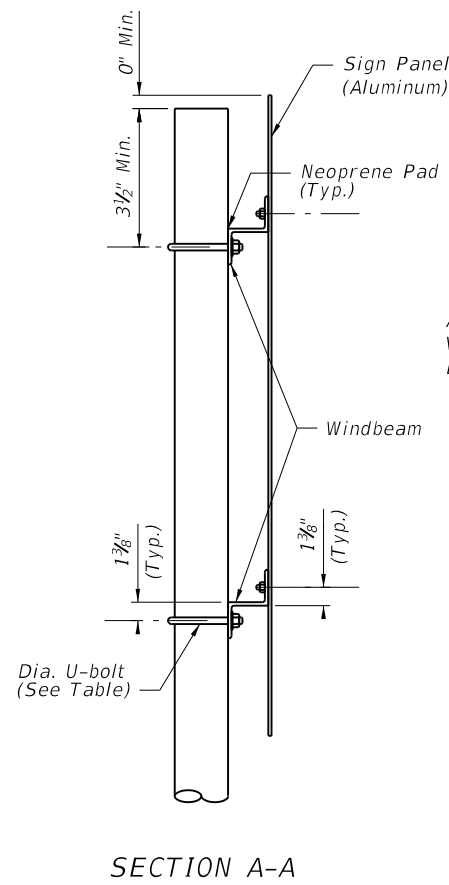
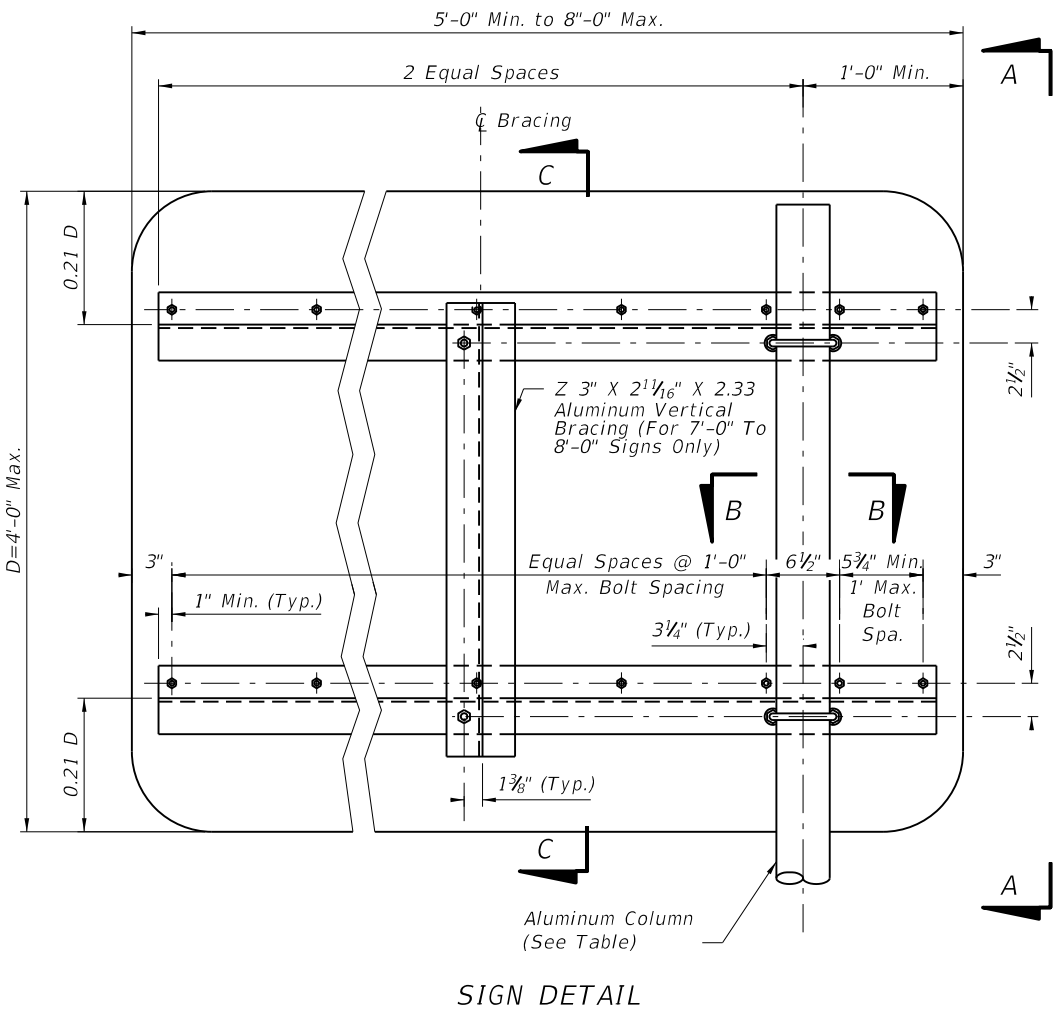

BASE AND FOUNDATION DETAIL

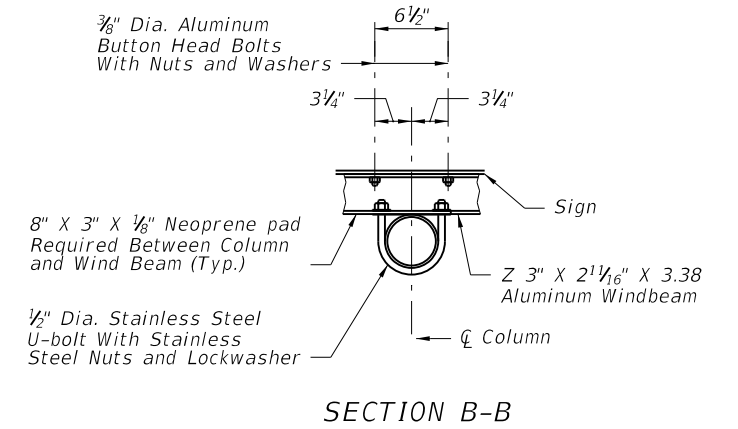

SECTION B-B

5/30/2014 12:36:29 PM