

**CANTILEVER SIGN STRUCTURE NOTES**

1. Design according to FDOT Structures Manual. Alternate Designs are not allowed.
2. Submit shop drawings for all work. Include:
  - a. Field verification of all upright heights.
  - b. Foundation elevations necessary to insure minimum vertical clearances as per traffic plans.
  - c. Anchor bolt orientation with respect to centerline of truss and the direction of traffic.
  - d. Show chord splices a minimum distance of 2 truss panel lengths apart. "SD" Panel from upright is the closest panel in which a chord splice may be used. See plans for Cantilever Sign Structure Data Table. Upright splices are not allowed.
3. Shop Fabrication, Assembly, Handling and Shipping:
  - a. Do not begin fabrication before receiving shop drawing approval.
  - b. Welding: Conform to American Welding Society Structural Welding Code (Steel) ANSI/AWS D1. 1 (current edition).
  - c. Shop assemble the entire structure after galvanizing and prior to shipment.
  - d. If necessary, disassemble and secure components for shipment.
4. Sign Structure Materials:
  - a. Upright and Chords (Steel Pipe): API -5L-X42, 42 ksi yield or ASTM A500, Grade B (min.).
  - b. Steel Angles: ASTM A 709, Grade 36.
  - c. Steel Plates: ASTM A 709, Grade 36.
  - d. Weld Metal: E70XX.
  - e. Bolts: ASTM A325 Type 1, (install per Specification Section 700) with single, self-locking nuts.
  - f. Anchor Bolts: ASTM F1554, Grade 55 with ASTM A563 Grade A heavy-hex double nuts.
  - g. Install all nuts per manufacturer's instructions.
  - h. Bolt hole diameters: equal to the bolt diameter plus 1/16".
  - i. Anchor bolt hole diameters: equal to the bolt diameter plus 1/2".
  - j. Use of split lock washers is not permitted.
5. Galvanization; Nuts, bolts and washers: ASTM F2329. Other steel items: ASTM A123
6. Sign Panels: Aluminum. See Elevation drawing for sizes and locations.
7. Foundation Materials:
  - a. Reinforcing Steel: ASTM A615, Grade 60.
  - b. Concrete: Class IV, minimum 5.5 ksi compressive strength at 28-days for all environmental classifications for Spread Footing.  
Class IV (Drilled Shaft), minimum 4.0 ksi compressive strength at 28-days for all environmental classifications for Drilled Shaft.
8. Construct the Sign Structure foundation in accordance with FDOT Specification Section 455.
9. Prior to erection, record the as-built anchor locations and provide to the Engineer.
10. After placement of the upright and prior to installation of the truss, adjust the leveling nuts beneath the base plate to achieve the back rake shown on the Camber Diagram.
11. Place backfill above the footing prior to installation of the sign panels. Do not remove or reduce in height without prior approval of the Engineer.
12. Install sign panels as shown on the Elevation drawing.
13. Verify CSL access tubes will not interfere with anchor bolt installation before excavating the shaft. When CSL access tube locations conflict with anchor bolt locations, move the CSL access tube location ± two inches along the inner circumference of the reinforcing cage. Notify the Engineer before excavating the shaft if the CSL access tube locations cannot be moved out of conflict with anchor bolt locations.
14. Handhole at pole base is required for DMS Structures. See Index 18300 for details.

\* NOTE: Contractor shall verify these Dimensions prior to Fabrication of Upright.

NOTE: See Plans for Cantilever Sign Structure Data Table.

6/24/2014 2:15:10 PM

LAST REVISION 07/01/14	REVISION	DESCRIPTION:	 <b>2015 DESIGN STANDARDS</b>	<b>CANTILEVER SIGN STRUCTURE</b>	INDEX NO. <b>11310</b>	SHEET NO. <b>1 of 5</b>
---------------------------	----------	--------------	--	----------------------------------	---------------------------	----------------------------

Directions of Travel

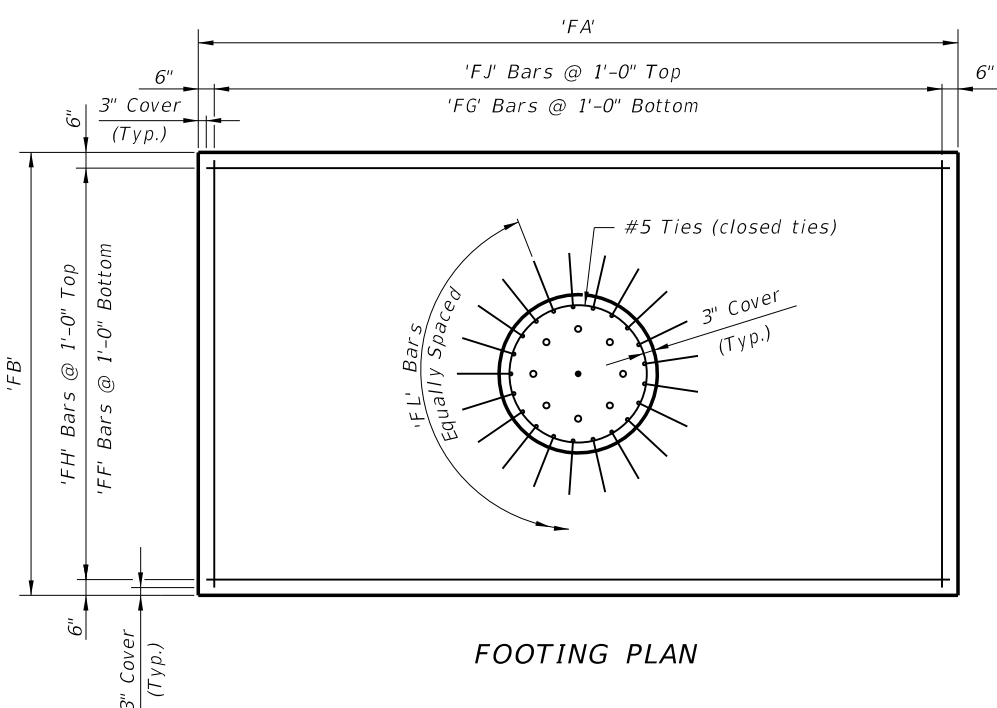

FOOTING PLAN

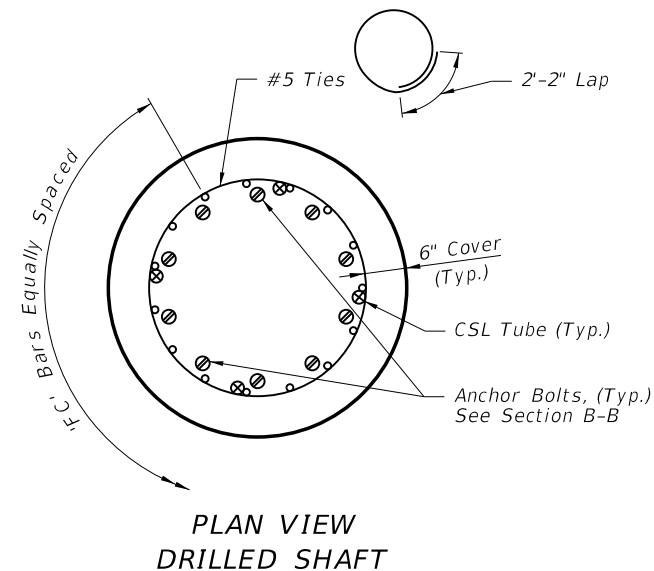

PLAN VIEW DRILLED SHAFT

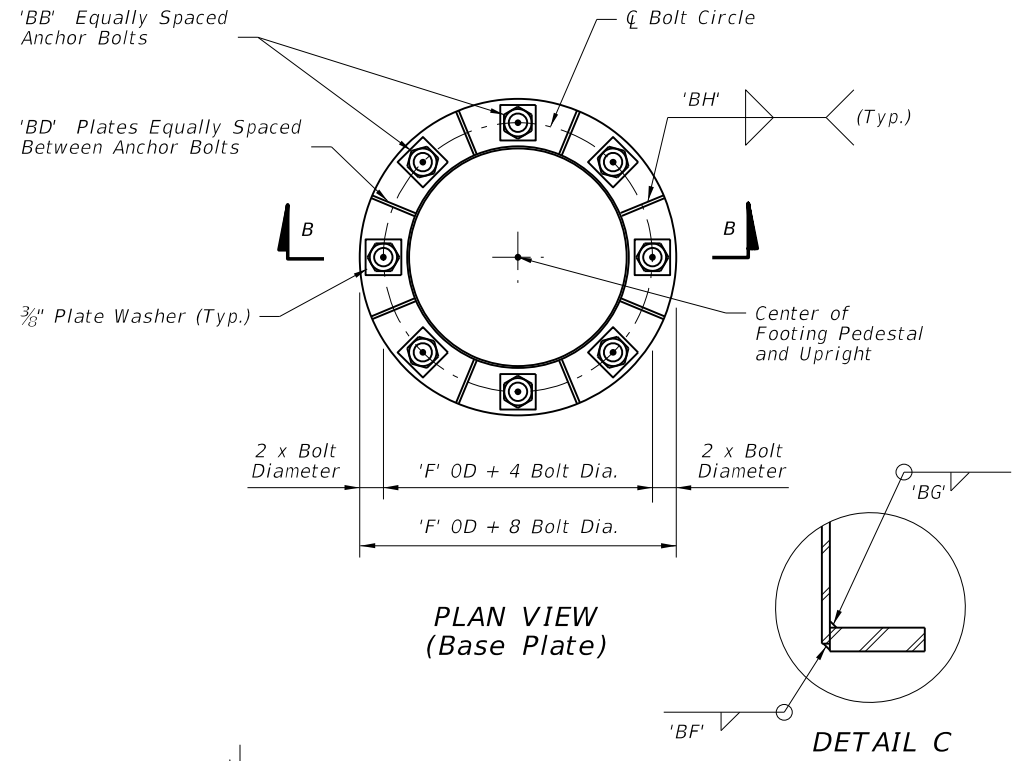

PLAN VIEW (Base Plate)

DETAIL C

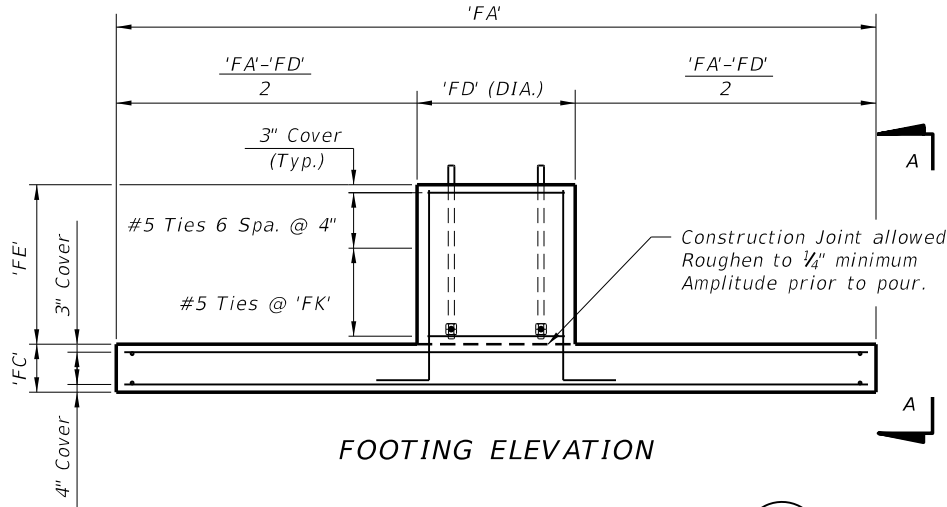

FOOTING ELEVATION

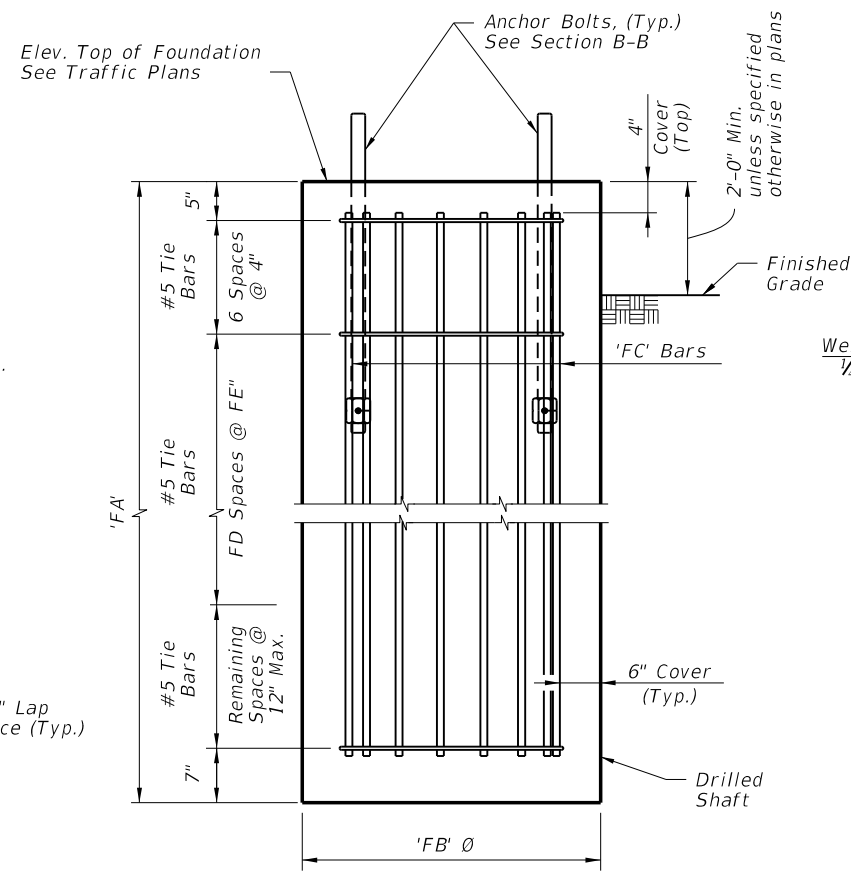

ELEVATION DRILLED SHAFT (Alternate Foundation)

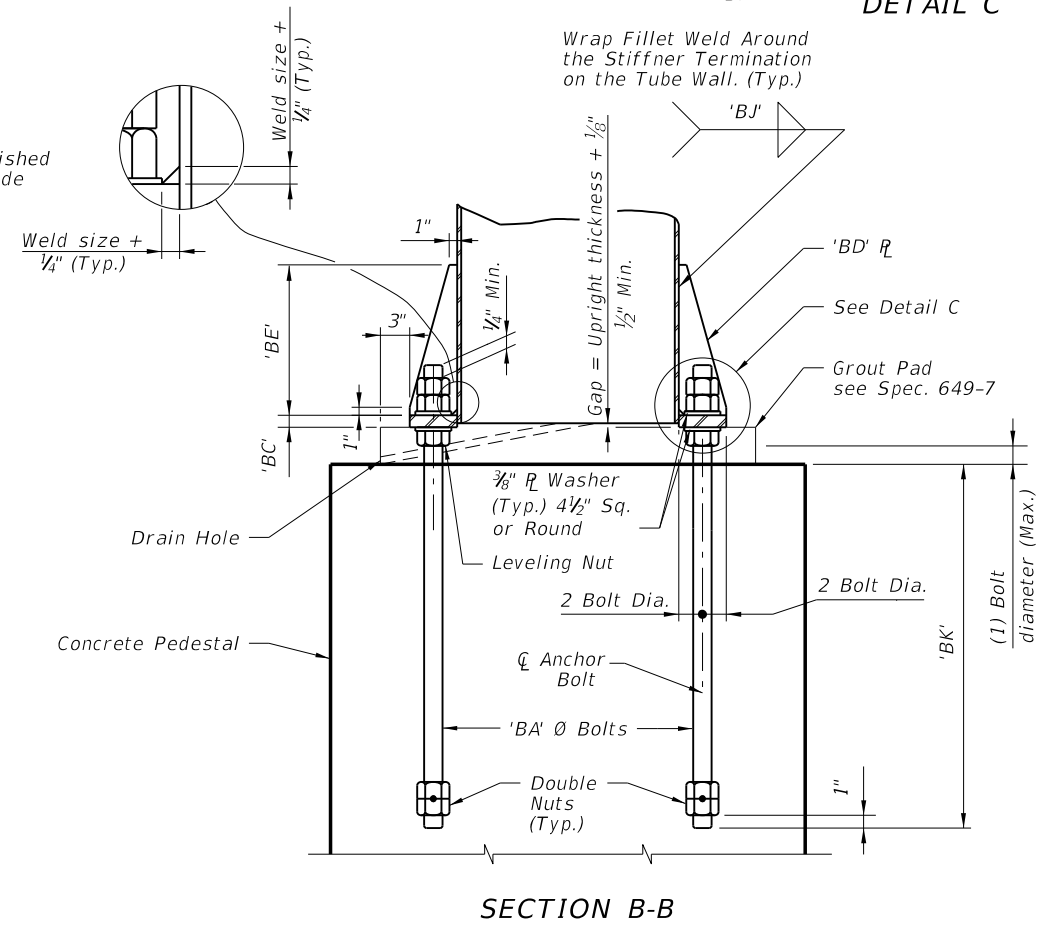

SECTION B-B

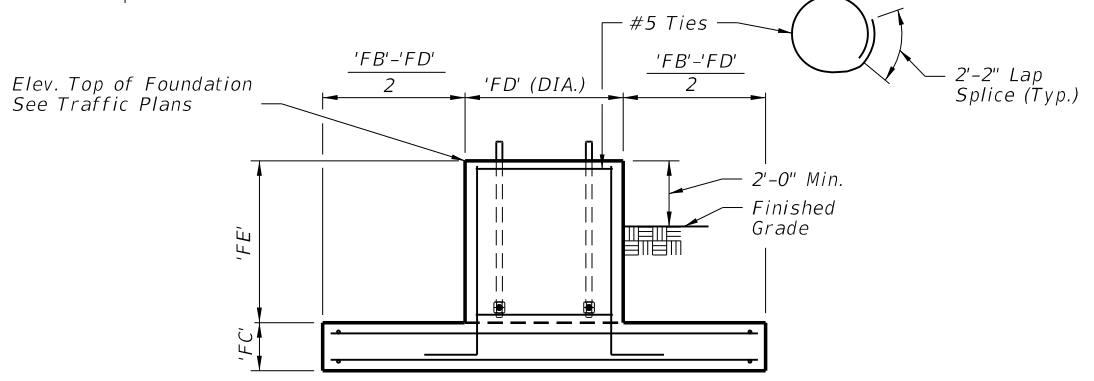

VIEW A-A

6/24/2014 2:15:11 PM

LAST REVISION	07/01/14	DESCRIPTION:	<b>2015 DESIGN STANDARDS</b>	<b>CANTILEVER SIGN STRUCTURE</b>	INDEX NO. <b>11310</b>	SHEET NO. <b>2 of 5</b>
---------------	----------	--------------	------------------------------	----------------------------------	---------------------------	----------------------------

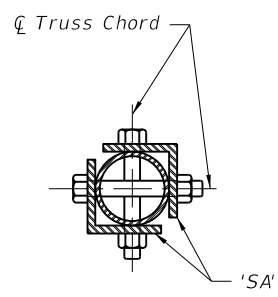

SECTION D-D

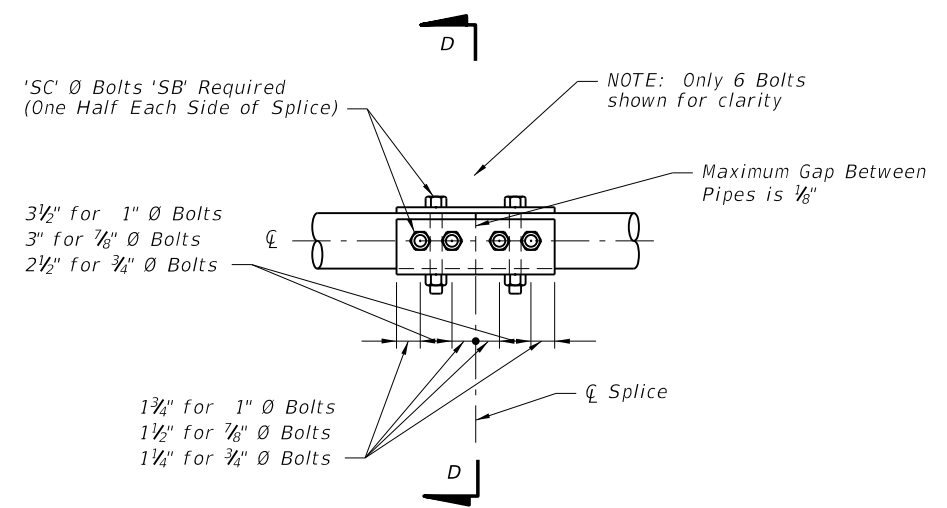

SPLICE CONNECTION DETAIL  
 (Splice not allowed for trusses  $\leq 40'$   
 Splice optional for trusses  $> 40'$ )

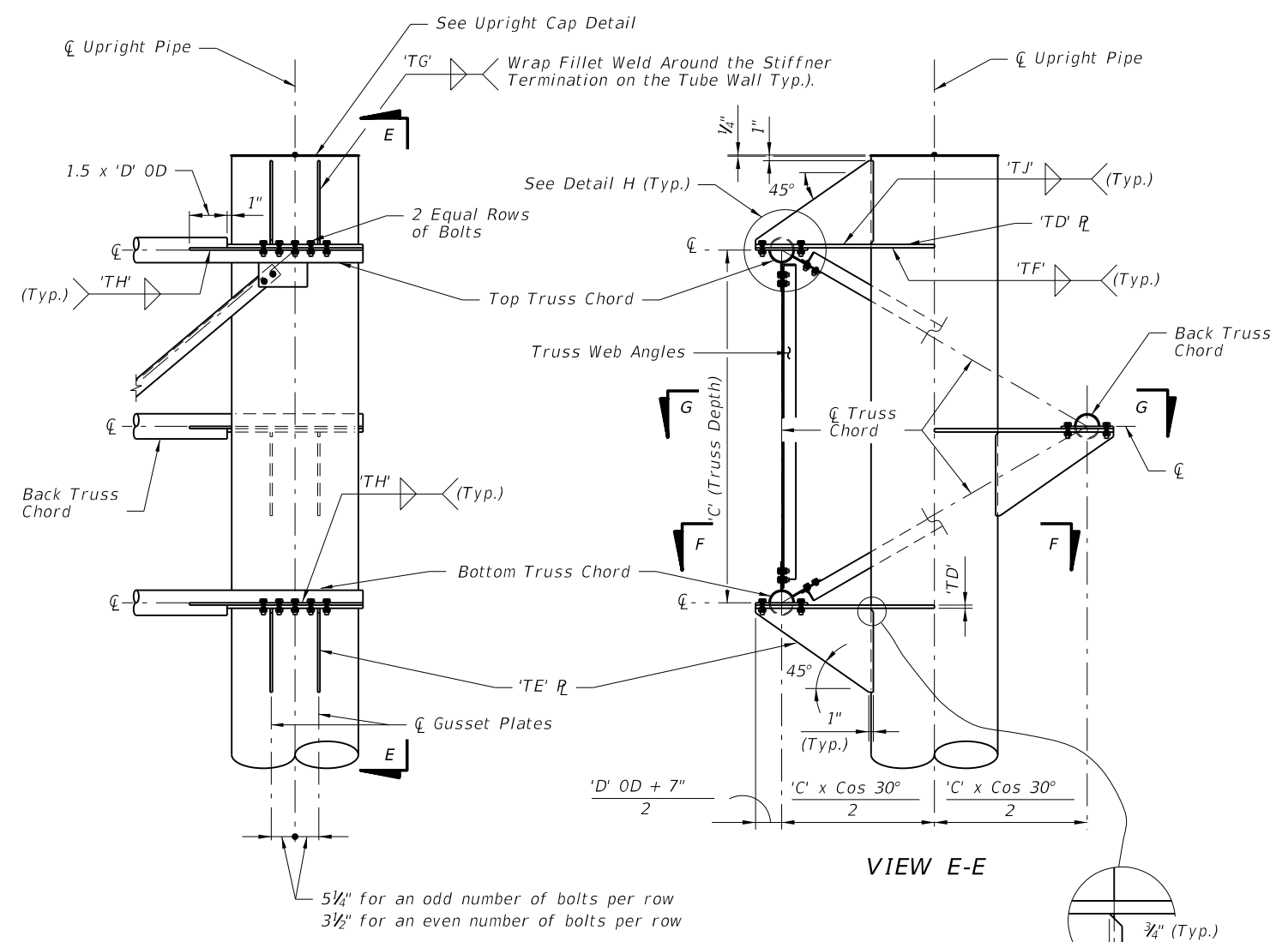

UPRIGHT-TRUSS CONNECTION DETAIL  
 (Web Members from back Truss Chord omitted for clarity)

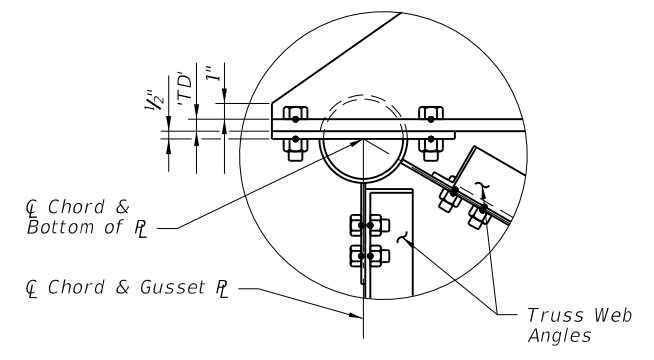

DETAIL H

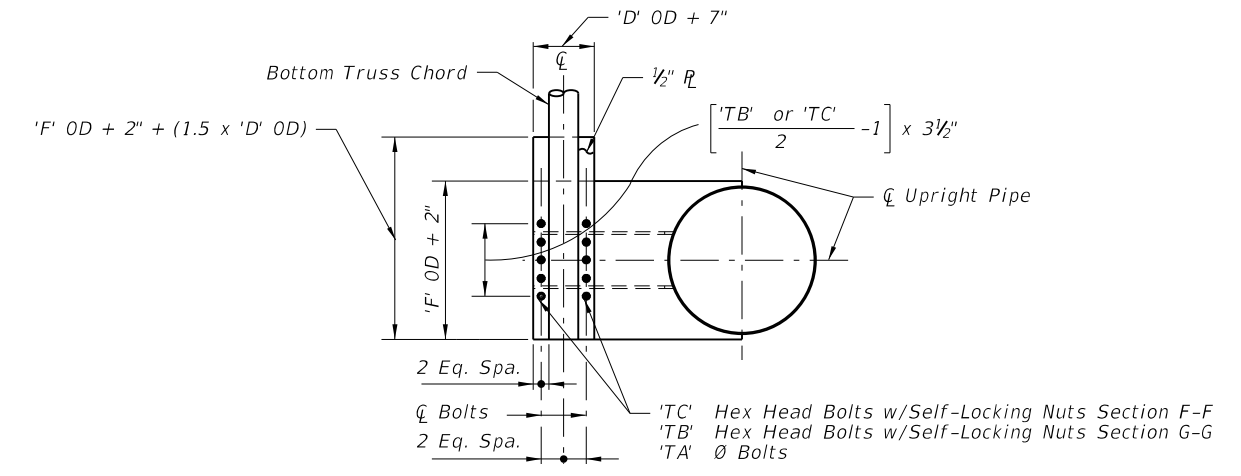

SECTION F-F, SECTION G-G SIMILAR  
 (With Gusset Plate & Angles omitted for clarity)

NOTE:  
 Abbreviation  
 OD ~ Outside Diameter

6/24/2014 2:15:12 PM

LAST REVISION 07/01/14	REVISION	DESCRIPTION:	 2015 DESIGN STANDARDS	CANTILEVER SIGN STRUCTURE	INDEX NO. 11310	SHEET NO. 3 of 5
---------------------------	----------	--------------	------------------------------	---------------------------	--------------------	---------------------

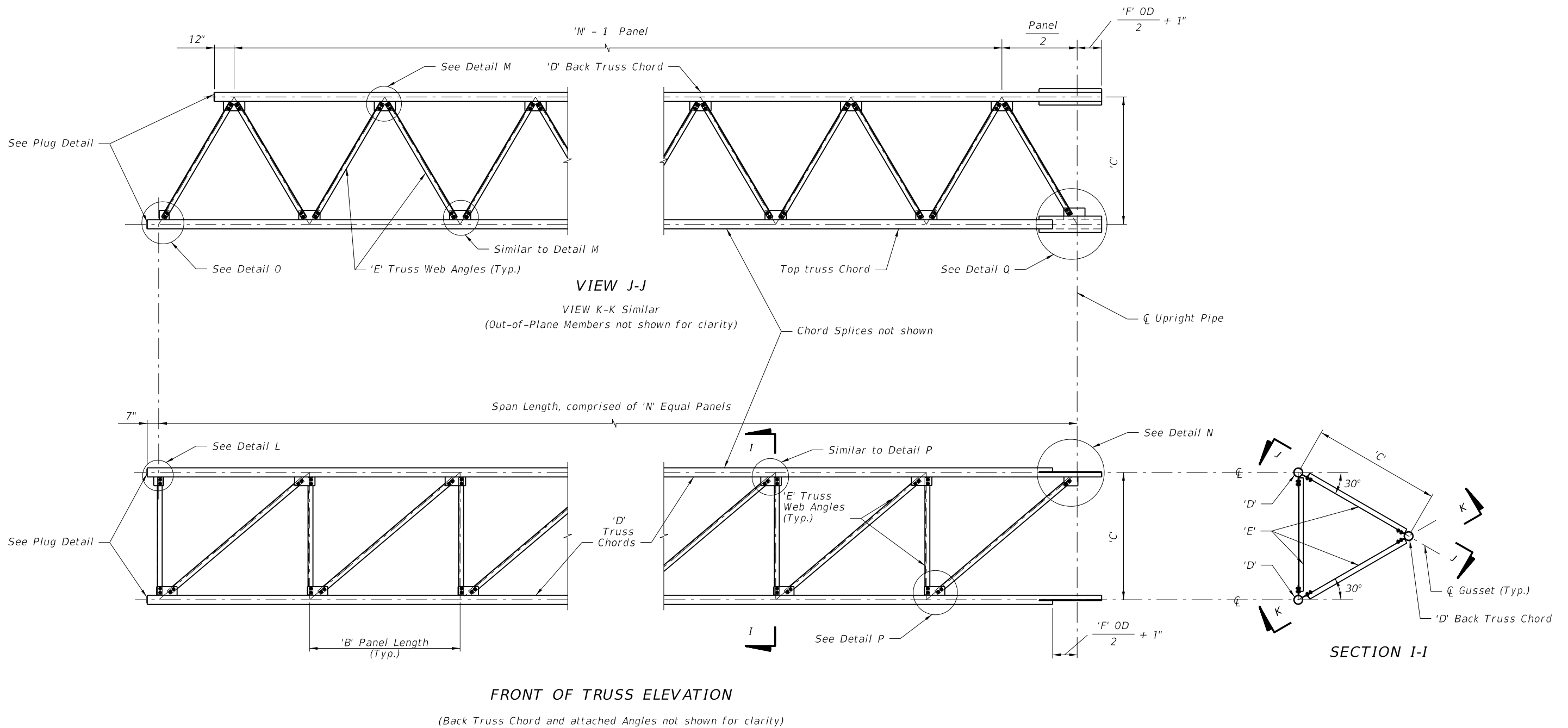

NOTE:  
Abbreviation  
OD ~ Outside Diameter

6/24/2014 2:15:13 PM

LAST REVISION 07/01/05	REVISION	DESCRIPTION:	 2015 <b>DESIGN STANDARDS</b>	<b>CANTILEVER SIGN STRUCTURE</b>	INDEX NO. <b>11310</b>	SHEET NO. <b>4 of 5</b>
------------------------------	----------	--------------	-------------------------------------	----------------------------------	------------------------------	-------------------------------

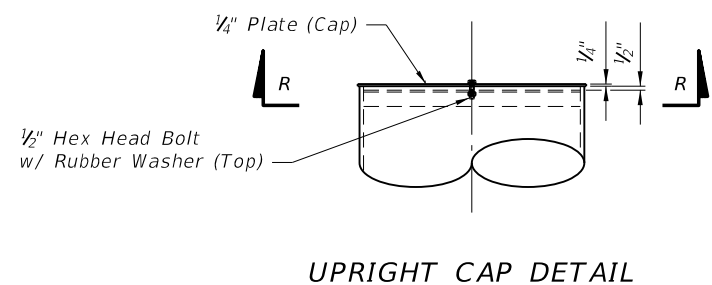
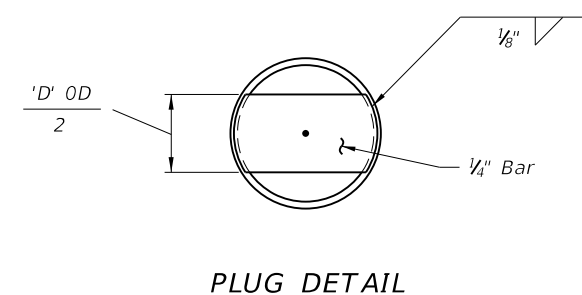
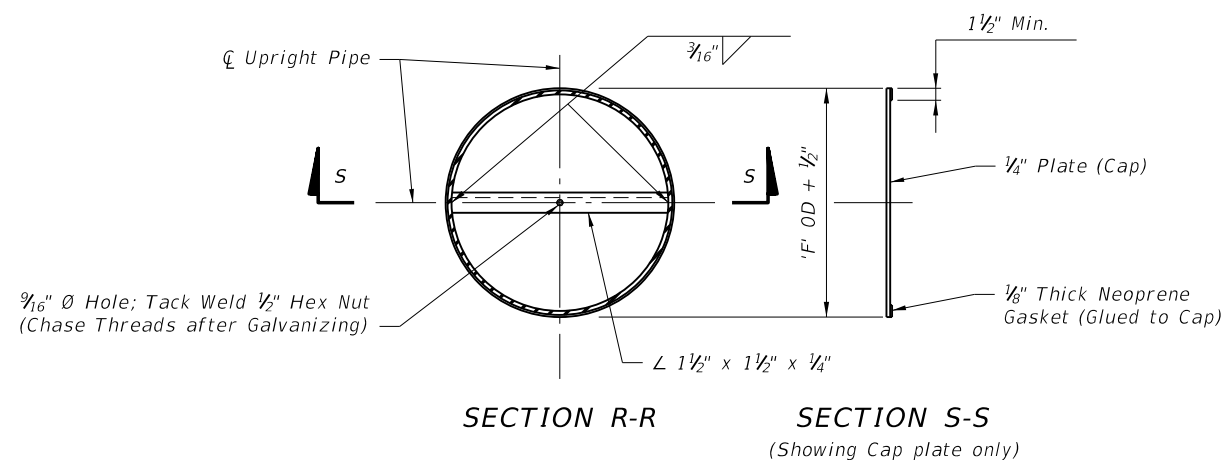
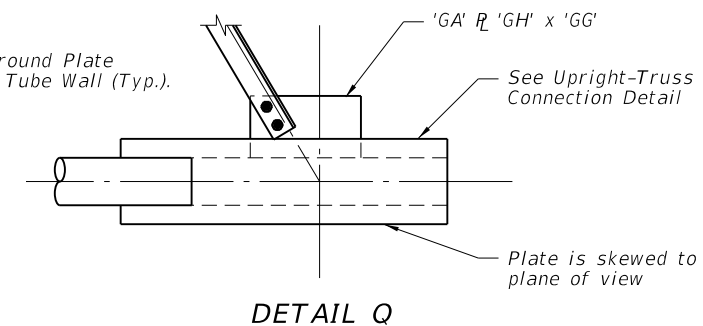
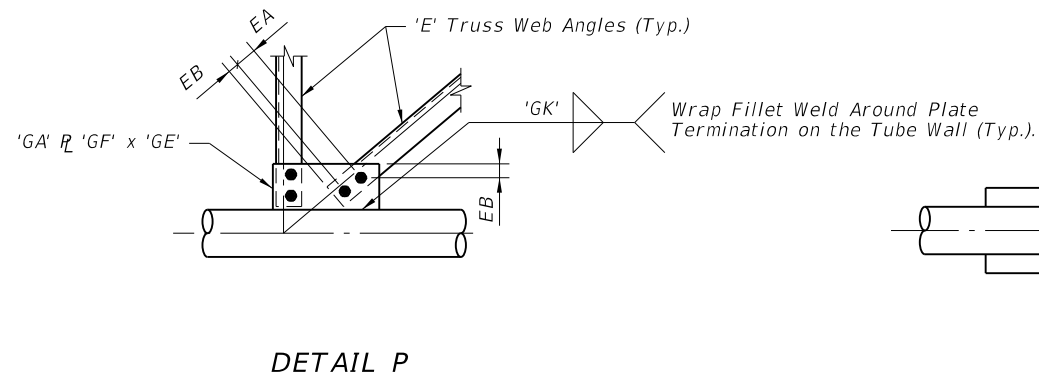
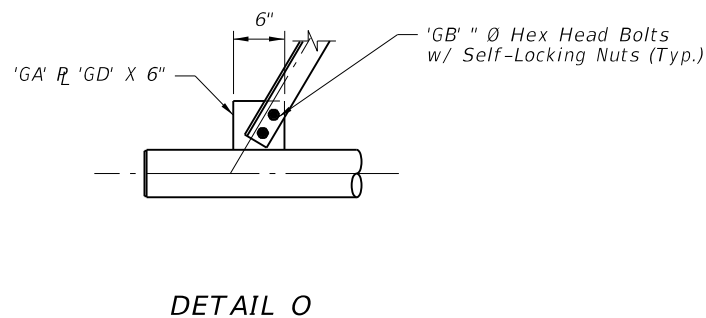
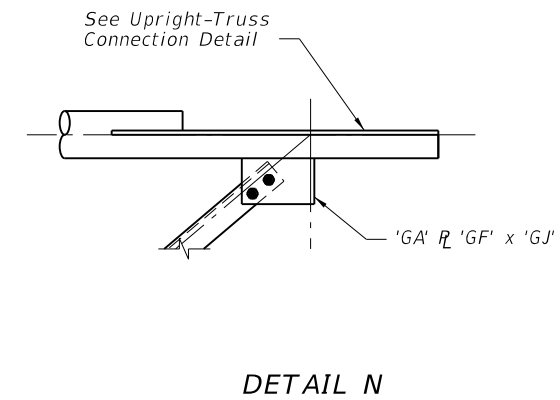
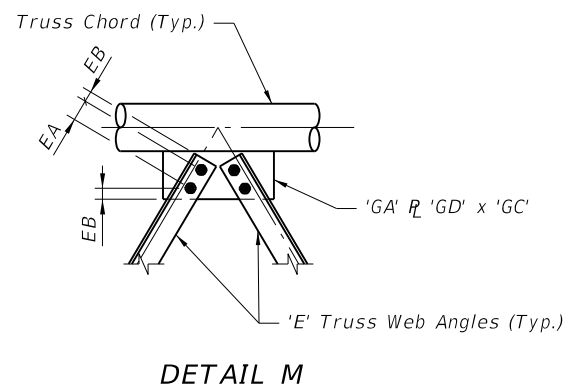
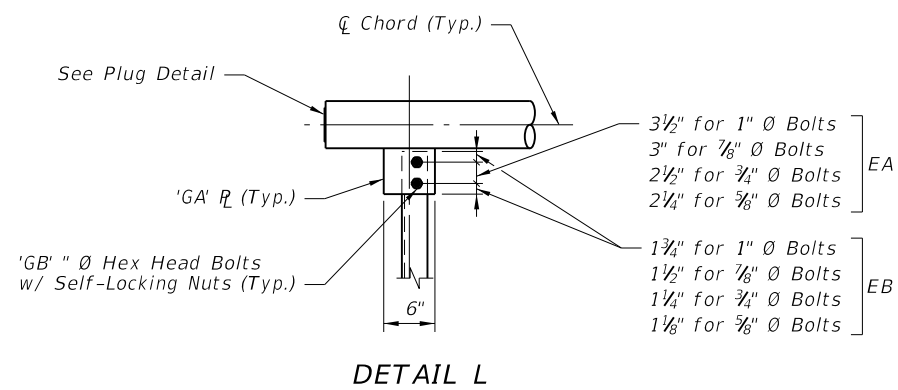

NOTE:  
Abbreviation  
OD ~ Outside Diameter

6/24/2014 2:15:13 PM

LAST REVISION 07/01/14	REVISION	DESCRIPTION:	 <b>2015 DESIGN STANDARDS</b>	<b>CANTILEVER SIGN STRUCTURE</b>	INDEX NO. <b>11310</b>	SHEET NO. <b>5 of 5</b>
---------------------------	----------	--------------	--	----------------------------------	---------------------------	----------------------------