

TYPICAL ELEVATION

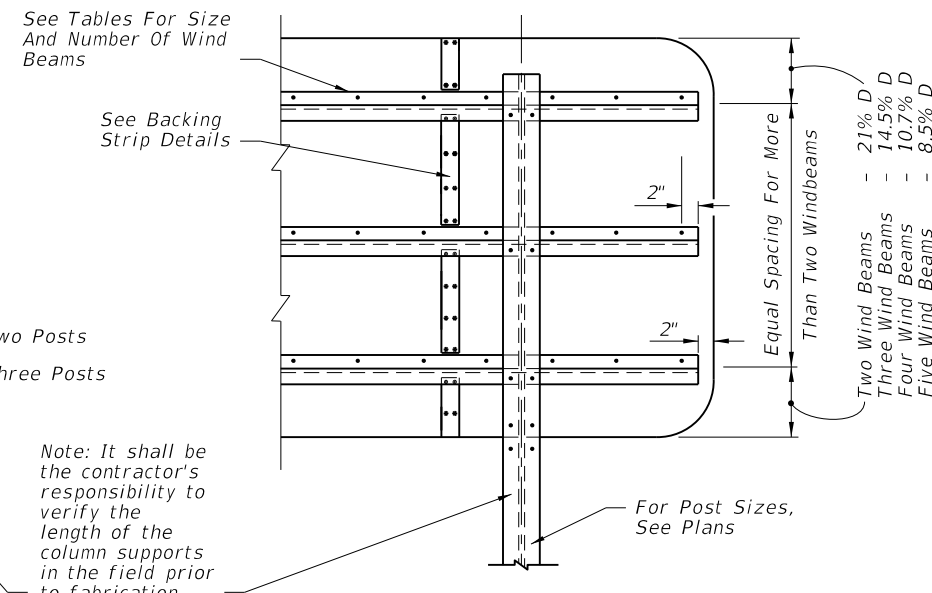

PARTIAL REAR ELEVATION

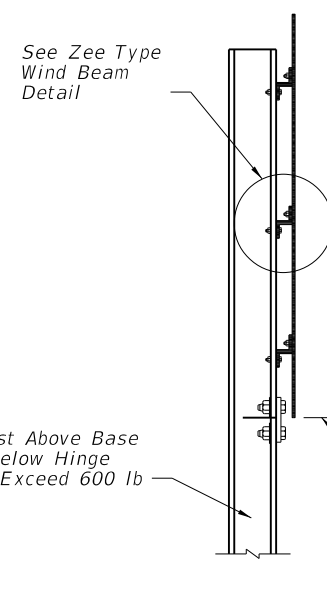

SIDE VIEW

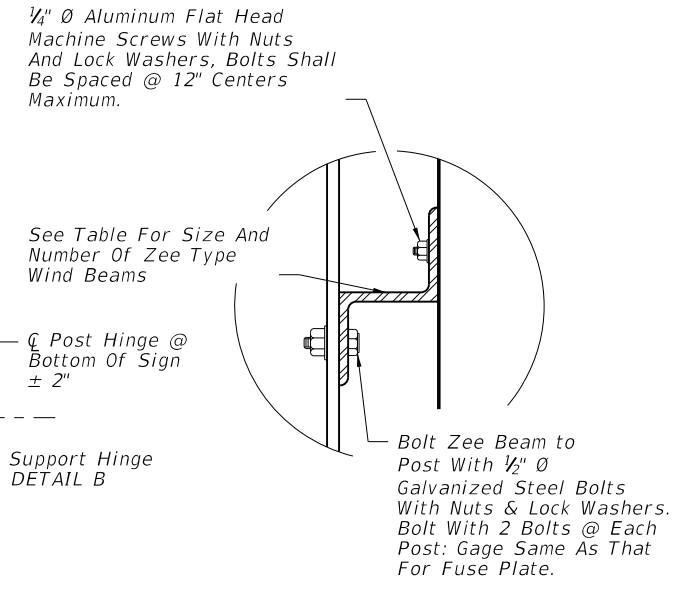

ZEE TYPE WIND BEAM

Note: If the sign panels are deeper than 10', a Horizontal Panel Splice is allowed at an interior Zee Beam, shop drawings shall be required.

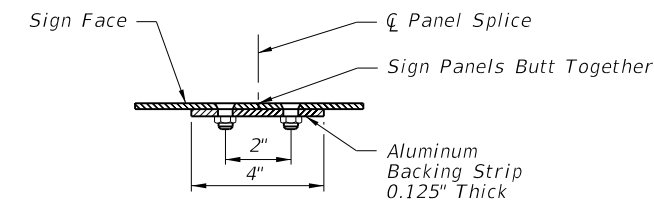

BACKING STRIP DETAILS

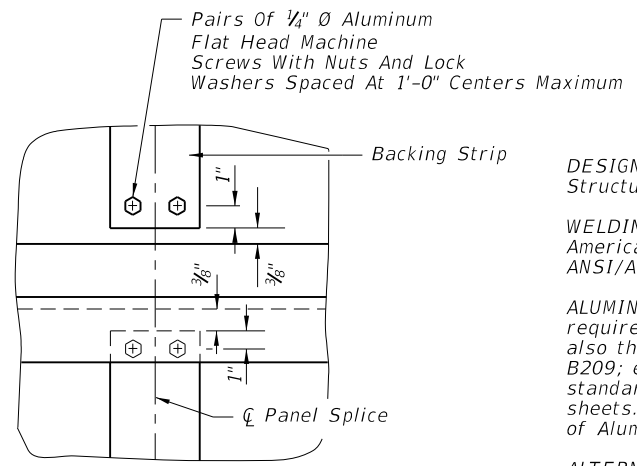

GENERAL NOTES

DESIGN SPECIFICATIONS: Design according to FDOT Structures Manual (current edition).

WELDING: Perform all welding in accordance with the American Welding Society Structural welding code (Steel), ANSI/AWS D1-1 current edition.

ALUMINUM MATERIALS: All aluminum materials shall meet the requirements of the Aluminum Association's Alloy 6061-T6 and also the following ASTM specifications: Sheets and plates, B209; extruded tube, bars, rods & shapes, B221; and standard structural shapes, B308. No stenciling permitted on sheets. Aluminum welding rods shall meet the requirements of Aluminum Association Alloy No. 5556 filler wire.

ALTERNATE MATERIAL: Material meeting the requirements of Aluminum Association Alloy 6351-T5 and ASTM B221 may be used for extruded bars, rods, shapes and tubes.

SIGN FACE: All sign face corners shall be rounded.

STRUCTURAL STEEL: All structural steel shall meet the requirements of ASTM A36 and shall be galvanized in accordance with ASTM A123.

ALUMINUM BOLTS, NUTS, & LOCK WASHERS: Aluminum bolts shall meet the requirements of Aluminum Association Alloy 2024-T4 (ASTM F468). The bolts shall have an anodic coating at least 0.0002" thick and be Chromate sealed. Lock washers shall meet the requirements of Aluminum Association Alloy 7075-T6 (ASTM B221). Nuts shall meet the requirements of Aluminum Association Alloy 6061-T6 or 6262-T9 (ASTM F467).

STEEL BOLTS, NUTS, & WASHERS: All steel bolts, nuts and washers shall meet the requirements of ASTM A325 and shall be galvanized in accordance with ASTM F2329.

BASE CONNECTION: High strength bolts L_2 in the base connection shall be tightened only to the torque shown in the table on sheet 2 and 3. Overtightened base connections will not be permitted.

FUSE PLATE: All holes in fuse plates shall be drilled. All plate cuts shall, preferably, be saw cuts; however, flame cutting will be permitted provided all edges are round. Metal projecting beyond the plane of the plate face will not be permitted.

BRASS SHIM: Provide shim plate per ASTM B36.

SHOP DRAWINGS: When ground sign supports are fabricated in accordance with these plans no shop drawings are required. Shop drawings will be required for approval when the column length exceeds the length shown in the plans by more than 2'-0".

FABRICATOR NOTE: All bolts, except L_2 bolts and Zee Beam to post bolts, shall be tightened in accordance with Section 700 of the Specifications.

NUMBER OF WIND BEAMS FOR GIVEN DEPTH & WIND					
Wind	No. Beams	Max. Depth	Wind	No. Beams	Max. Depth
110	2	7'-0"	150	2	6'-0"
110	3	12'-0"	150	3	10'-4"
110	4	16'-4"	150	4	14'-0"
110	5	20'-8"	150	5	17'-8"
130	2	6'-8"			
130	3	11'-4"			
130	4	15'-4"			
130	5	19'-0"			

DESIGN WIND SPEEDS BY COUNTY

110 mph Alachua, Baker, Bradford, Clay, Columbia, Gadsden, Gilchrist, Hamilton, Hardee, Jackson, Jefferson, Lafayette, Lake, Leon, Madison, Marion, Polk, Putnam, Sumter, Suwannee, and Union Counties.

130 mph Bay, Brevard, Calhoun, Charlotte, Citrus, DeSoto, Dixie, Duval, Flagler, Franklin, Glades, Gulf, Hendry, Hernando, Highlands, Hillsborough, Holmes, Lee, Levy, Liberty, Manatee, Nassau, Okaloosa, Okeechobee, Orange, Osceola, Pasco, Pinellas, Sarasota, Seminole, St. Johns, Taylor, Volusia, Wakulla, Walton, and Washington Counties.

150 mph Broward, Collier, Escambia, Indian River, Martin, Miami-Dade, Monroe, Palm Beach, Santa Rosa, and St. Lucie Counties.

SIZE OF WIND BEAMS		
Size Of Zee*	Length Of Sign (Feet)	
	2 Posts	3 Posts
Zee 1.75 x 1.75 x 1.08	0 to 11'-0"	0 to 17'-4"
Zee 3 x 2.69 x 2.33	11'-1" to 19'-0"	17'-5" to 29'-6"
Zee 3 x 2.69 x 3.38	19'-1" to 20'-8"	29'-7" to 31'-6"

*Note: Zee Beams Are Aluminum - No Steel Equivalent Available Designation Gives (Member Depth) x (Flange=Width) x (lb/ft)

10:30:35 AM 7/1/2014

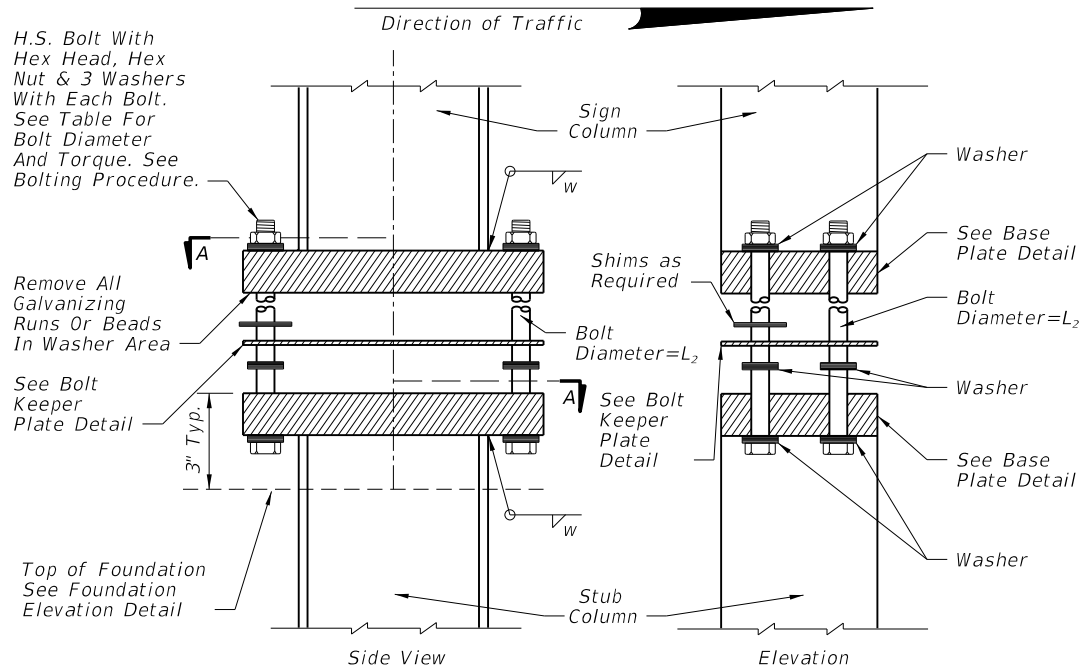

SIGN COLUMN & STUB COLUMN VIEWS
BASE CONNECTION

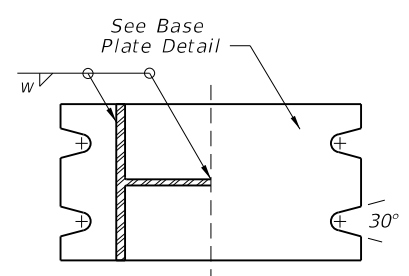

SECTION A-A

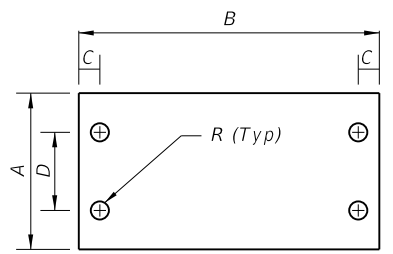

BOLT KEEPER PLATE

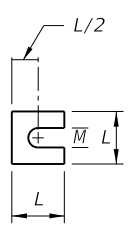

SHIM DETAIL

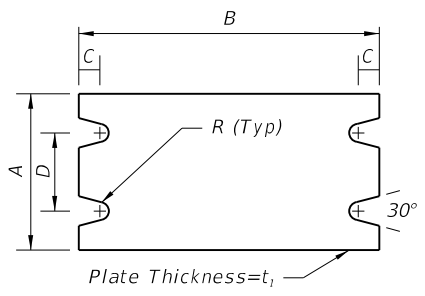

BASE PLATE

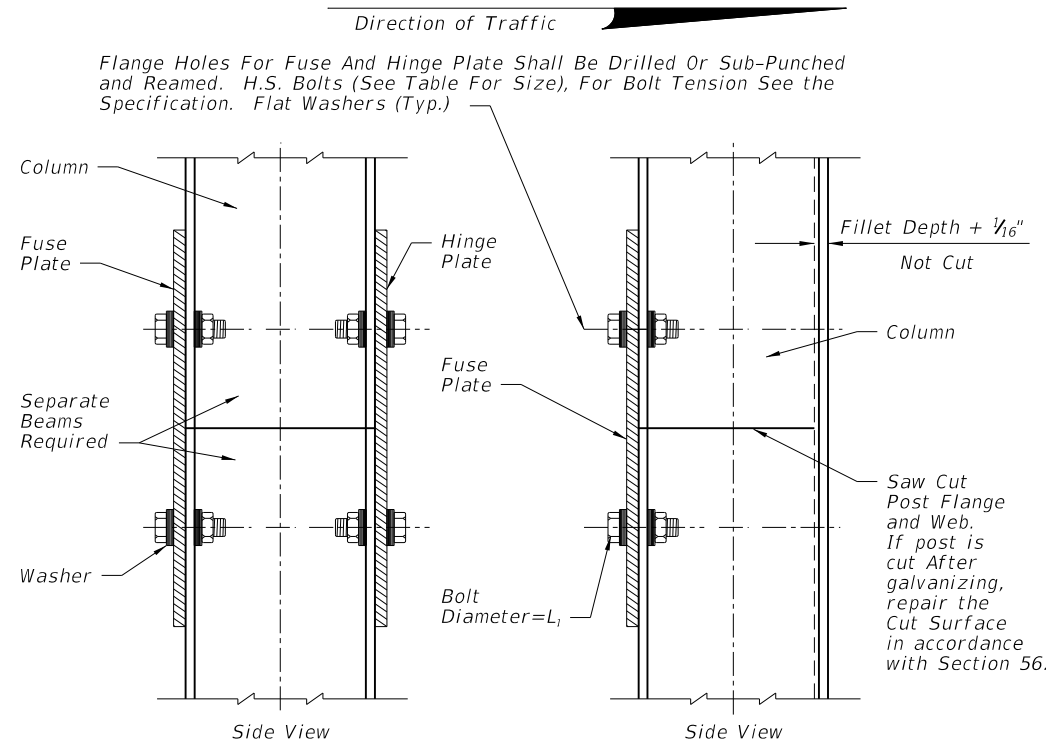

OPTIONAL HINGE **TYPICAL HINGE**

DETAIL B
 (See Fabricator Note on Sheet 1)

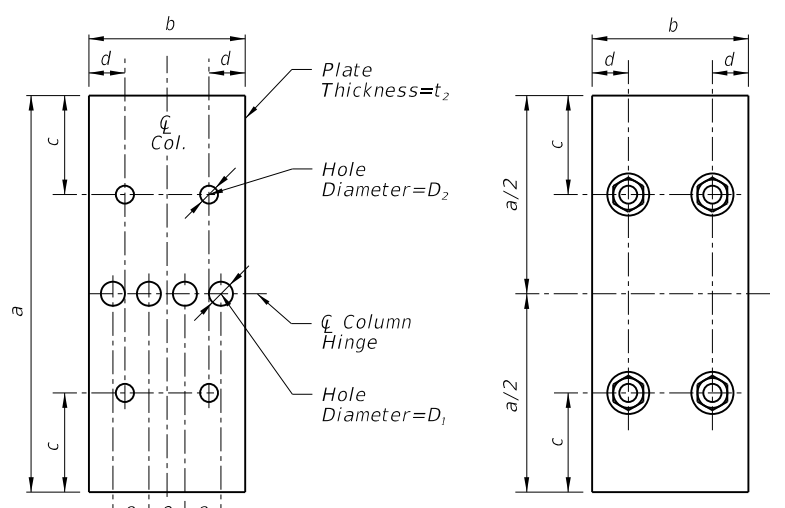

FUSE PLATE **HINGE PLATE**

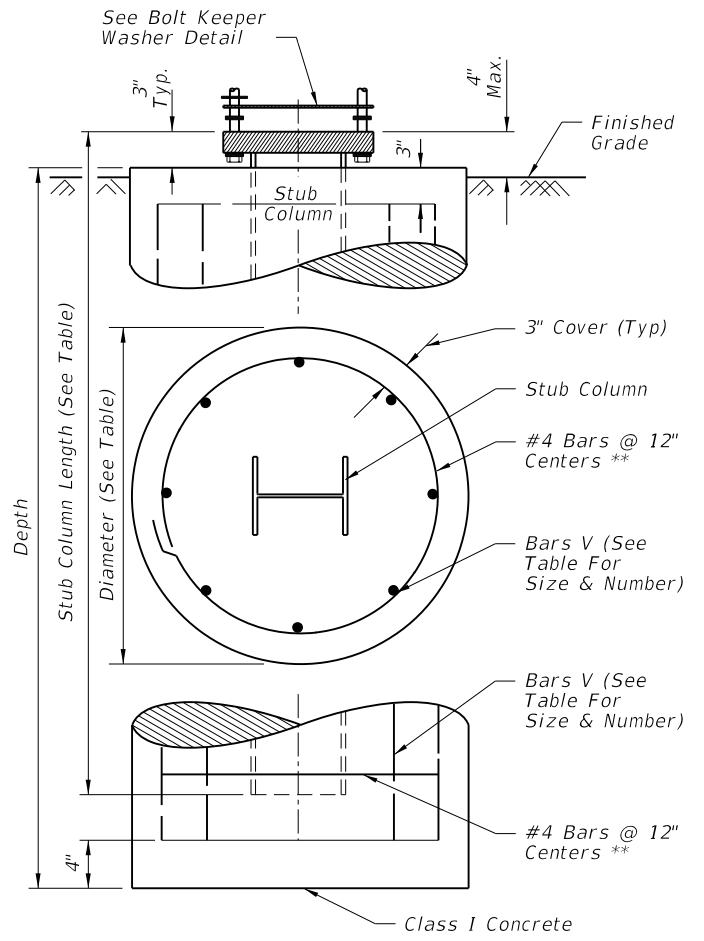

FOUNDATION ELEVATION

NOTE: All Reinforcing To Be Grade 60.

** At the Option of the Contractor, D10 Spiral Wire @ 6\"/>

Shop-weld assemblies of foundation stirrup reinforcing bars are permitted in reinforced concrete foundation provided that:

1. The reinforcing bars conform to ASTM Specification A706/706M.
2. The holding wires conform to ASTM Specification A1064.
3. The Shop welding is performed by machines under a continuous, controlled process, approved by the Engineer.
4. Quality control test are performed on shop welded specimens and the test results are available, upon request, to the Engineer.

PROCEDURE FOR ASSEMBLY OF BASE CONNECTION

1. Assemble post to stub with bolts and flat washers as shown.
2. Shim as required to plumb post (see shim detail).
3. Tighten all L₂ bolts the maximum possible with 1'-0" to 1'-3" wrench to bed washers and shims and to clean bolt threads.
4. Burr threads at junction with nut using a center punch to prevent nut loosening.

Section*	BASE CONNECTION DATA										FUSE (HINGE) PLATE DATA							SHIM		FOUNDATION DATA				
	A	B	C	D	R	t ₁	L ₂	w	Torque (lb ^f *in)	a	b	c	d	e	t ₂	D ₁	D ₂	L ₁	L	M	Dia.	Depth	Stub Length	Reinf. Bars V
S 3x5.7	4"	7"	3/4"	2"	5/16"	1"	1/2"	1/4"	90 ± 20	7-1/4"	2-3/8"	1-1/4"	1/2"	9/16"	3/8"	7/16"	9/16"	1/2"	1-1/4"	9/16"	2'-0"	4'-0"	3'-0"	10-#6
W 6x12	4"	10"	3/4"	2"	3/8"	1-5/8"	5/8"	1/4"	270 ± 45	7-1/4"	4"	1-1/4"	7/8"	15/16"	3/8"	13/16"	11/16"	5/8"	1-3/8"	11/16"	2'-0"	6'-0"	3'-0"	10-#6
W 8x18	5-1/4"	12-1/2"	7/8"	2-3/4"	7/16"	1-3/4"	3/4"	3/8"	445 ± 75	8-1/4"	5-1/4"	1-3/8"	1-1/8"	1-1/4"	3/8"	1"	13/16"	3/4"	1-3/4"	13/16"	2'-4"	7'-6"	4'-0"	8-#8
W 8x24	6-1/2"	12-1/2"	7/8"	3-1/4"	7/16"	1-3/4"	3/4"	3/8"	445 ± 75	8-1/4"	6-1/2"	1-3/8"	1-1/2"	1/2"	1"	13/16"	3/4"	2-1/8"	13/16"	2'-4"	8'-6"	4'-0"	8-#8	
W 10x33	8"	16"	1-1/4"	4-3/4"	9/16"	2"	1"	1/2"	580 ± 90	9-1/4"	8"	2"	1-3/4"	1-3/4"	5/8"	1-1/8"	1-1/16"	1"	2-3/8"	1-1/16"	2'-4"	10'-3"	4'-0"	8-#8
W 12x45	10"	18"	1-1/4"	6"	9/16"	2"	1"	1/2"	580 ± 90	11"	8"	2"	1-3/4"	1-3/4"	3/4"	1-5/16"	1-1/16"	1"	2-3/4"	1-1/16"	2'-8"	11'-3"	5'-0"	10-#8

* Designations: Normal Depth in inches and weight in pounds per linear foot.

STEEL POST, BASE, FOUNDATION & FUSE PLATE DETAILS

7/1/2014 10:30:36 AM

Direction of Traffic 

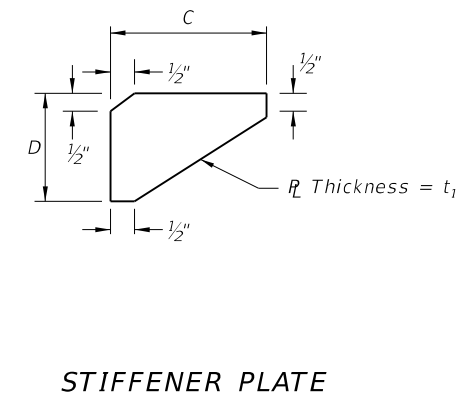
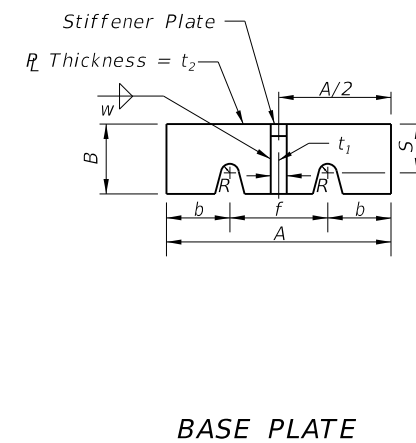
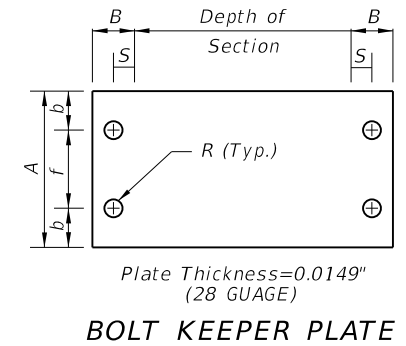
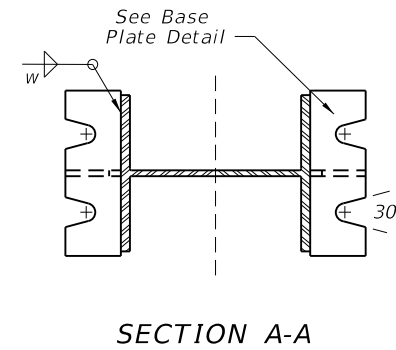
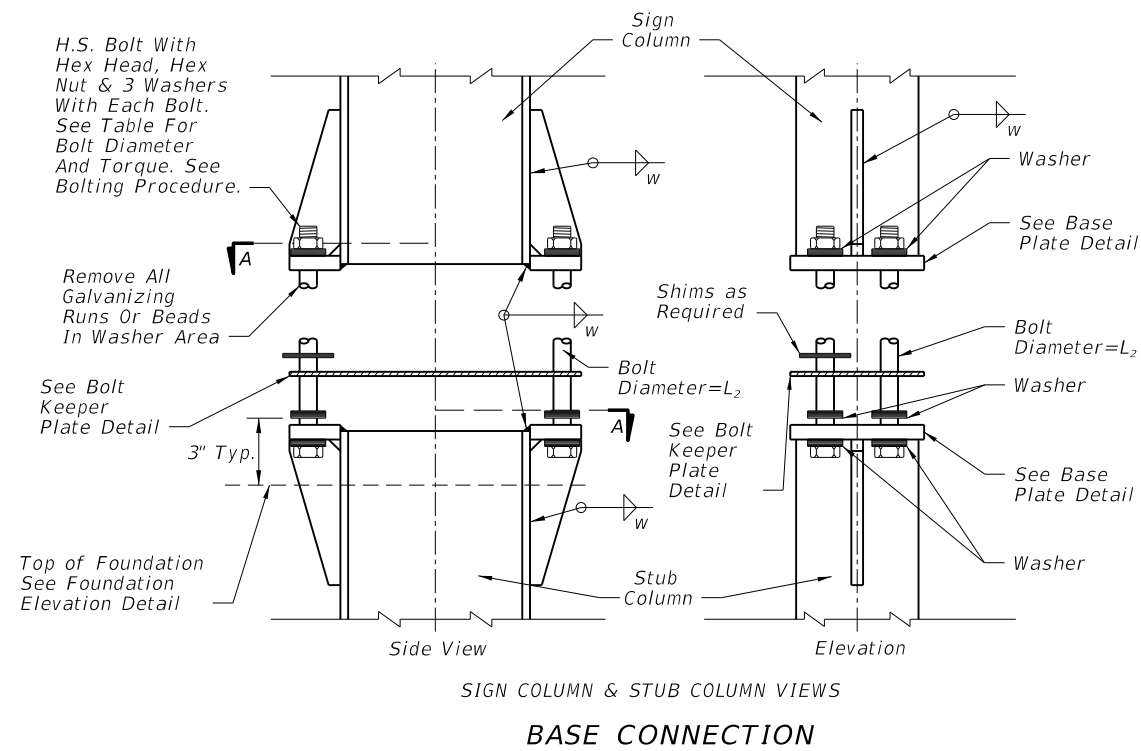

BASE CONNECTION DATA													SHIM	
Section*	A	B	C	D	L ₂	Torque (lbf-in)	R	b	f	S	t ₁	t ₂	w	L
W 6x12	4-3/4"	2"	5-1/8"	2"	5/8"	270 ± 45	3/8"	1-1/8"	2-1/2"	1-3/16"	1/2"	1/2"	1/4"	1-3/8"
W 8x18	5-3/4"	2-3/16"	6-1/4"	2-3/16"	3/4"	445 ± 75	7/16"	1-1/2"	2-3/4"	1-3/8"	1/2"	5/8"	1/4"	1-3/4"
W 8x24	7"	2-3/8"	8"	2-3/8"	3/4"	445 ± 75	7/16"	1-3/4"	3-1/2"	1-3/8"	1/2"	3/4"	5/16"	2-1/8"
W 10x33	8"	2-3/4"	8"	2-3/4"	1"	580 ± 90	9/16"	2"	4"	1-9/16"	1/2"	3/4"	5/16"	2-3/8"
W 12x45	8"	3"	8"	3"	1"	580 ± 90	9/16"	2"	4"	1-9/16"	1/2"	3/4"	5/16"	2-3/4"

* Designations: Normal Depth in inches and weight in pounds per linear foot.

STEEL POST & ALTERNATIVE BASE DETAILS

LAST REVISION 07/01/13

DESCRIPTION:



MULTI-COLUMN GROUND SIGN

INDEX NO. 11200

SHEET NO. 3 of 3

7/1/2014 10:30:39 AM