

**GENERAL NOTES**

- C-I-P Gravity Walls (Option 1) constructed as extensions of reinforced concrete retaining walls, except walls of proprietary designs, shall have the same face texture and finish as the reinforced concrete retaining wall.
- Concrete for Gravity Wall shall be Class NS per Section 347. Concrete for Scheme 3 Junction Slab and Traffic Railing shall be Class II per Section 346, unless otherwise specified in the plans.
- Reinforcing steel shall meet the requirements of Specification Section 931 (Grade 40 or 60). Smooth or Deformed Welded Wire Reinforcement (WWR) may be substituted on an equal area basis. Do not increase bar/wire spacing for Grade 60 reinforcing steel or WWR.
- When required, for adjunct guiderail, see Index No. 870 or 880 as appropriate. For adjunct Type B fence see Index No. 802.
- Joint seal to be two layers of 30# smooth roofing paper or Type D-5 geotextile fabric in accordance with Specification Section 985. Mop all contact surfaces of concrete and roofing paper or geotextile fabric with cut-back asphalt. Stop roofing paper or geotextile fabric 6" below top of wall.
- Provide a continuous 1'x1' clean gravel or crushed rock drain for wall heights 3 ft. and higher. Wrap drainage layer as shown, with Type D-3 geotextile fabric in accordance with Specification Section 985. Provide 8"x8" galvanized mesh with 1/4" openings, at the inside end of the PVC Drain Pipe. Provide 2" Ø PVC Drain Pipe (Sch. 40) at 10 ft. max. spacing (when Drainage Layer is required). Locate outermost edge of Drain Pipe a minimum of 2'-0" from wall joints.
- Cost of reinforcing steel, face texture, finish, joint seal, drain pipes, drainage layer, galvanized mesh and geotextile fabric to be included in the Contract Unit Price for Concrete Class NS, Gravity Wall. Cost of concrete for Junction Slab in Scheme 3, to be included in Contract Unit Price for Concrete Traffic Railing Barrier With Junction Slab. Adjunct railings or fences to be paid for separately.

**ESTIMATED QUANTITIES FOR C-I-P WALL**

HEIGHT (FT.)	PER LINEAR FOOT OF WALL			REINF. STEEL (LB.)	WEEP HOLES & DRAIN REQD.
	CLASS NS CONCRETE (CY)				
	SCHEME 1	SCHEME 2	SCHEME 3**		
1'	0.08	0.11 (0.20*)	0.03	3 (4*)	No
2'	0.14	0.20 (0.32*)	0.09	4 (5*)	No
3'	0.22	0.32 (0.47*)	0.29	5 (6*)	Yes
4'	0.32	0.47 (0.65*)	0.43	6 (7*)	Yes
5'	0.43	0.65 (0.85*)	0.60	7 (8*)	Yes

**ESTIMATED QUANTITIES NOTES:**

For Scheme 3 Junction Slab and Traffic Railing see the referenced Design Standards for estimated quantities.

- \* Quantity for 2'-0" Toe Depth in Scheme 2.
- \*\* Quantity for Scheme 3 assumes 1'-3" thick coping above Gravity Wall.

**CROSS REFERENCE:**  
See Sheet 2 for Segmental Block Wall (SBW) details.

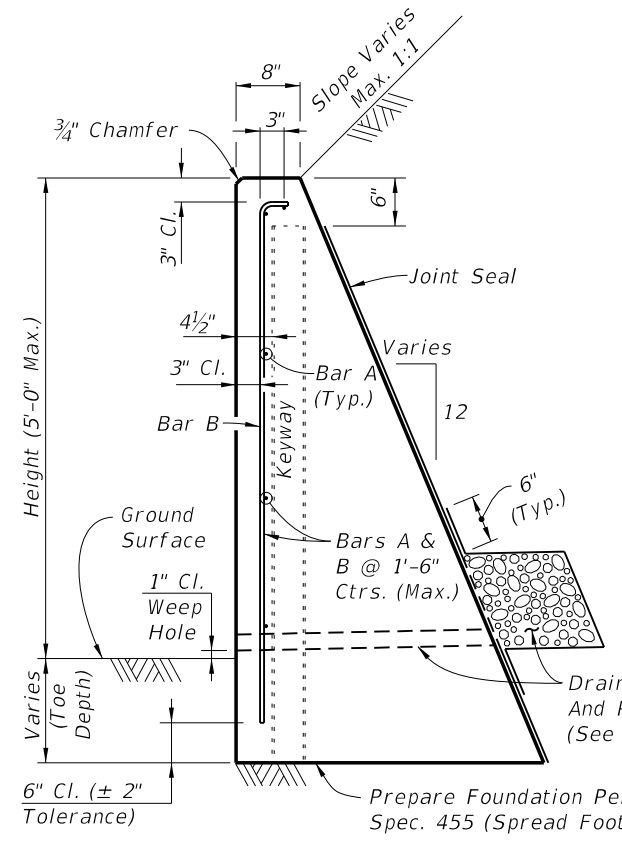
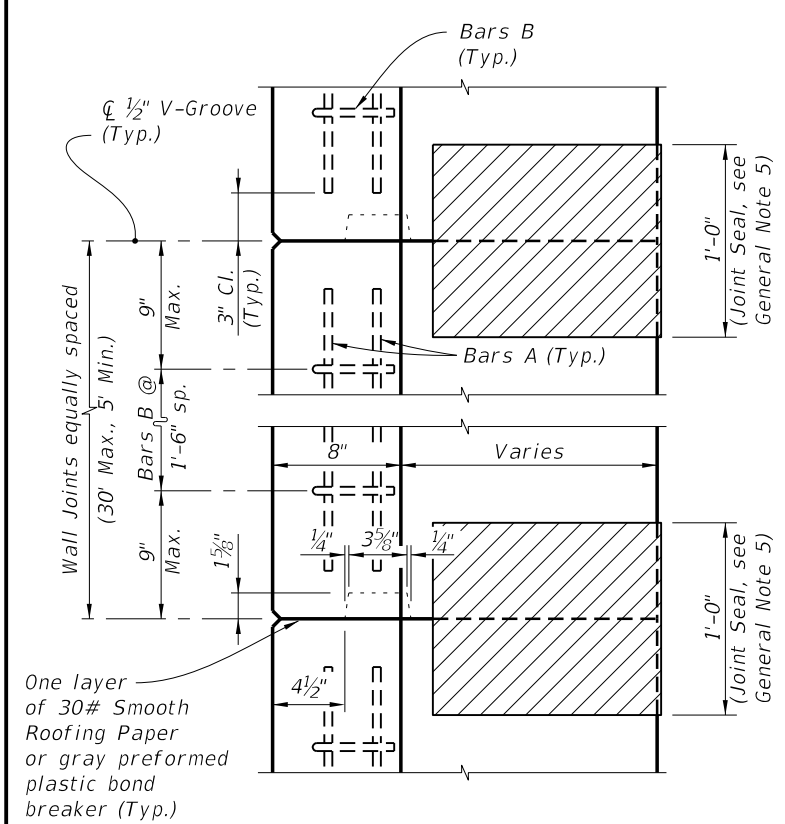

**TYPICAL SECTION C-I-P CONCRETE GRAVITY WALL (OPTION 1)**

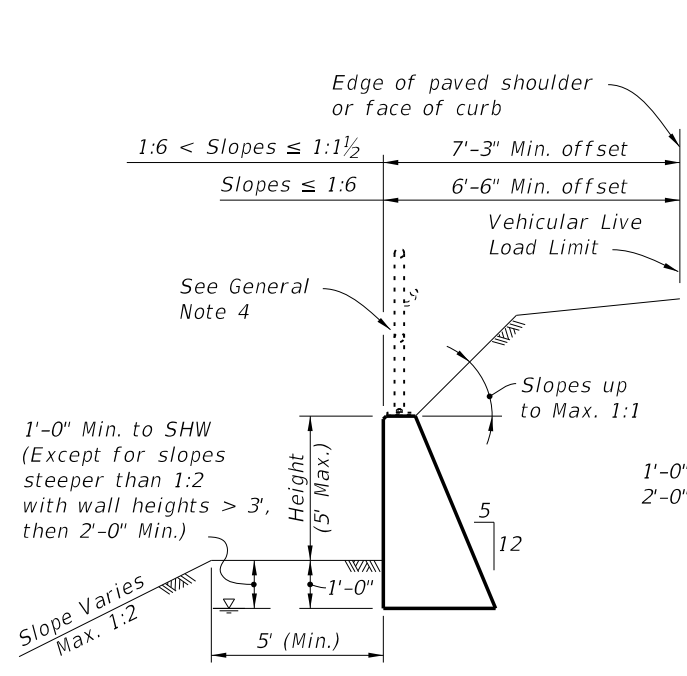

**SCHEME 1 (No Traffic Loading Effects)**

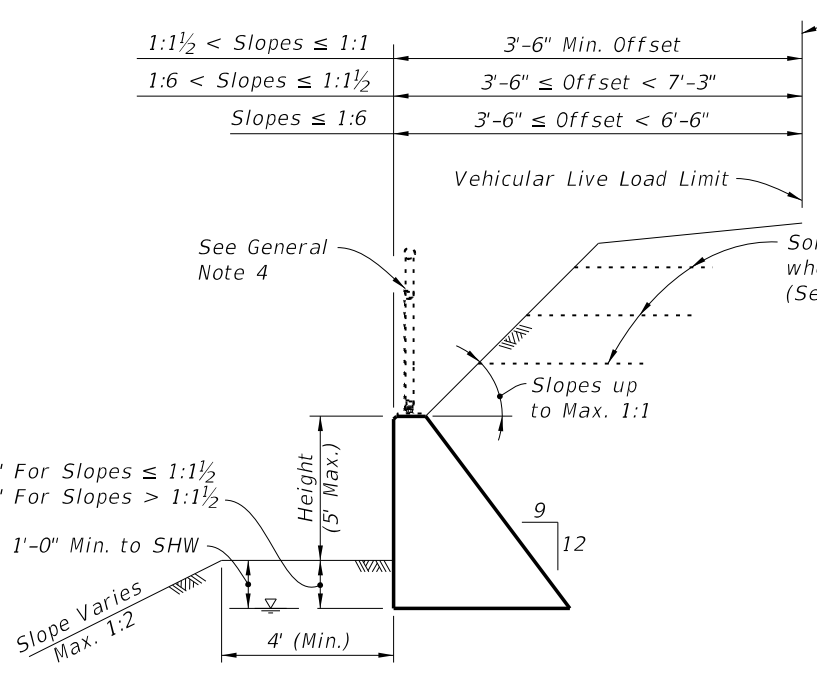

**SCHEME 2 (With Traffic Loading or Slopes > 1:1 1/2)**

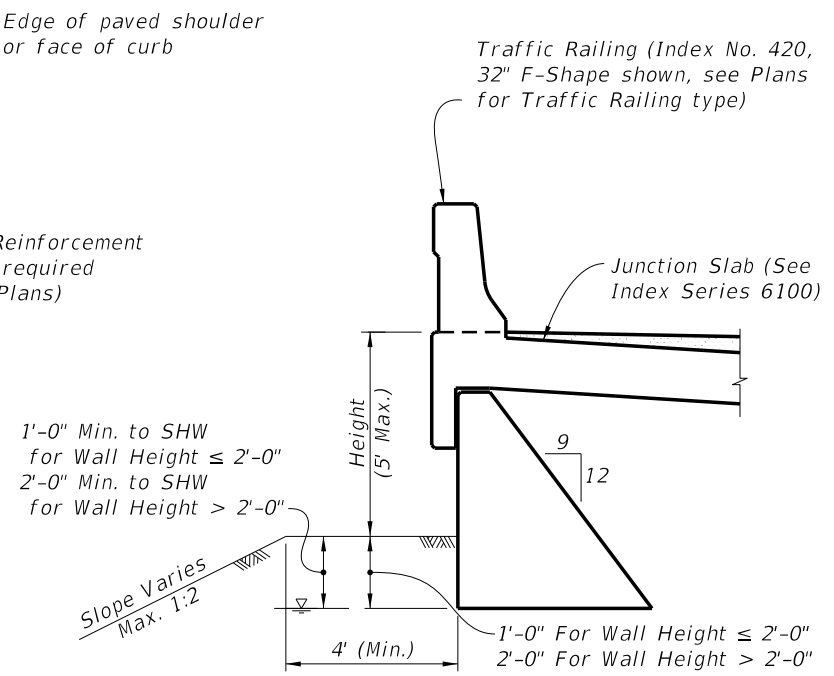

**SCHEME 3 (With Traffic Railing)**

BILL OF REINFORCING STEEL		
MARK	SIZE	LENGTH
A	4	As Reqd.
B	4	As Reqd.

BAR BENDING DIAGRAM	
<p>BAR A</p>	<p>BAR B</p>

**NOTES:**

- All bar dimensions are out to out.
- Lap splices for Bars A must be a minimum of 1'-6".

6/27/2014 1:30:42 PM