

NOTES

PIPE RAILING & POSTS:

Pipe Rails and Posts shall be in accordance with ASTM A53 Grade B for standard weight pipe and ASTM A500 Grade B, C or D or ASTM A501 for structural tube. Bars for handrail supports shall be ASTM A36. Posts and End Rails shall be fabricated and installed plumb, ± 1" tolerance when measured at 3'-6" above the foundation. Corners and changes in tangential longitudinal alignment, may be made continuous with a 9" bend radius or terminated at adjoining sections with a standard end hoop when handrails are not required. For changes in tangential longitudinal alignment greater than 45°, posts shall be positioned at a maximum distance of 2'-0" each side of the corner and shall not be located at the corner apex. For curved longitudinal alignments the top and bottom rails and handrails shall be shop bent to match the alignment radius.

RAILING MEMBER DIMENSIONS TABLE			
MEMBER	DESIGNATION	OUTSIDE DIMENSION	WALL THICKNESS
Posts	2" NPS (Sch. 40)	2.375"	0.154"
Rails	2" NPS (Sch. 40)	2.375"	0.154"
Rail Joint/Splice Sleeves	1½" NPS (Sch. 40)	1.900"	0.145"
Handrails Joint/Splice Sleeves	1" NPS (Sch. 40)	1.315"	0.133"
Handrails	1½" NPS (Sch. 40)	1.900"	0.145"
Handrail Support Bar	1" Ø Round Bar	1.000"	N/A

BASE PLATES:

Base Plates shall be in accordance with ASTM A36 or ASTM A709 Grade 36.

SHIM PLATES:

Shim Plates shall be aluminum in accordance with ASTM B209, Alloy 6061 or 6063. Shim plates shall be used for foundation height adjustments greater than ¼" and localized irregularities greater than ⅛". Field trim shim plates when necessary to match the contours of the foundation (See Sheet 5 for additional details). Beveled shim plates may be used in lieu of trimmed flat shim plates shown. Stacked shim plates must be bonded together with adhesive bonding material and limited to a maximum total thickness of b", unless longer anchor bolts are provided for the exposed thread length.

COATINGS:

The railing shall be hot-dip galvanized after fabrication in accordance with Section 962 of the Specifications. All nuts, bolts and washers shall be hot-dip galvanized in accordance with Section 962 of the Specifications.

ANCHOR BOLTS:

Anchor bolts shall be in accordance with ASTM F1554 Grade 36. Headless anchor bolts for Adhesive Anchors shall be threaded full length. Cutting of reinforcing steel is permitted for drilled hole installation. All anchor bolts shall have single self-locking hex nuts. Tack welding of the nut to the anchor bolt may be used in lieu of self-locking nuts. All nuts shall be in accordance with ASTM A563 or ASTM A194. Flat Washers shall be in accordance with ASTM F436 and Plate Washers (for long slotted holes only), shall be in accordance with ASTM A36 or ASTM A709 Grade 36. After the nuts have been snug tightened, distort the anchor bolt threads or disfigure the top of stud to prevent removal of the nuts. Distorted threads and tack welds shall be coated with a galvanizing compound in accordance with the Specifications.

RESILIENT AND NEOPRENE PADS:

Resilient and Neoprene pads shall be in accordance with Specification Section 932, except that testing of the finished pads shall not be required. Neoprene pads shall be durometer hardness 60 or 70.

JOINTS:

All fixed joints are to be welded all around and plug welds ground smooth. Remove burs and weld splatter, additionally remove any sharp edges on rails to prevent injury. Expansion Joints shall be spaced at a maximum of 30'-0". Field splices similar to the expansion joint detail may be approved by the Engineer to facilitate shipping and handling, but rails must be continuous across a minimum of two posts. Only use the Continuity Field Splice (Detail "E") to make the railing continuous for unforeseen field adjustments.

WELDING:

All welding shall be in accordance with the American Welding Society Structural Welding Code (Steel) ANSI/AWS D1.1 (current edition). Weld metal shall be E60XX or E70XX. Nondestructive testing of welds is not required.

SHOP DRAWINGS:

Details addressing project specific geometry (line & grade) showing post and expansion joint locations must be submitted by the Contractor for the Engineer's approval prior to fabrication of the railing. Shop drawings shall be in accordance with the Specifications.

PAYMENT:

Guiderail shall be paid for under the contract unit price for Pipe Guiderail (Steel), LF (Item No. 515-1-1). Payment for the Guiderail will be plan quantity measured as the length along the center line of the top rail, and includes rails, posts, rail splice assembly, base plates, anchor bolts, nuts, washers, resilient or neoprene pads and all incidental materials and labor required to complete installation of the Guiderail.

6/24/2014 11:10:31 AM

LAST REVISION 07/01/14	REVISION	DESCRIPTION:	 2015 DESIGN STANDARDS	STEEL PIPE GUIDERAIL	INDEX NO. 880	SHEET NO. 1 of 5
---------------------------	----------	--------------	--	-----------------------------	-------------------------	----------------------------

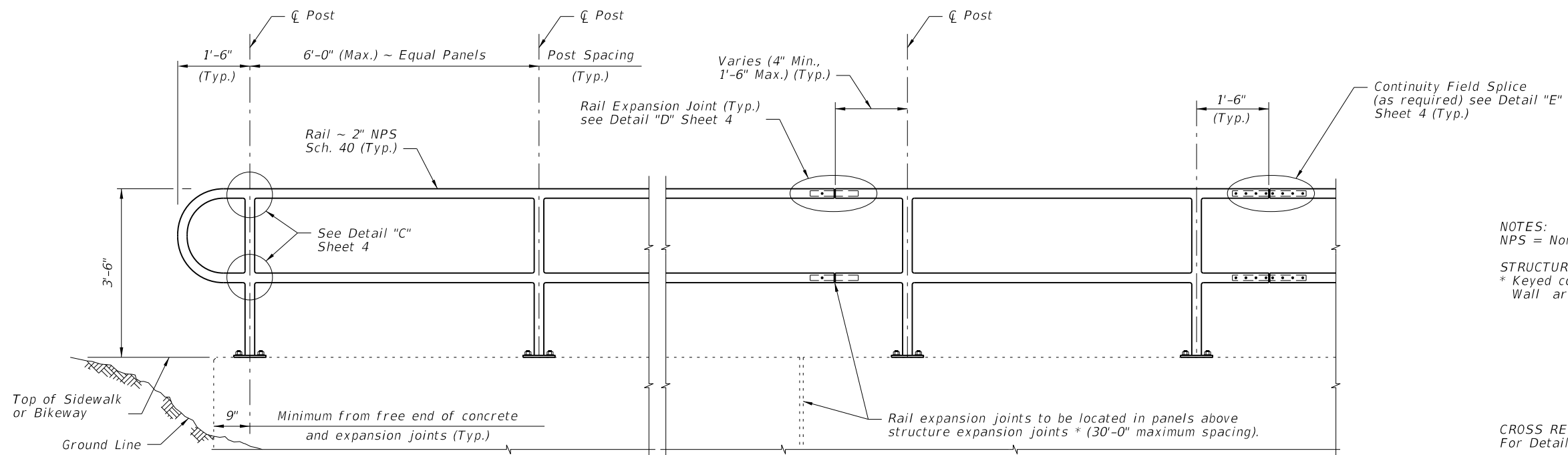

NOTES:
 NPS = Nominal Pipe Size
 STRUCTURES EXPANSION JOINTS NOTE:
 * Keyed construction joints in Index No. 6011 Gravity Wall are not considered to be expansion joints.

CROSS REFERENCE:
 For Details "C", "D" and "E", see Sheet 4.

ELEVATION

TYPICAL RAILING DETAILS & RAILINGS ON GRADES 0% TO 5%

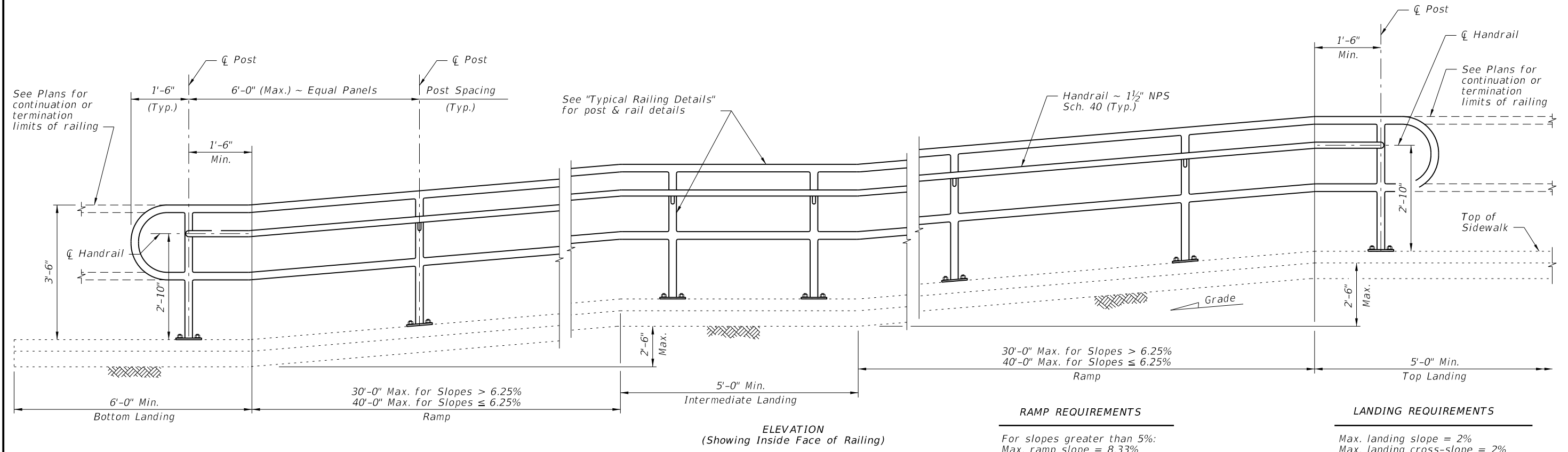

ELEVATION
 (Showing Inside Face of Railing)

RAMP REQUIREMENTS

For slopes greater than 5%:
 Max. ramp slope = 8.33%
 Max. ramp cross-slope = 2.0%

LANDING REQUIREMENTS

Max. landing slope = 2%
 Max. landing cross-slope = 2%

RAILINGS ON GRADES STEEPER THAN 5% TO 8.33%

6/24/2014 11:10:37 AM

LAST REVISION 07/01/14	REVISION	DESCRIPTION:	 2015 DESIGN STANDARDS	STEEL PIPE GUIDERAIL	INDEX NO. 880	SHEET NO. 2 of 5
---------------------------	----------	--------------	------------------------------	----------------------	-------------------------	----------------------------

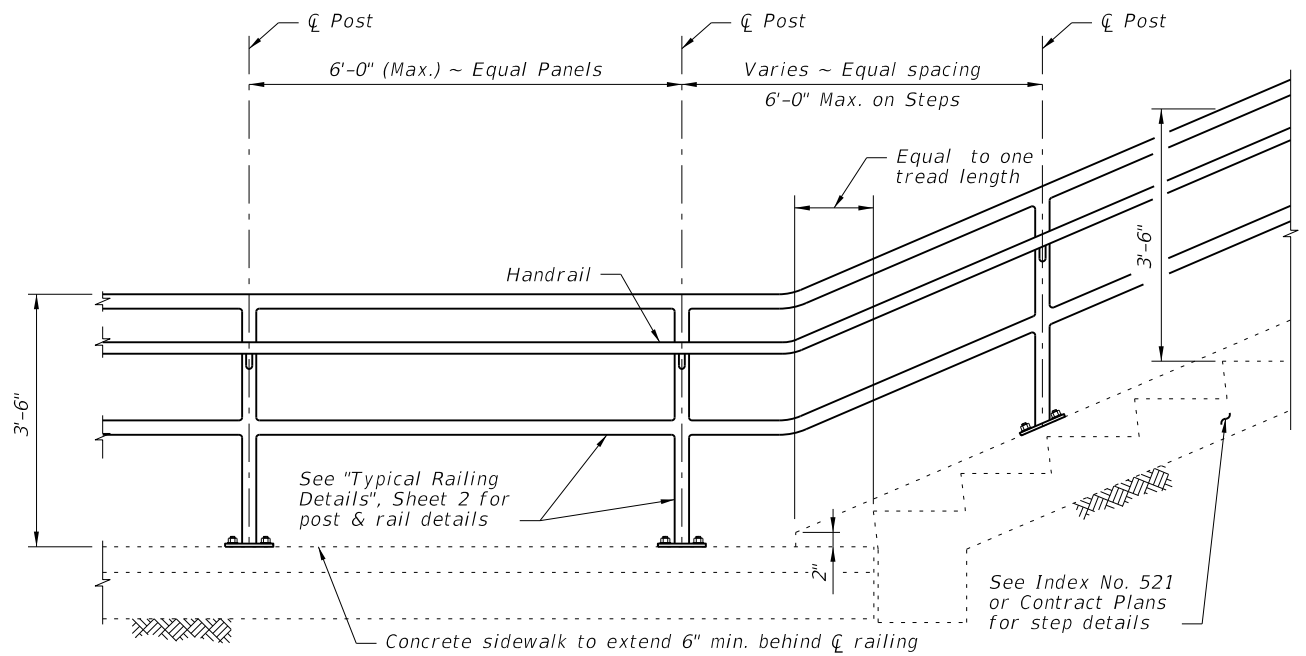

RAILING CONTINUATION BEYOND STEPS
(Bottom shown, Top similar)

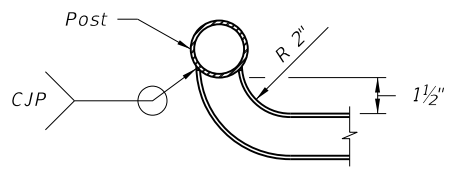

DETAIL "A" - PLAN VIEW
HANDRAIL TERMINATION

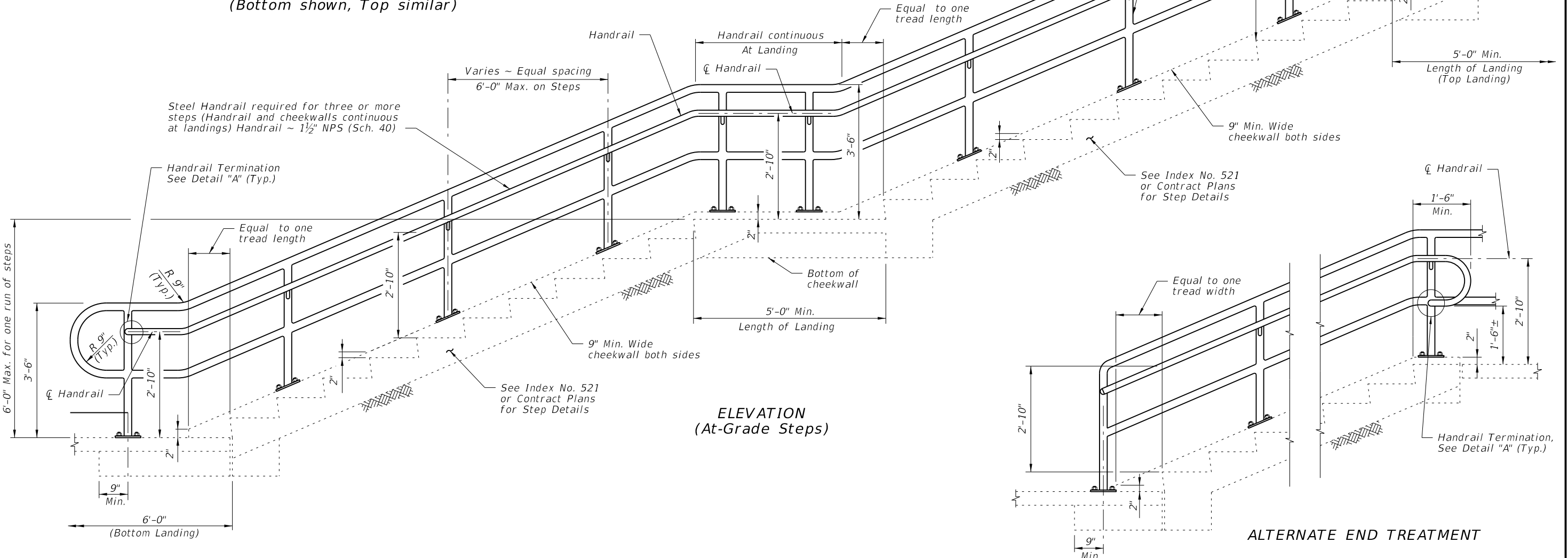

ELEVATION
(At-Grade Steps)

ALTERNATE END TREATMENT

GUIDERAIL ON STEPS & STAIRS

6/24/2014 11:10:38 AM

LAST REVISION 01/01/12	REVISION	DESCRIPTION:	2015 DESIGN STANDARDS	STEEL PIPE GUIDERAIL	INDEX NO. 880	SHEET NO. 3 of 5
---------------------------	----------	--------------	------------------------------	-----------------------------	-------------------------	----------------------------

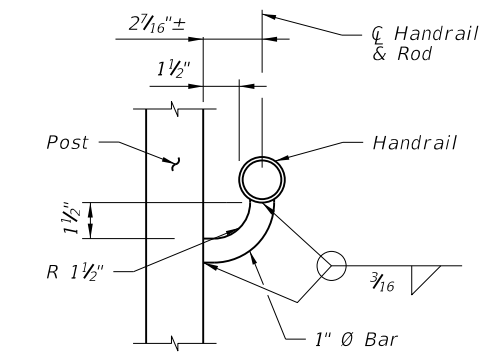

**SECTION B-B
(Handrail Connection)**

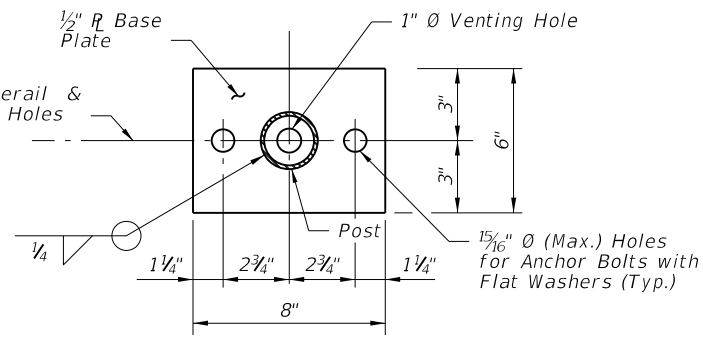

**SECTION C-C
BASE PLATE DETAIL**

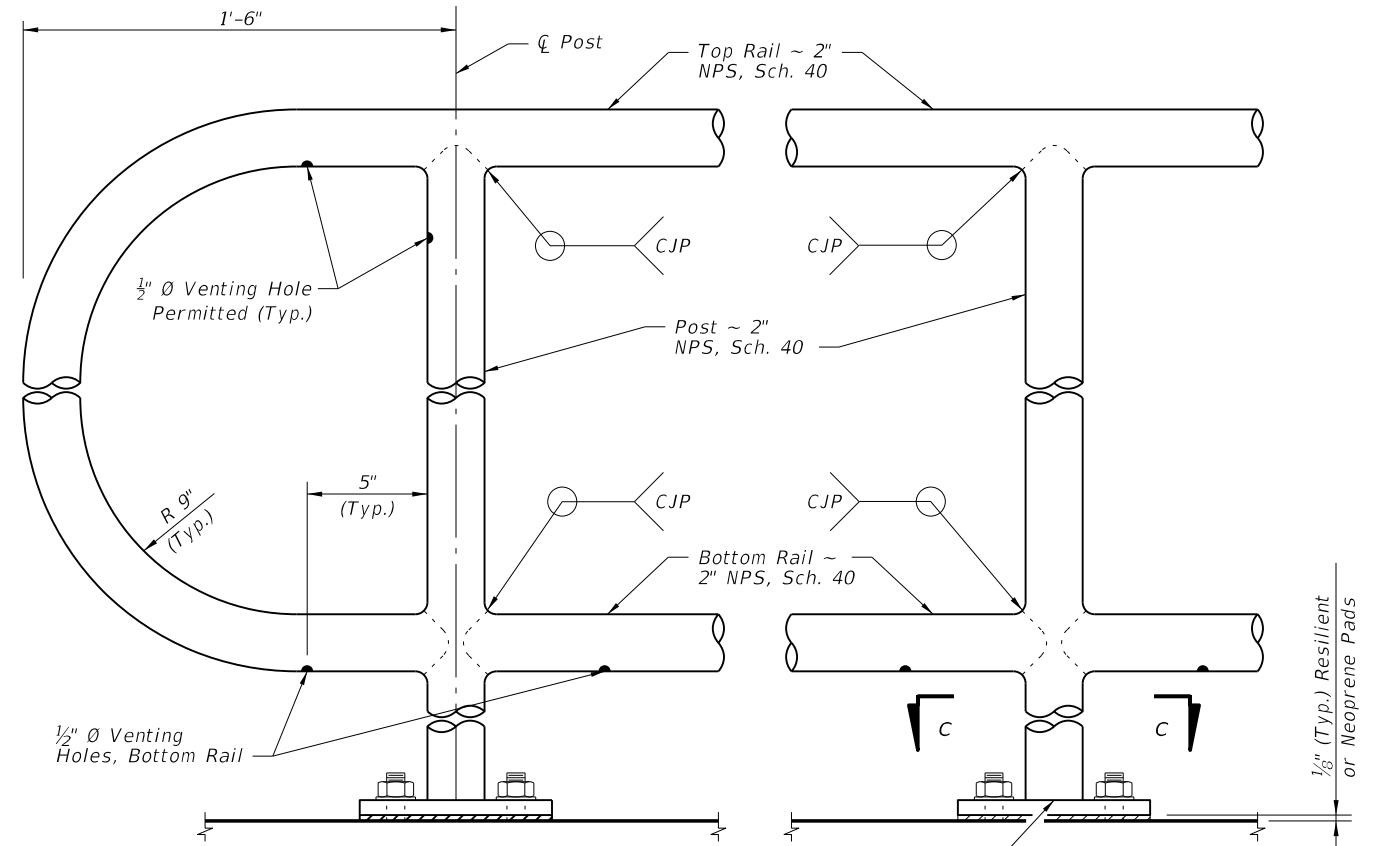

**DETAIL "C" - RAIL CONNECTIONS
(Handrail Not Shown)**

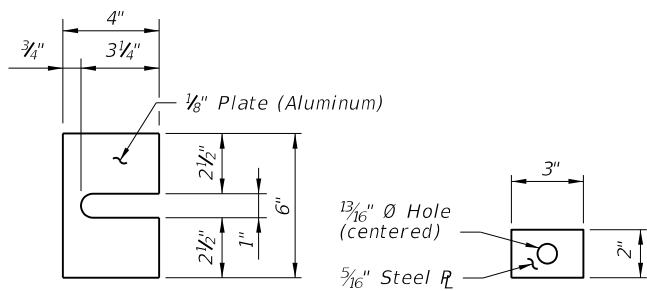

**SHIM PLATE
DETAIL**

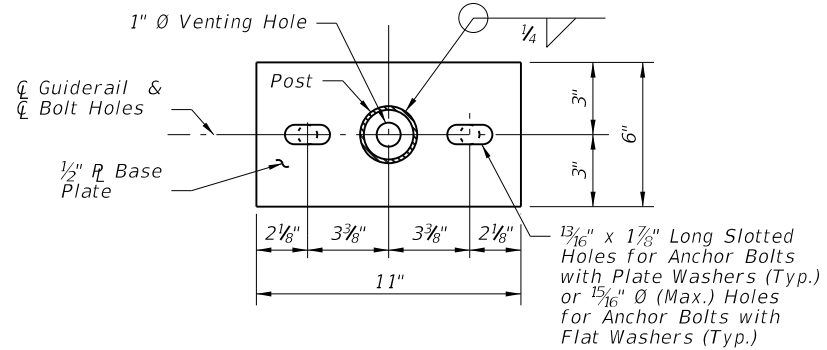

**ALTERNATE BASE
PLATE DETAIL
(Recommended for Top of Step Cheekwalls)**

**PLATE WASHER
DETAIL**

1/4" Ø x 3/4" Pan Head
Stainless Steel (Type 316
or 18-8 Alloy) Set Screw.
Set Screw must be set
flush against outside face
of rail (Typ.)

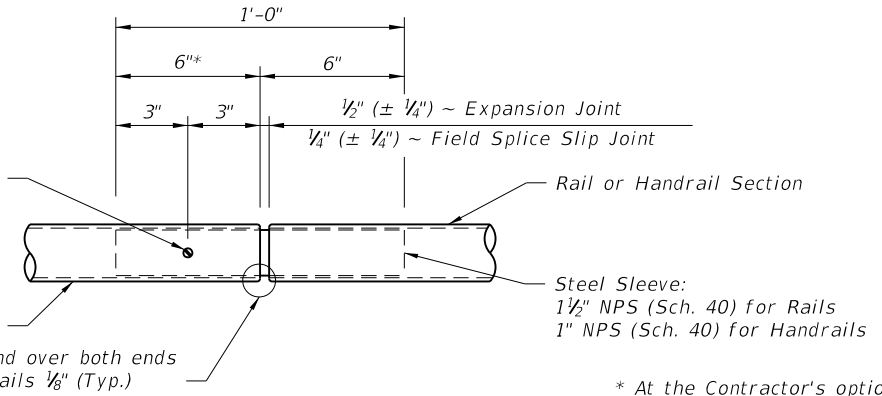

**DETAIL "D" - EXPANSION JOINT
(FIELD SPLICE SLIP JOINT SIMILAR)**

* At the Contractor's option, embedded length may be 4" when a 3/4" Ø plug weld is substituted for the 1/4" Ø set screw.

1/4" Ø x 3/4" Pan Head
Stainless Steel (Type 316
or 18-8 Alloy) Set Screws.
Set Screws must penetrate
the full wall thickness of the
inner sleeve and set flush
against outside face of rail
(Typ.)

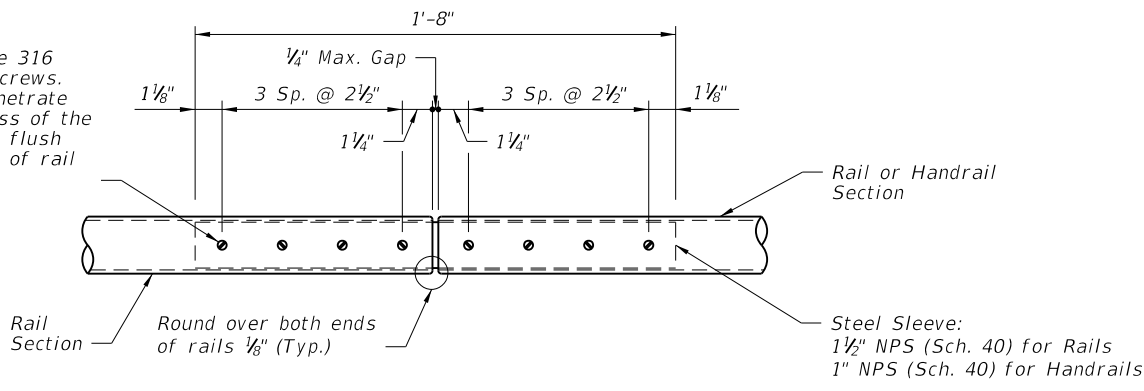

**DETAIL "E" - CONTINUITY
FIELD SPLICE**

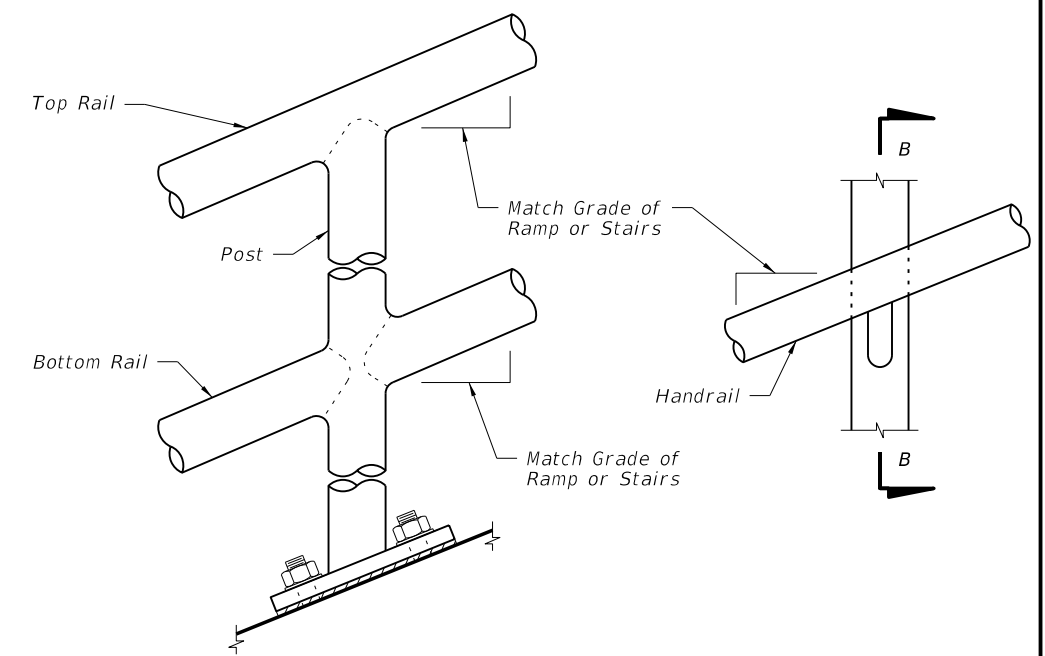

**DETAIL "B" - RAIL AND HANDRAIL
(Showing Sloped Condition for Stairs or Ramp)**

CROSS REFERENCE:
For locations of Details "C", "D" and "E", see Sheet 2.

6/24/2014 11:10:39 AM

LAST REVISION 07/01/14	REVISION	DESCRIPTION:	 2015 DESIGN STANDARDS	STEEL PIPE GUIDERAIL	INDEX NO. 880	SHEET NO. 4 of 5
---------------------------	----------	--------------	------------------------------	-----------------------------	------------------	---------------------

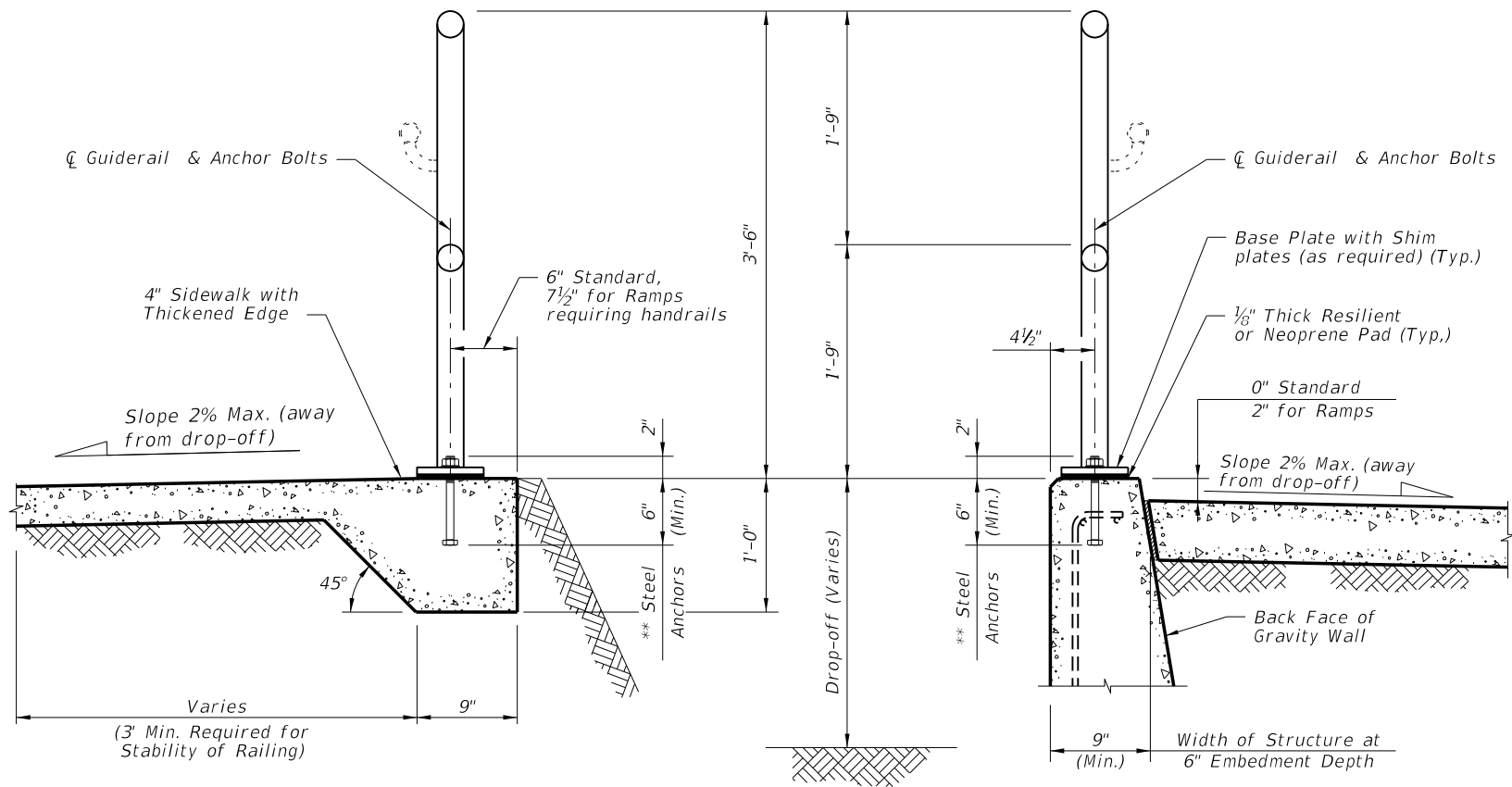

TYPICAL SECTION ON CONCRETE SIDEWALK

TYPICAL SECTION ON GRAVITY WALL
(Other Retaining Walls Similar)

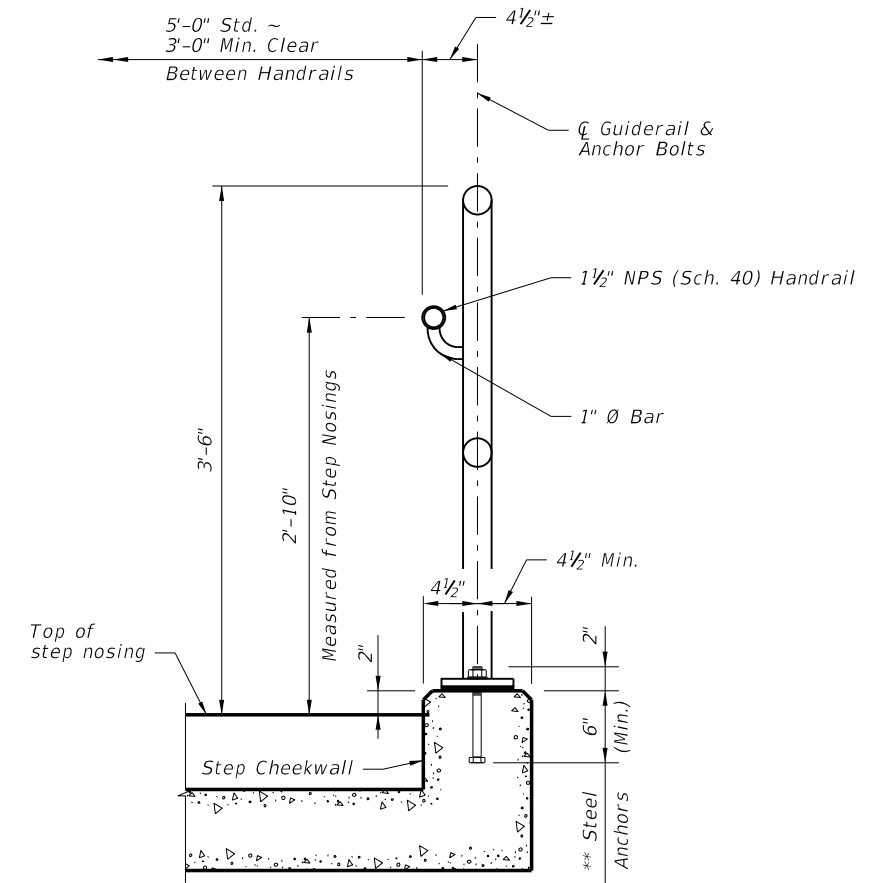

TYPICAL SECTION ON STEPS & STAIRS

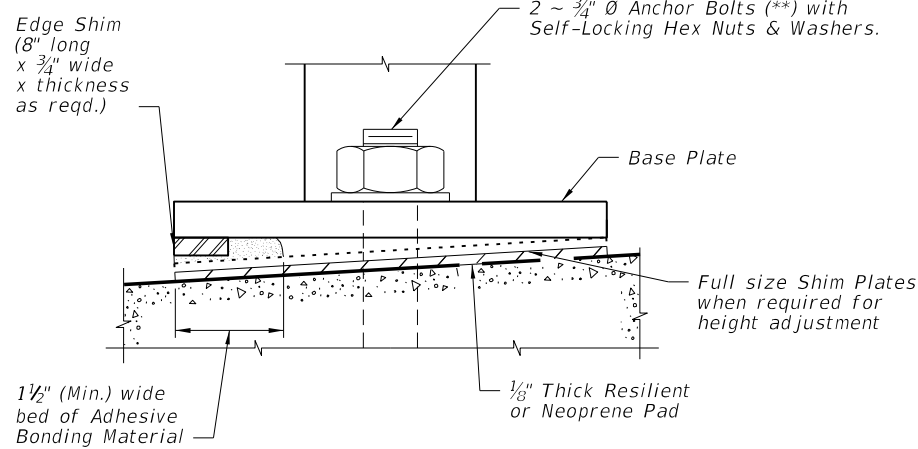

DETAIL "F" (OPTIONAL SHIMMING DETAIL FOR CROSS SLOPE CORRECTION)
(Used in lieu of Beveled Shim Plates)

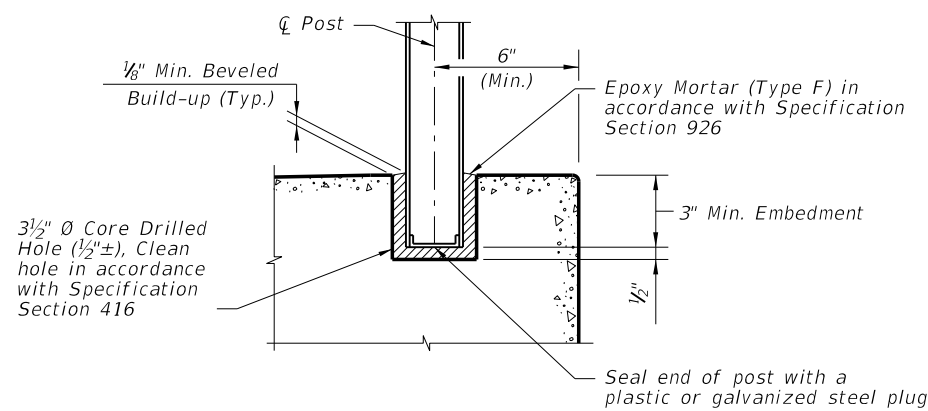

OPTIONAL SIDEWALK ANCHORAGE DETAIL

NOTES:
 ** 2 ~ 3/4" Ø x 8" Steel Anchors: Galvanized Steel Bolts (As Shown) (C-I-P); Galvanized U-Bolts Permitted (C-I-P); Galvanized Adhesive Anchors Permitted (***) ; Expansion Anchors Not Permitted.
 *** Adhesive anchors shall be fully threaded headless anchor bolts set in drilled holes (manufacturer recommended diameter) with an Adhesive Bonding Material System in accordance with Specification Section 937 and installed in accordance with Specification Section 416. The minimum embedment is 6".

6/24/2014 11:10:39 AM

LAST REVISION 01/01/11	REVISION	DESCRIPTION:	 2015 DESIGN STANDARDS	STEEL PIPE GUIDERAIL	INDEX NO. 880	SHEET NO. 5 of 5
---------------------------	----------	--------------	------------------------------	----------------------	------------------	---------------------