

Pedestrian Railing
(Picket Railing shown,
other railings similar)

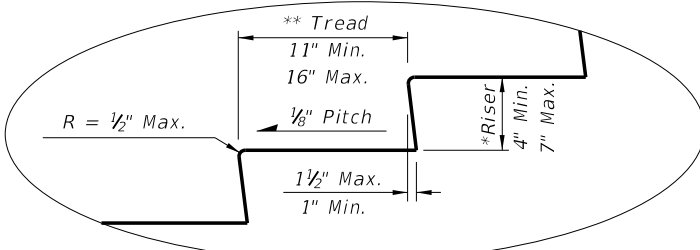

STAIR TREAD AND RISER DETAILS

* The greatest riser height within the flight of steps shall not exceed the smallest by more than 3/8".
** The greatest tread depth within the flight of steps shall not exceed the smallest by more than 3/8".

Pedestrian Railing
(Picket Railing shown,
other railings similar)

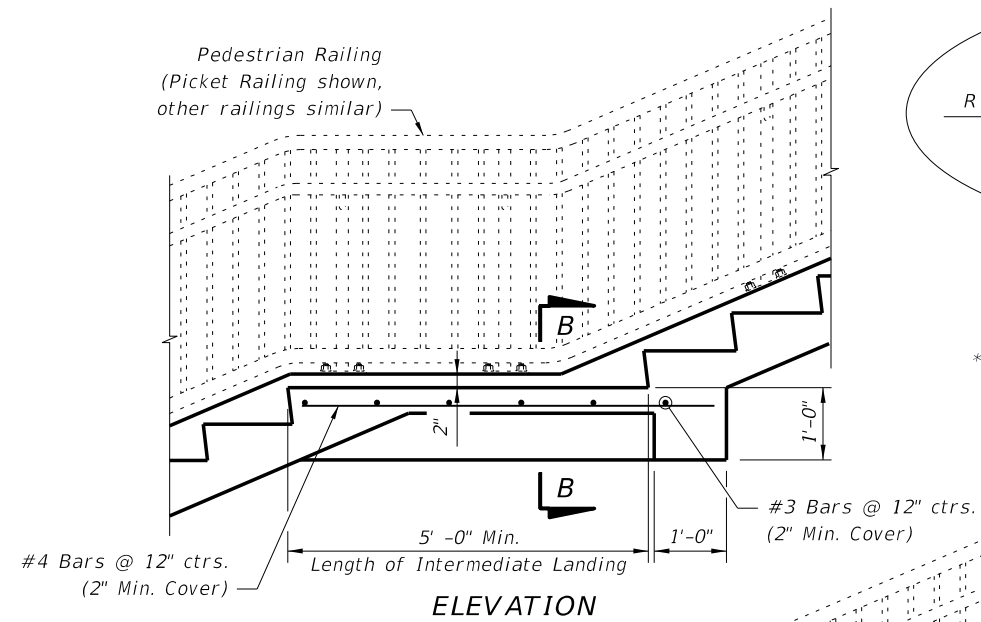

ELEVATION

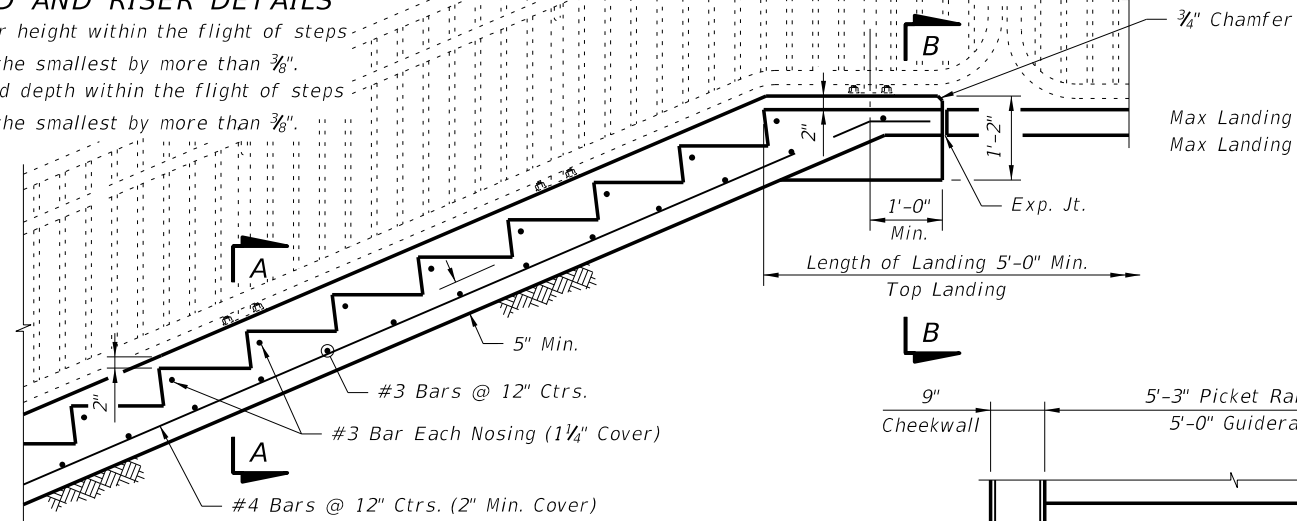

NOTE: Provide a maximum of 12 risers between landings.

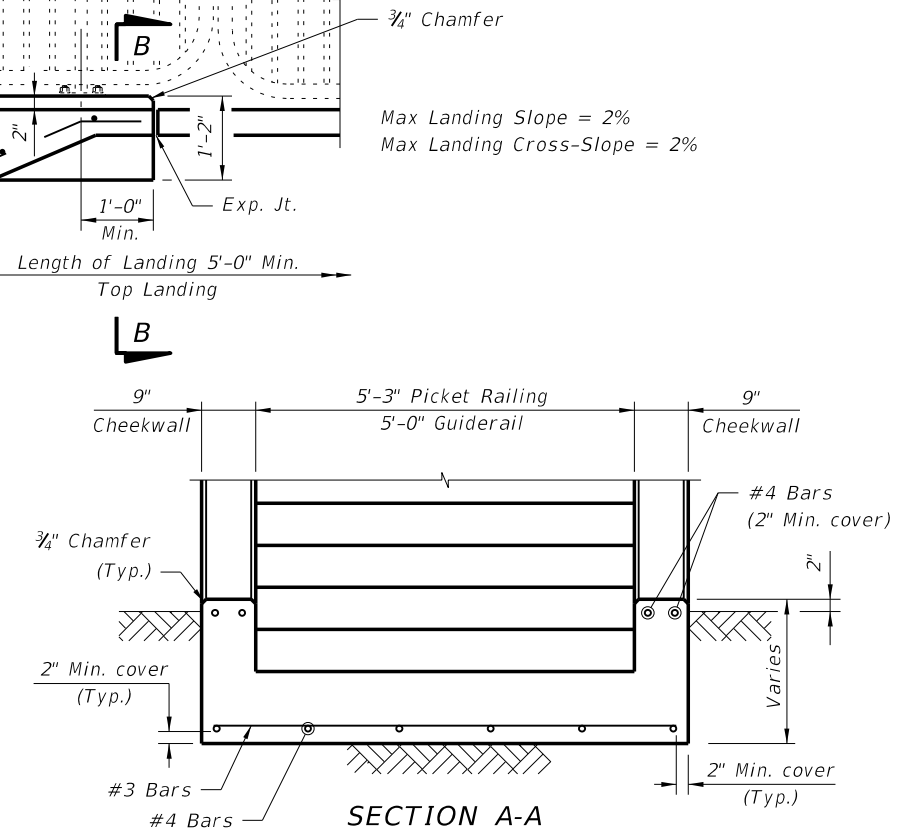

SECTION A-A

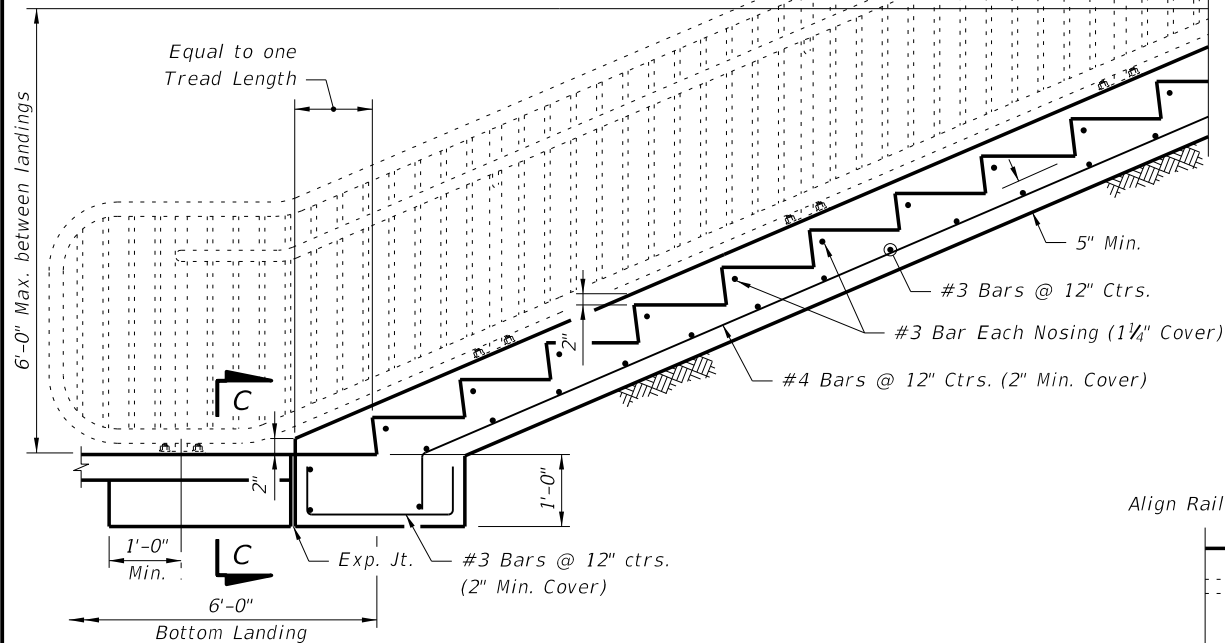

Max Landing Slope = 2%
Max Landing Cross-Slope = 2%

NOTES:

1. Do not use this Index for suspended (structural) steps or stairways.
2. Construct steps in accordance with Section 522 of the FDOT Standard Specifications.
3. Concrete: Class NS, Specification 347.
4. Tread Finish: Broom finish parallel to steps unless otherwise shown in Plans.
5. Pedestrian Railing: See Index Nos. 852, 862, 870, 880 or Project Specific Design.
6. Cost of concrete steps, landings and cheekwalls shall be paid for under the contract unit price for Class NS Concrete (Concrete Steps), CY. Cost of reinforcing steel shall be paid for under the contract unit price for Reinforcing Steel (Miscellaneous), LB.

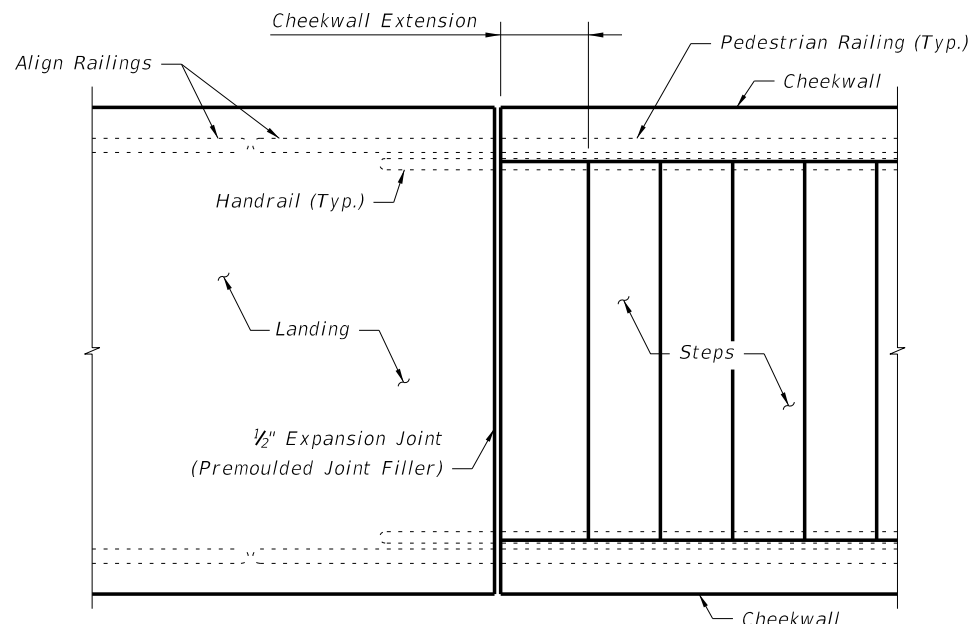

PLAN AT JUNCTION OF STEPS & LANDING
(Bottom Landing shown, Top Landing similar)

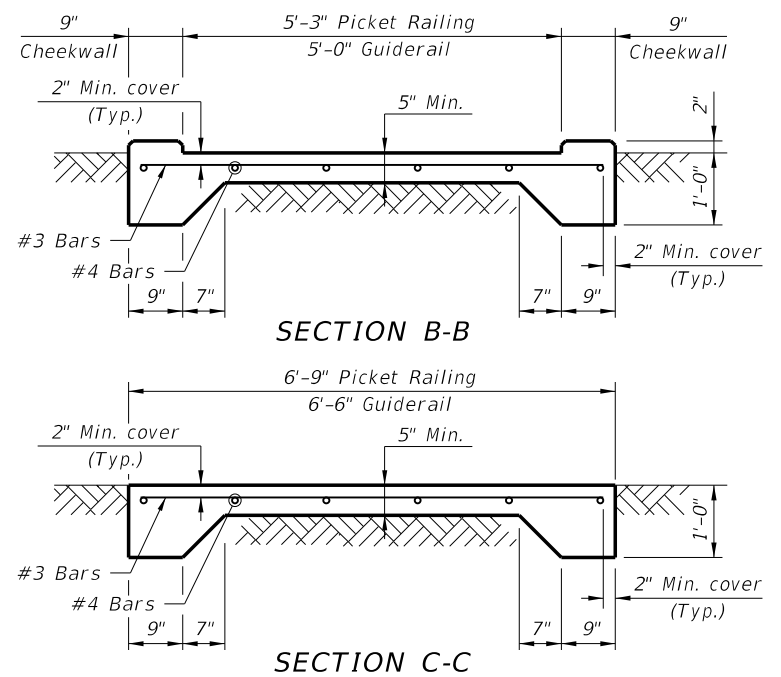

SECTION B-B

SECTION C-C

5/20/2014 3:20:39 PM

LAST REVISION 07/01/13	DESCRIPTION:	 2015 DESIGN STANDARDS	CONCRETE STEPS	INDEX NO. 521	SHEET NO. 1 of 1
---------------------------	--------------	---------------------------	-----------------------	------------------	---------------------