

GENERAL NOTES

CONCRETE: Concrete for the Traffic Railing (Vertical Face Retrofit) and replacement curb sections shall be Class IV. Concrete for Curb Transition Blocks shall be Class II (Bridge Deck).

REINFORCING STEEL: Reinforcing steel shall be ASTM A615, Grade 60, except Expansion Dowel Bar B which shall be ASTM A36 smooth round bar hot-dip galvanized in accordance with the Specifications.

EXPANSION SLEEVE ASSEMBLY: Pipe sleeve shall be ASTM D2241 PVC pipe, SDR13.5. End Cap shall be ASTM D2466 PVC socket fitting, Schedule 40. End of Sleeve assembly at railing open joint shall be sealed with silicone to prevent concrete intrusion during railing casting. A compressible expanded polystyrene plug is required in the opposite end of the assembly for correct dowel positioning during railing casting. Correct dowel positioning is required in order to provide for thermal movement of the deck.

ADHESIVE-BONDED ANCHORS AND DOWELS: Adhesive Bonding Material Systems for Anchors and Dowels shall comply with Specification Section 937 and be installed in accordance with Specification Section 416. The field testing proof loads required by Specification Section 416 shall be 23,800 lbs. for Dowel Bars 6D on the inside face (traffic side) of the railing (1'-0" embedment) and 18,500 lbs for Dowel Bars 6D along the outside face of the traffic railing (5" min. embedment).

BRIDGES ON CURVED ALIGNMENTS: The details presented in these Standards are shown for bridges on tangent alignments. Details for bridges on horizontally curved alignments are similar.

BARRIER DELINEATORS: Barrier Delineators shall meet Specification Section 993. Install barrier delineators on top of the Traffic Railing along the entire length of bridge 2" from the face on the traffic side at the spacing shown in the table below. Barrier Delineator color (white or yellow) shall match the color of the near edgeline.

PAYMENT: Concrete Traffic Railing- Bridge Retrofit- Post & Beam Railing (each) includes all materials and labor required to demolish a portion of the existing structure where required and to construct the concrete portion of the retrofit railings. Guardrail Bridge Anchorage Assembly (each) includes all barrier delineators for the entire bridge length, transition blocks, and necessary hardware to complete the Guardrail transitions shown.

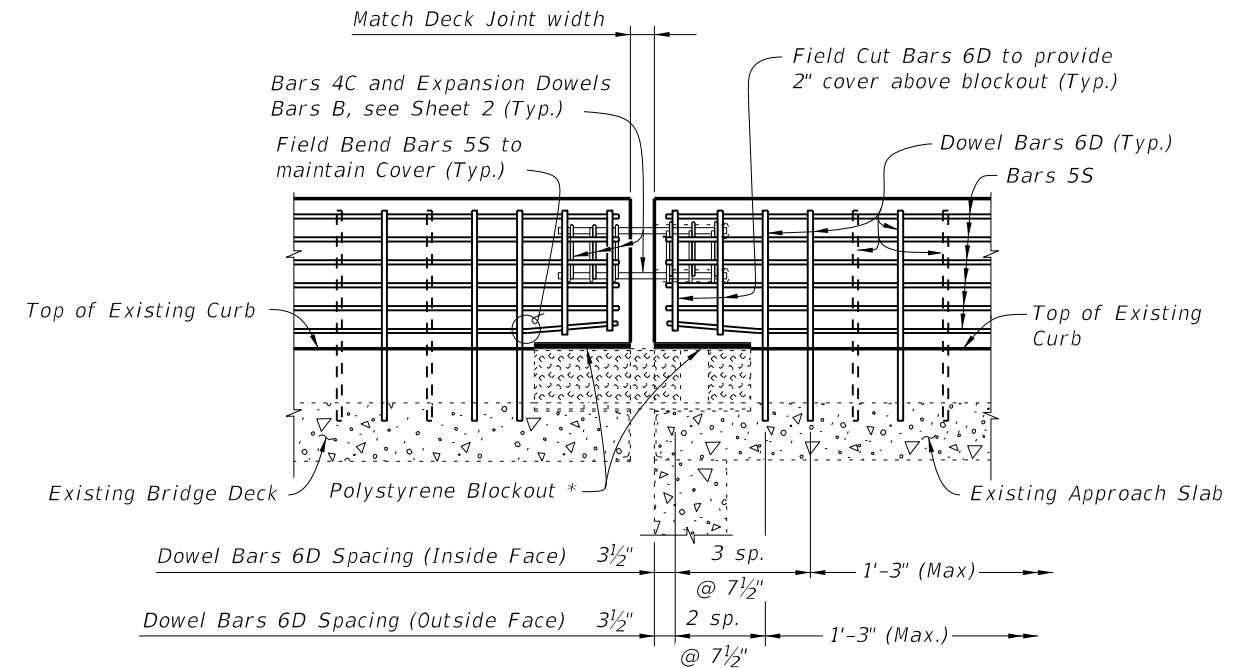

PARTIAL ELEVATION OF RAILING SHOWING FINGER/SLIDING PLATE JOINT AT BEGIN OR END BRIDGE - SCHEMES 2 THRU 5

* Place 1" thick polystyrene blockout over limits of bridge deck expansion joint full width to the end of the Traffic Railing to allow for thermal movement. Seal Forms to prevent mortar leakage into the expansion joint.

BARRIER DELINEATOR SPACING	
Distance - Edge of Travel Lane to Face of Railing	Spacing (Ft.)
< 4'	40'
4' to 8'	80'
> than 8'	None Required

ESTIMATED TRAFFIC RAILING QUANTITIES			
ITEM	UNIT	QUANTITY	
		9" Curb	Increment
Concrete	CY/FT	0.064	0.003 per in. height
Reinforcing Steel	LB/FT	13.27	0.10 per in. length

(Quantities are based on a 9" curb, no curb cross slope and 1'-0" embedment length of Bars 6D. If the curb height or embedment length differs from that shown, increase or decrease quantity by the given per inch increment.)

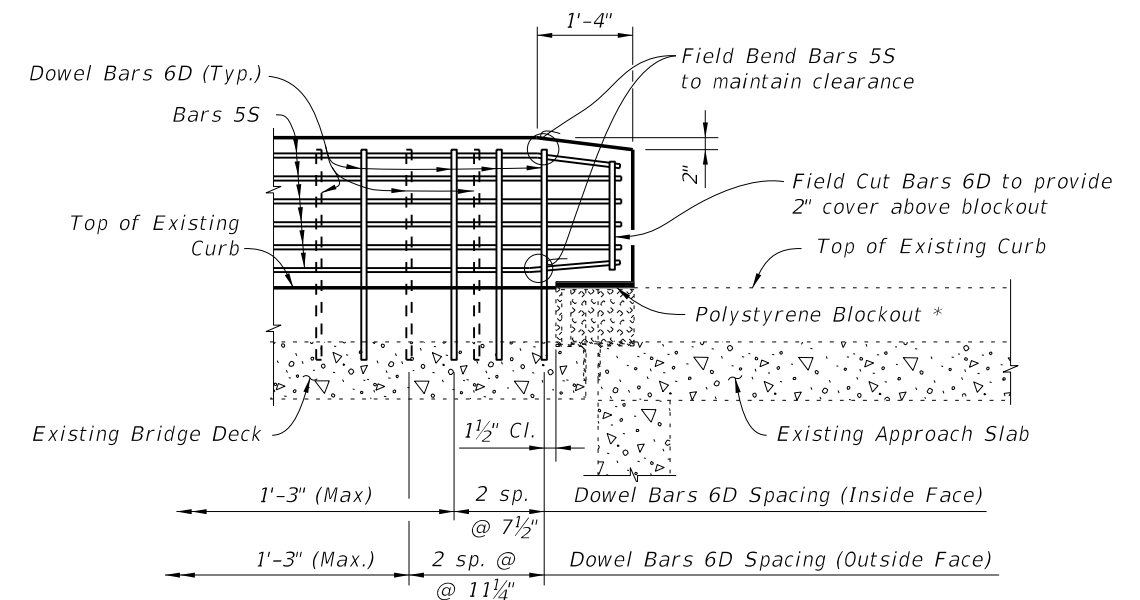

PARTIAL ELEVATION OF RAILING SHOWING FINGER/SLIDING PLATE JOINT AT BEGIN OR END BRIDGE - SCHEME 1 (Guardrail Transition not shown for clarity)

5/29/2014 11:32:27 AM

CONVENTIONAL REINFORCING STEEL BENDING DIAGRAM

BILL OF REINFORCING STEEL

MARK	SIZE	LENGTH	NOTE NOS.
A	4	AS REQD.	3
B	1" Ø	2'-0"	2 & 5
C	4	2'-0"	1, 2 & 3
D	6	AS REQD.	2 & 3
L	4	4'-1"	1 & 3
M	4	4'-3"	1 & 3
N	4	2'-5"	1 & 3
S	5	AS REQD.	2, 3 & 4

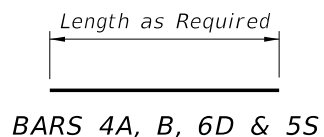

BARS 4A, B, 6D & 5S

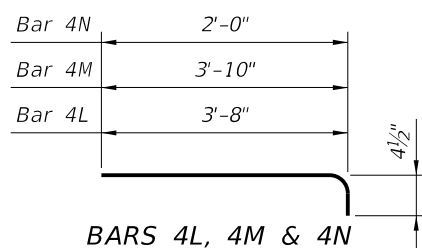

BARS 4L, 4M & 4N

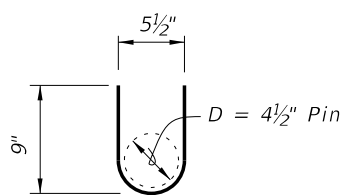

BARS 4C
(12 required per open joint)

REINFORCING STEEL NOTES:

- All bar dimensions in the bending diagrams are out to out.
- The reinforcement for the railing on a retaining wall shall be the same as detailed for a bridge deck.
- All reinforcing steel in the Vertical Face Retrofit Railing shall have a 2" minimum cover.
- Bars 5S may be continuous or spliced at the construction joints. Bar splices for Bars 5S shall be a minimum of 2'-0".
- Expansion Dowel Bars B shall be ASTM A36 smooth round bar and hot-dip galvanized in accordance with the Specifications.

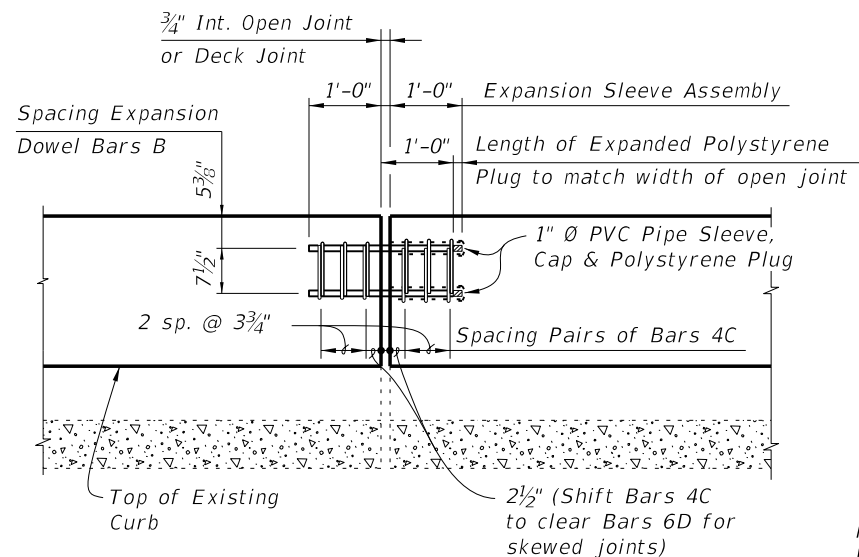

OPEN JOINT EXPANSION DOWEL DETAIL
(Railing Reinforcing Not Shown For Clarity)

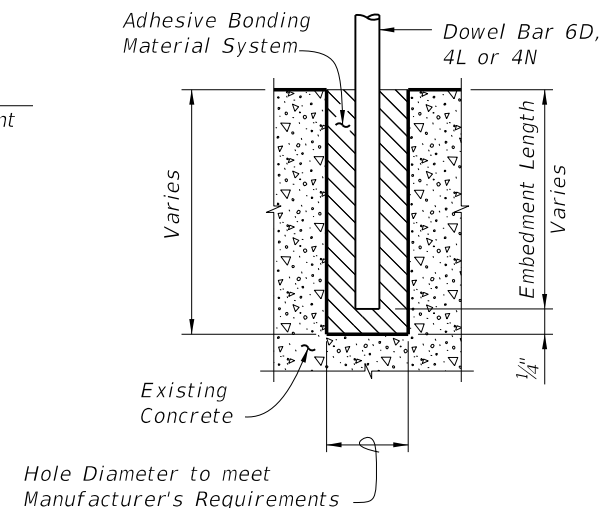

DOWEL DETAIL

Dowel Installation Note:
Shift dowel holes to clear if the existing reinforcement is encountered.

* 1/2" Preformed Joint Filler at top of Existing Curb shall extend beyond the joint material (Silicone, poured rubber, armored neoprene seal or sliding plates) as shown to prevent concrete intrusion during railing casting and shall be placed so as not to restrict in any way normal joint movement.

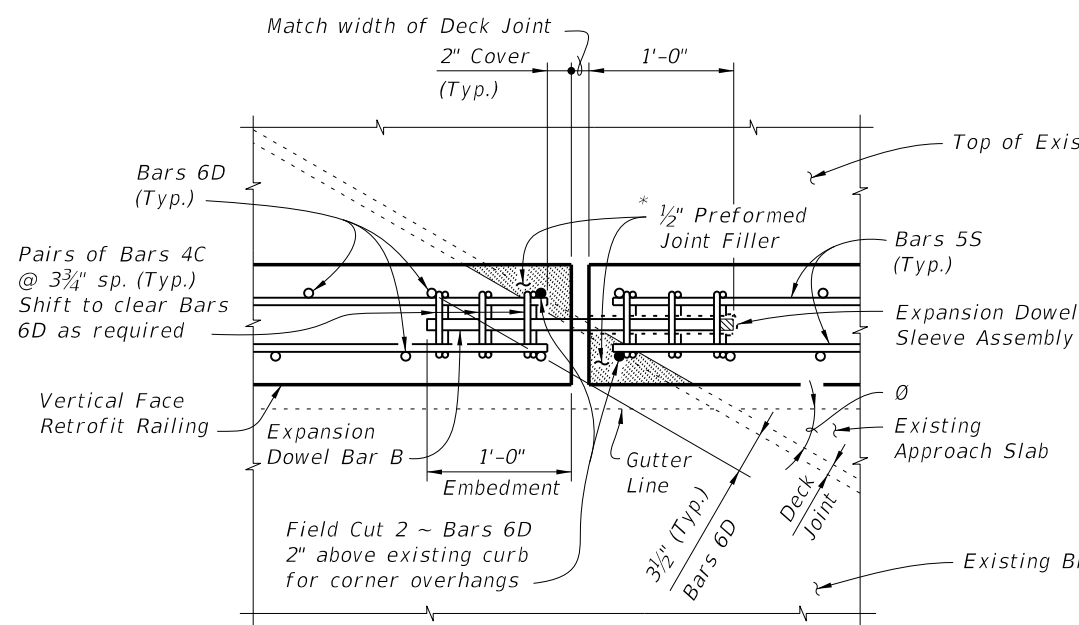

PARTIAL PLAN OF RAILING (SKEW ANGLE Ø LESS THAN 70°)

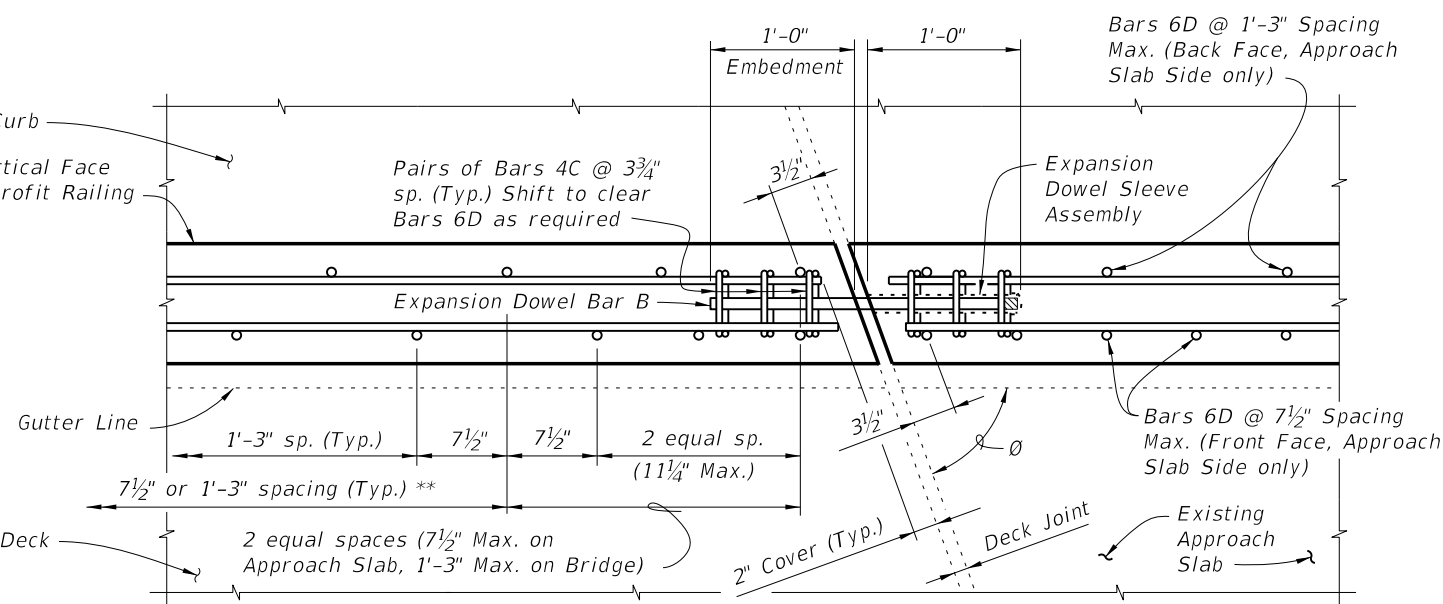

PARTIAL PLAN OF RAILING (SKEW ANGLE Ø = 70° OR GREATER)

SKEW DETAIL

5/29/2014 11:32:28 AM

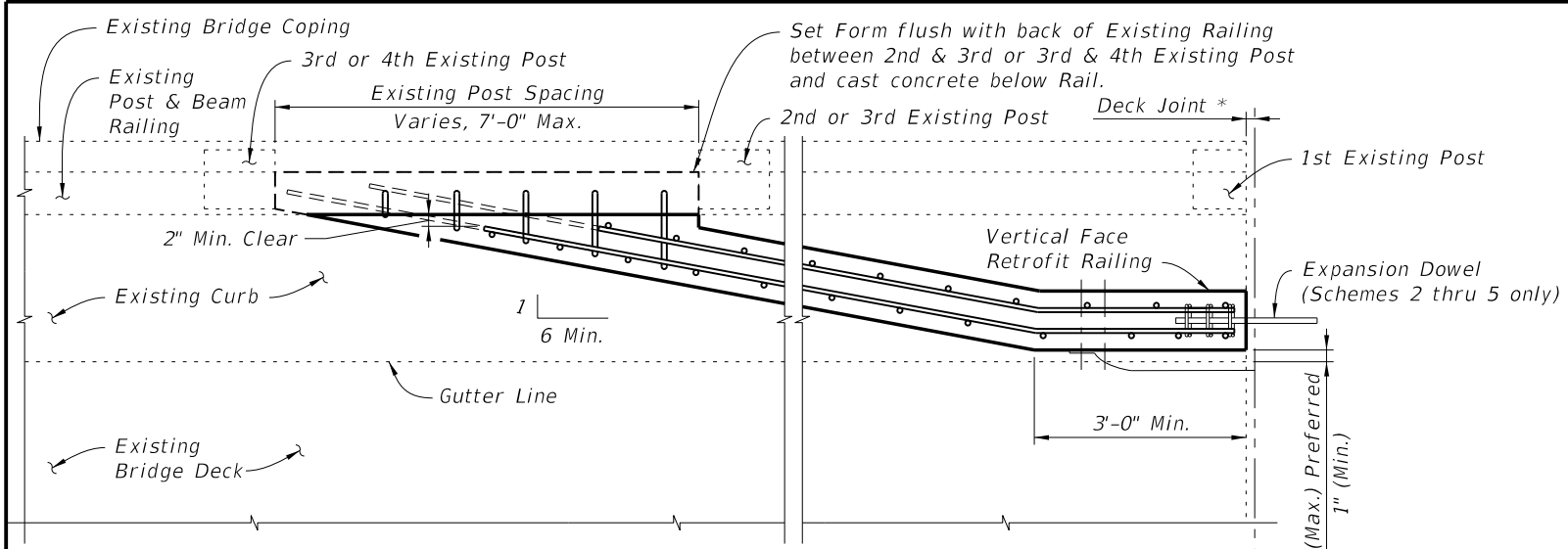

PARTIAL PLAN OF RAILING

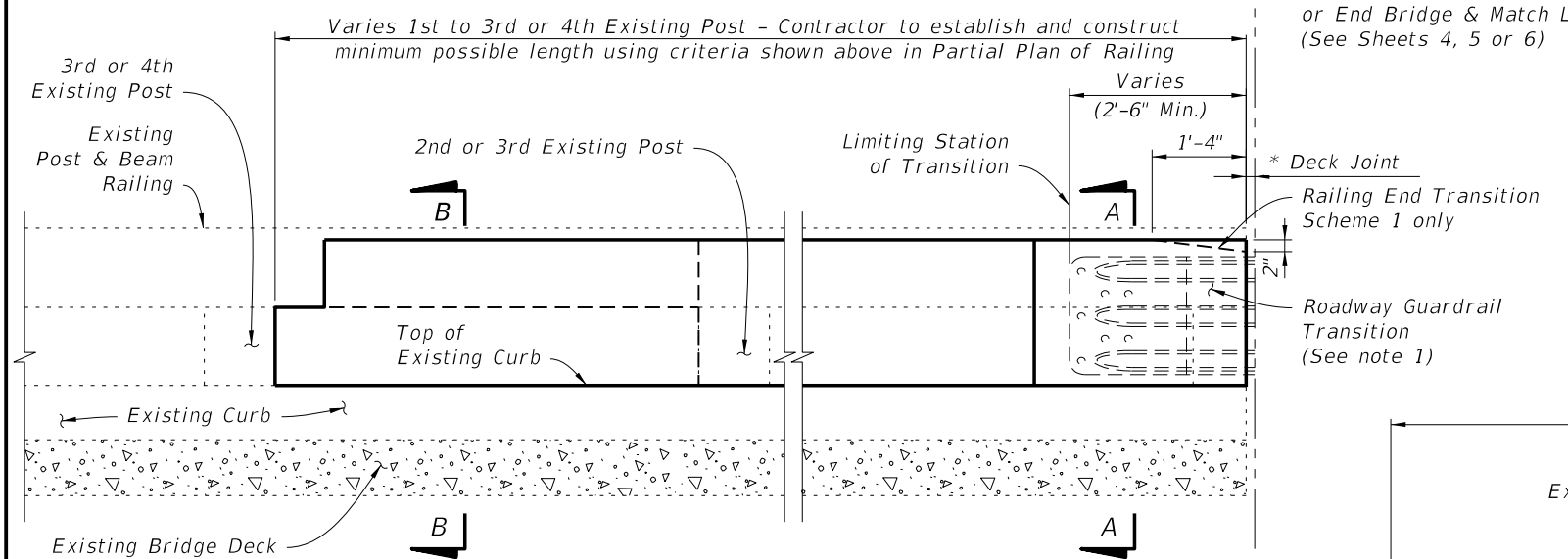

PARTIAL ELEVATION OF INSIDE FACE OF RAILING
(Expansion Dowel Assemblies & Bars 4C not shown for clarity)

TYPICAL TREATMENT OF RAILING ALONG BRIDGE

- NOTES:
1. On approach end provide a Roadway Guardrail Transition, Index No. 402 (as shown) or other site specific treatment. See Roadway Plans for limiting station of Roadway Guardrail Transition or other site specific treatment. If limiting station of Roadway Guardrail Transition is on the bridge, attach Thrie-Beam Terminal Connector to railing as shown above. If limiting station of Roadway Guardrail Transition is along the Wing Wall, see Schemes 2, 3, 4 or 5, Sheets 4, 5 and 6. On skewed bridges, if the skew along the deck joint extends across the width of the railing, the 2'-6" minimum dimension shall apply to both the front and back face of the railing. For treatment of trailing end see Roadway Plans.
 2. Field cut Bars 5S and Dowel Bars 6D to maintain clearance within Vertical Face Retrofit Railing.
 3. Where existing structure has been removed and not encased in new concrete; match adjoining areas and finish flat by grouting or grinding as required. Exposed existing reinforcing steel not encased in new concrete shall be burned off 1" below existing concrete and grouted over.

- * Non skewed deck joint shown, actual joint dimensions and orientation vary. For treatment at skewed deck joints see Skew Detail. Provide open Railing Joints at Deck Expansion Joint locations matching the dimension of the Deck Joint.
- ** Curb heights vary from 5" Min. to 1'-2" Max.
- ‡ Embedment - 1'-0" preferred with 2" Edge Distance or Bottom Clearance. 6" Min. if Edge Distance or Bottom Clearance is less than 2".

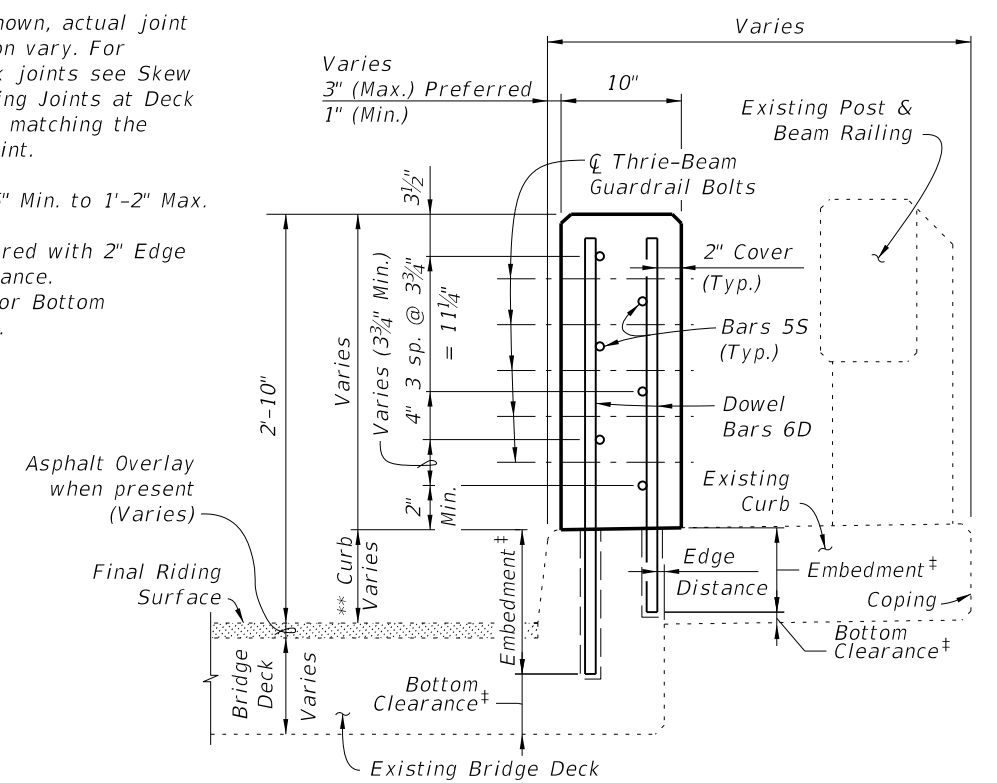

SECTION A-A
TYPICAL SECTION THRU RAILING ON BRIDGE DECK

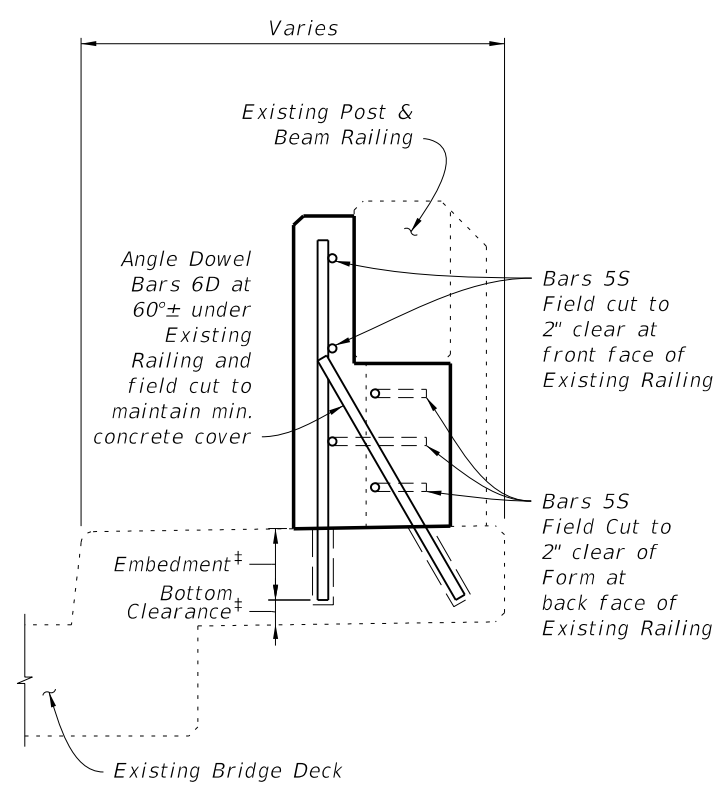

SECTION B-B

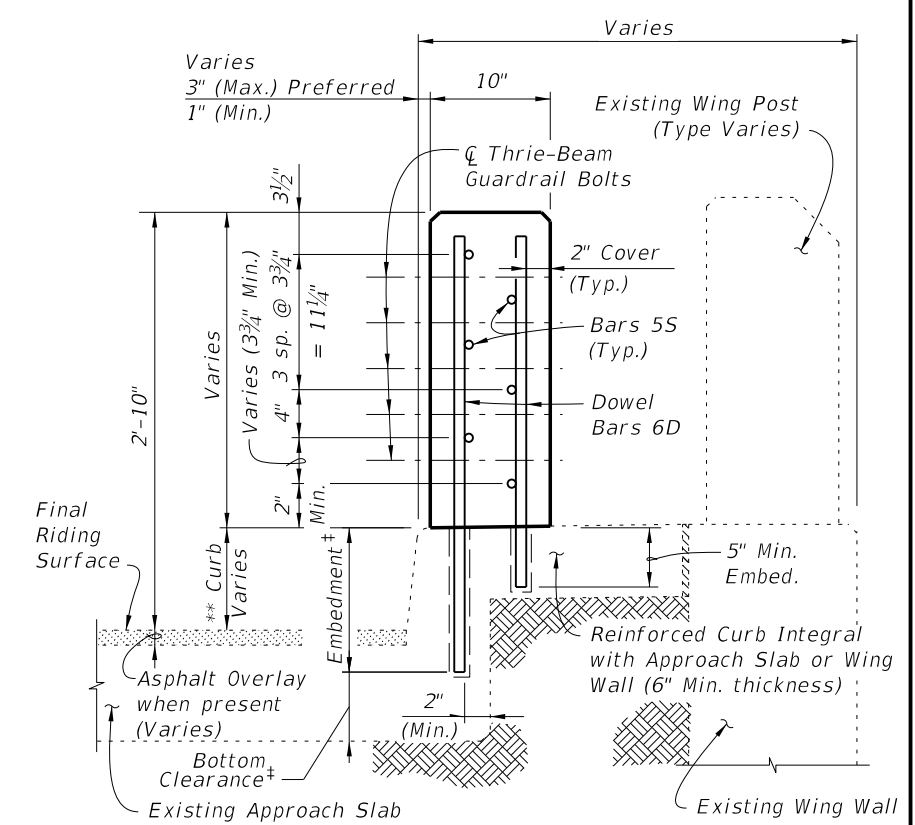

SECTION C-C
TYPICAL SECTION THRU RAILING ALONG APPROACH SLAB
(SCHEMES 2 AND 3 ONLY)

5/29/2014 11:32:29 AM

LAST REVISION 07/01/13	DESCRIPTION:		2015 DESIGN STANDARDS	GUARDRAIL TRANSITIONS - EXISTING POST & BEAM BRIDGE RAILINGS (WIDE CURBS)	INDEX NO. 405	SHEET NO. 3 of 6

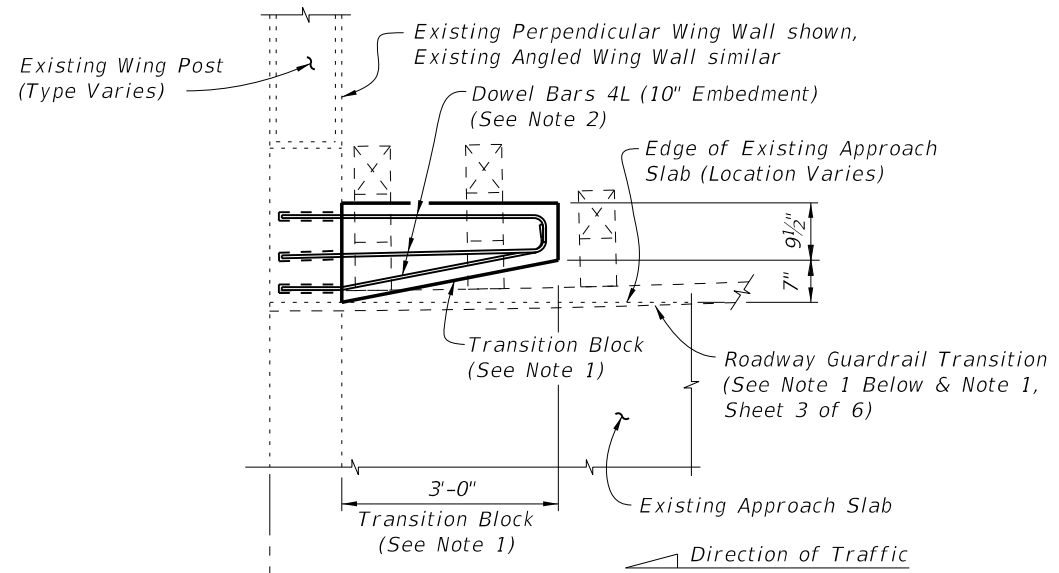

PARTIAL PLAN OF RAILING

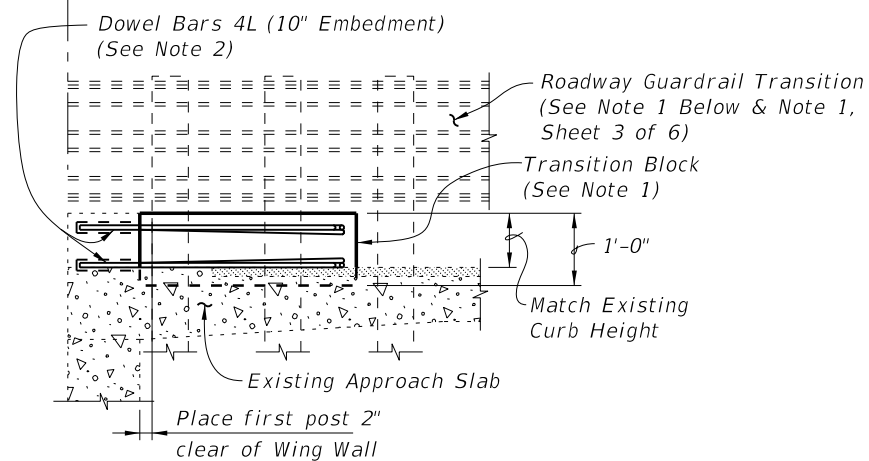

PARTIAL ELEVATION OF INSIDE FACE OF GUARDRAIL
(Existing Wing Post not shown for clarity)

SCHEME 1
RAILING END TREATMENT FOR PERPENDICULAR OR ANGLED WING WALLS

SCHEME 1 NOTES:

1. Provide Transition Block (as shown) or Curb if existing Approach Slab does not have a curb, see Roadway Plans. Shape and height of Transition Block or Curb shall match existing bridge curb. Railing End Transition and Transition Block may be omitted on trailing ends with no opposing traffic.
2. Field bend Dowel Bars 4L within Transition Block as required to maintain 2" top and side clearance and 3" bottom clearance.
3. If a Special Steel Guardrail Post is required for attachment to the top of a sloping Wing Wall, saw cut and remove a wedge shaped portion of the sloping Wing Wall as required to provide a level surface for post installation.

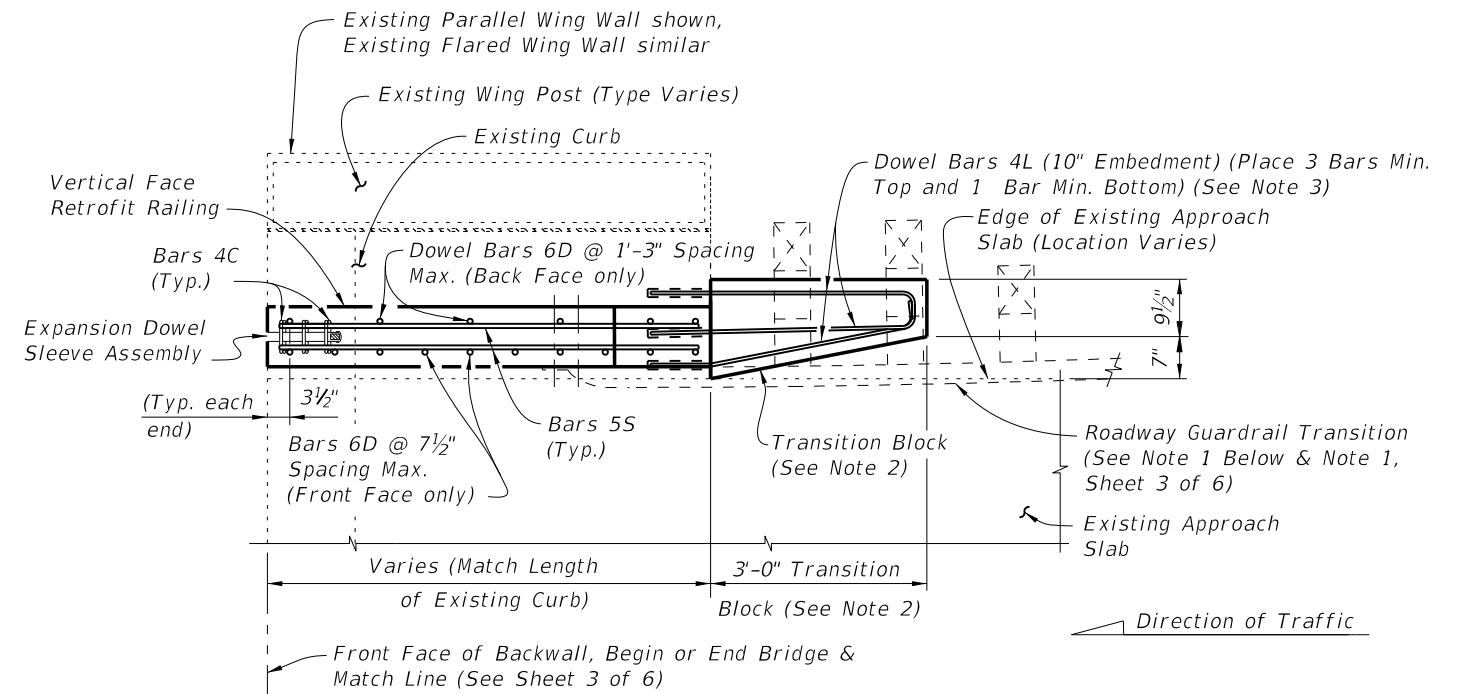

PARTIAL PLAN OF RAILING

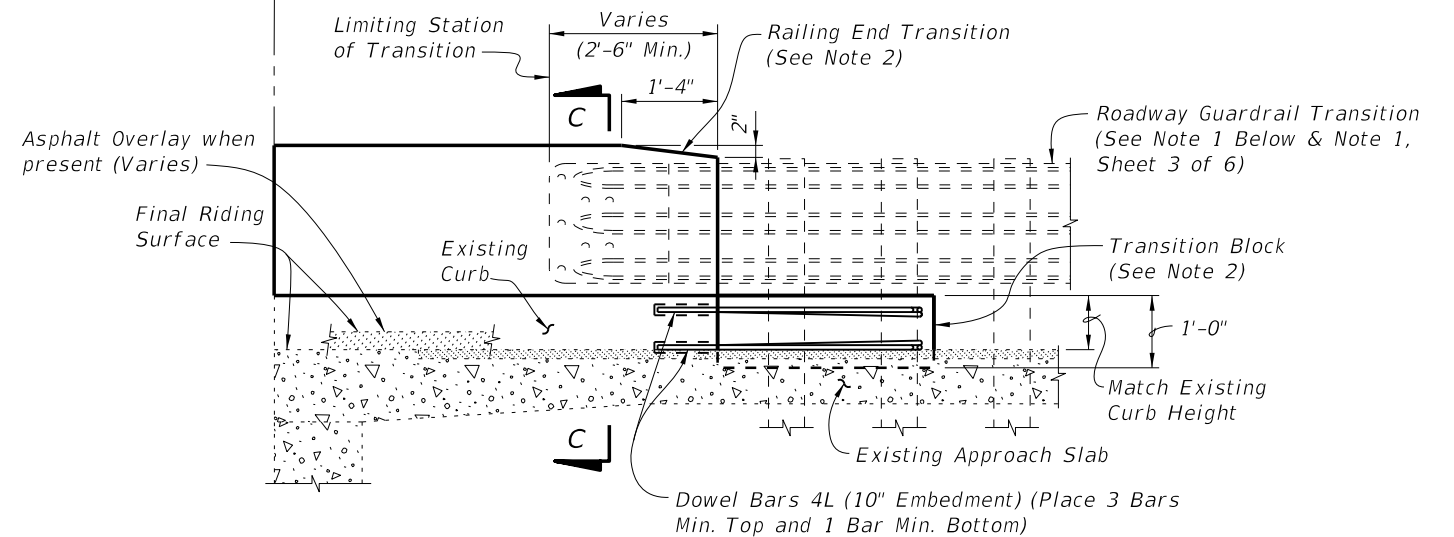

PARTIAL ELEVATION OF INSIDE FACE OF RAILING
(Existing Wing Post, Railing Reinforcing and Expansion Dowel Assemblies not shown for clarity)

SCHEME 2
RAILING END TREATMENT FOR PARALLEL CURBS

SCHEME 2 NOTES:

1. See Roadway Plans for limiting station of Roadway Guardrail Transition or other site specific treatment. If limiting station of Roadway Guardrail Transition is along the Wing Wall, attach Thrie-Beam Terminal Connector to railing as shown above. If limiting station of Roadway Guardrail Transition is on the bridge, see Sheet 3 of 6. On skewed bridges, if the skew along the deck joint extends across the width of the railing, the 2'-6" minimum dimension shall apply to both the front and back face of the railing.
2. Provide Transition Block (as shown) or Curb if existing Approach Slab Curb does not extend beyond end of existing End Bent Wing Wall, see Roadway Plans. Shape and height of Transition Block or Curb shall match existing bridge curb. Railing End Transition and Transition Block may be omitted on trailing ends with no opposing traffic.
3. Field bend Dowel Bars 4L within Transition Block as required to maintain 2" top and side clearance and 3" bottom clearance.

5/29/2014 11:32:30 AM

LAST REVISION 07/01/13	REVISION	DESCRIPTION:	 2015 DESIGN STANDARDS	GUARDRAIL TRANSITIONS - EXISTING POST & BEAM BRIDGE RAILINGS (WIDE CURBS)	INDEX NO. 405	SHEET NO. 4 of 6
---------------------------	----------	--------------	---	--	------------------	---------------------

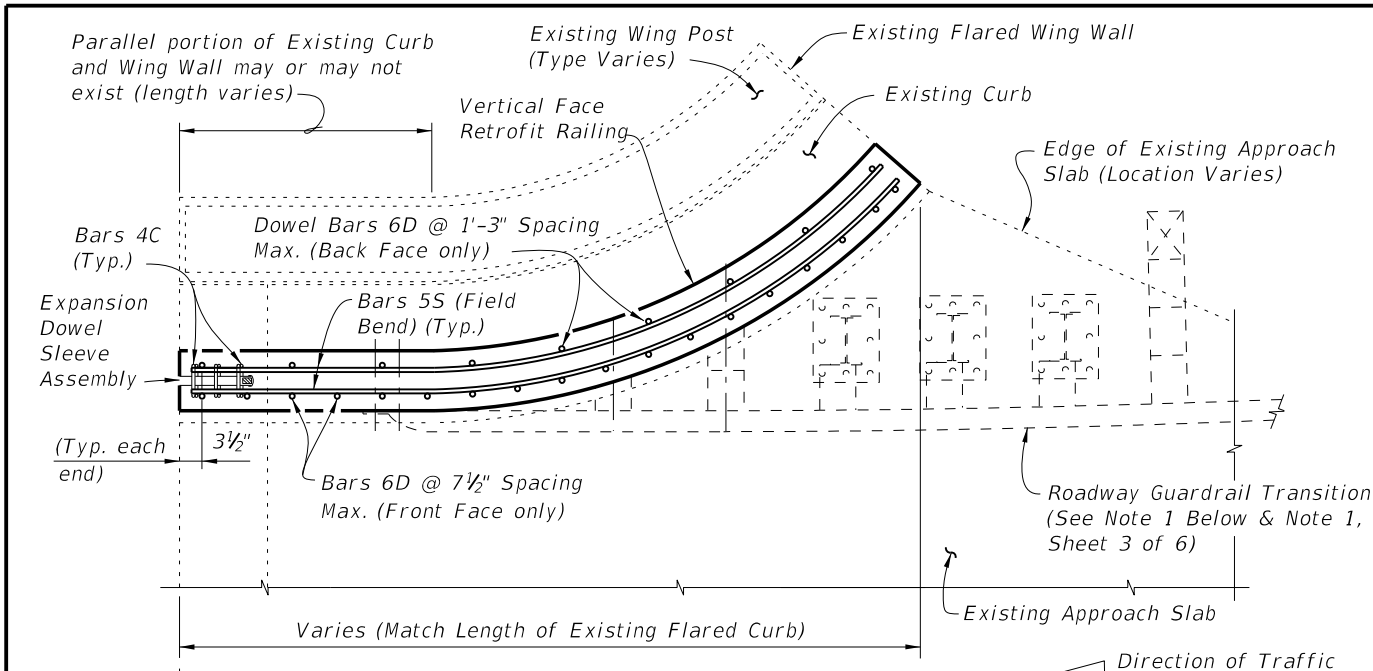

PARTIAL PLAN OF RAILING

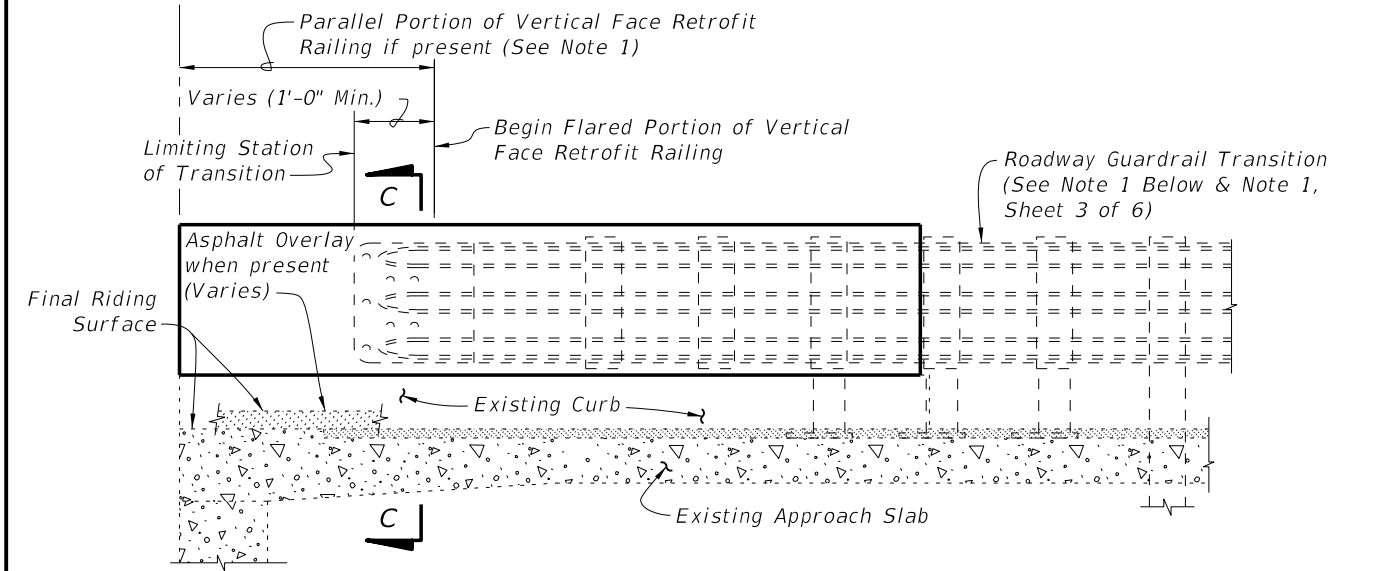

PARTIAL ELEVATION OF INSIDE FACE OF RAILING

(Existing Wing Post, Railing Reinforcing and Expansion Dowel Assemblies not shown for clarity)

SCHEME 3
RAILING END TREATMENT FOR FLARED CURBS

SCHEME 3 NOTE:

1. See Roadway Plans for limiting station of Roadway Guardrail Transition or other site specific treatment. If limiting station of Roadway Guardrail Transition is along the Wing Wall, attach Thrie-Beam Terminal Connector to railing as shown above. If limiting station of Roadway Guardrail Transition is on the bridge, see Sheet 3 of 6.

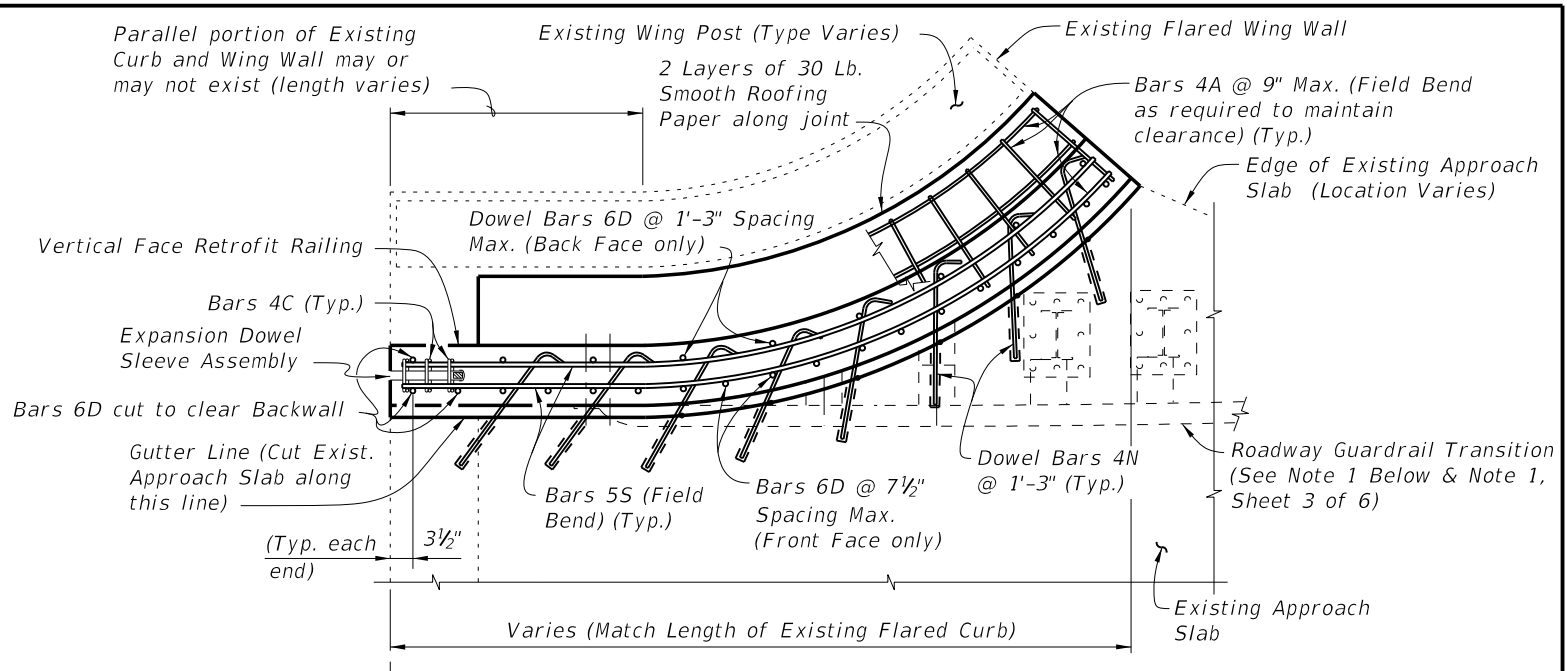

PARTIAL PLAN OF RAILING

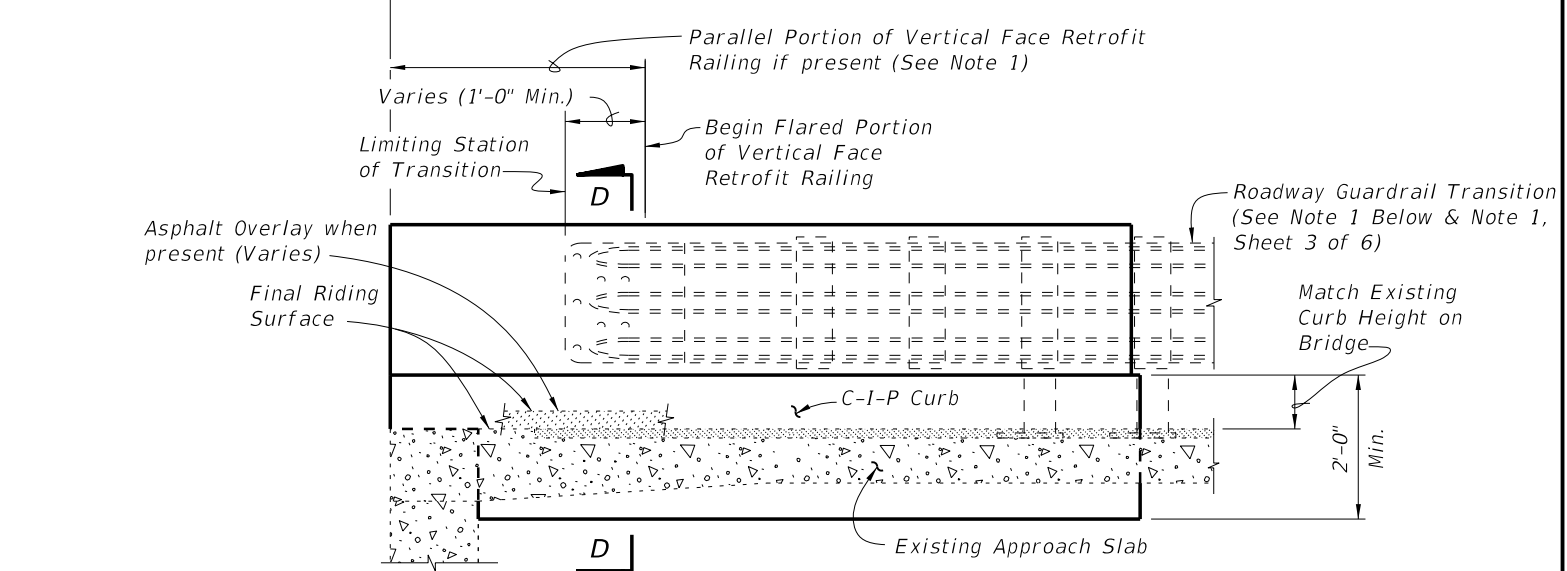

PARTIAL ELEVATION OF INSIDE FACE OF RAILING

(Existing Wing Post, Railing Reinforcing and Expansion Dowel Assemblies not shown for clarity)

SCHEME 4
RAILING END TREATMENT FOR FLARED CURBS

SCHEME 4 NOTES:

1. See Roadway Plans for limiting station of Roadway Guardrail Transition or other site specific treatment. If limiting station of Roadway Guardrail Transition is along the Wing Wall, attach Thrie-Beam Terminal Connector to railing as shown above. If limiting station of Roadway Guardrail Transition is on the bridge, see Sheet 3 of 6.
2. Dowel Bars 4N may be installed on a maximum angle of 45° to the cut edge of the Approach Slab as shown to facilitate drilling of holes and installation of bars.
3. At the Contractor's option, along the length of the Approach Slab curb that is to be replaced, Dowel Bars 6D may be cast in with the new section of curb as shown or they may be installed in drilled holes in the new section of curb using an Adhesive Bonding Material System with a 1'-0" minimum embedment.

5/29/2014 11:32:31 AM

LAST REVISION 07/01/13	REVISION	DESCRIPTION:	 2015 DESIGN STANDARDS	GUARDRAIL TRANSITIONS - EXISTING POST & BEAM BRIDGE RAILINGS (WIDE CURBS)	INDEX NO. 405	SHEET NO. 5 of 6
---------------------------	----------	--------------	------------------------------	--	------------------	---------------------

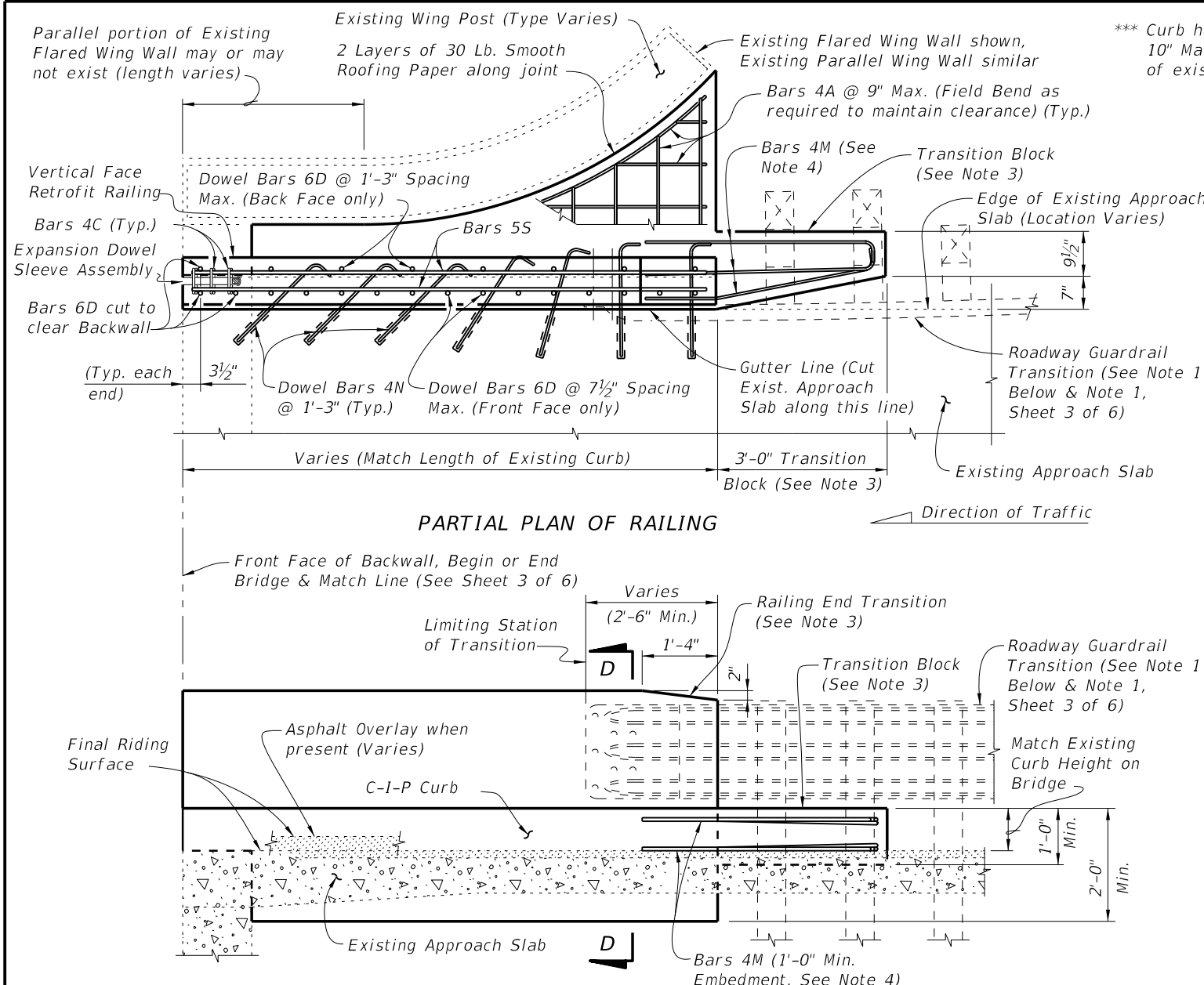

*** Curb heights vary from 5" Min. to 10" Max. Match height and shape of existing curb on bridge.

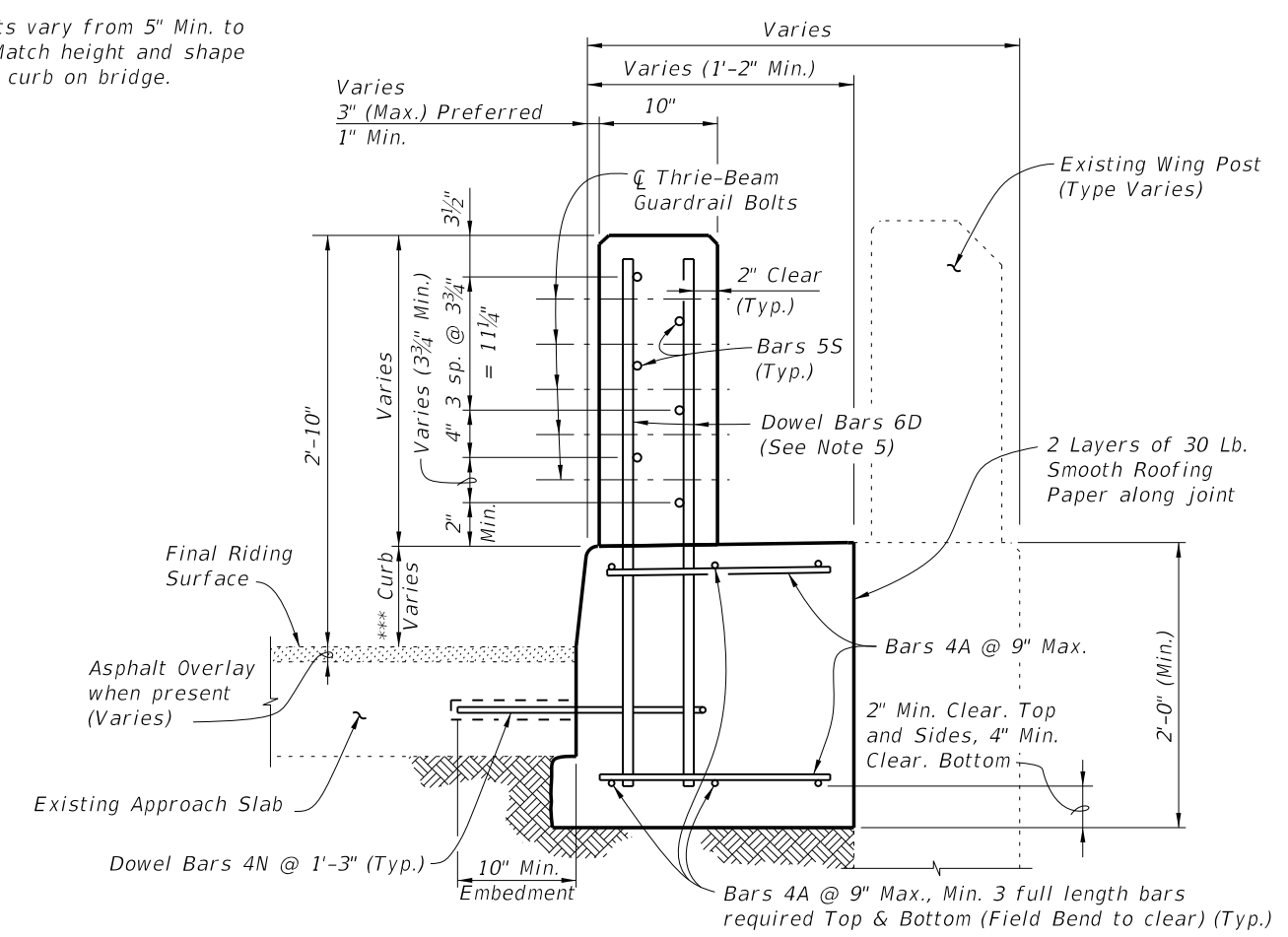

SECTION D-D
TYPICAL SECTION THRU RAILING ALONG APPROACH SLAB
(SCHEME 4 SHOWN, SCHEME 5 SIMILAR)

PARTIAL ELEVATION OF INSIDE FACE OF RAILING
(Existing Wing Post, Railing Reinforcing and Expansion Dowel Assemblies not shown for clarity)

SCHEME 5
RAILING END TREATMENT FOR PARALLEL CURBS

SCHEME 5 NOTES:

1. See Roadway Plans for limiting station of Roadway Guardrail Transition or other site specific treatment. If limiting station of Roadway Guardrail Transition is along the Wing Wall, attach Thrie-Beam Terminal Connector to railing as shown above. If limiting station of Roadway Guardrail Transition is on the bridge, see Sheet 3 of 6.
2. Dowel Bars 4N may be installed on a maximum angle of 45° to the cut edge of the Approach Slab as shown to facilitate drilling of holes and installation of bars.
3. Provide Transition Block (as shown) or Curb if existing Approach Slab Curb does not extend beyond end of existing End Bent Wing Wall, see Roadway Plans. Shape and height of Transition Block or Curb shall match existing bridge curb. Railing End Transition and Transition Block may be omitted on trailing ends with no opposing traffic.
4. Field bend Dowel Bars 4M within Transition Block as required to maintain 2" top and side clearance and 3" bottom clearance.
5. At the Contractor's option, along the length of the Approach Slab curb that is to be replaced, Dowel Bars 6D may be cast in with the new section of curb as shown or they may be installed in drilled holes in the new section of curb using an Adhesive Bonding Material System with a 1'-0" minimum embedment.

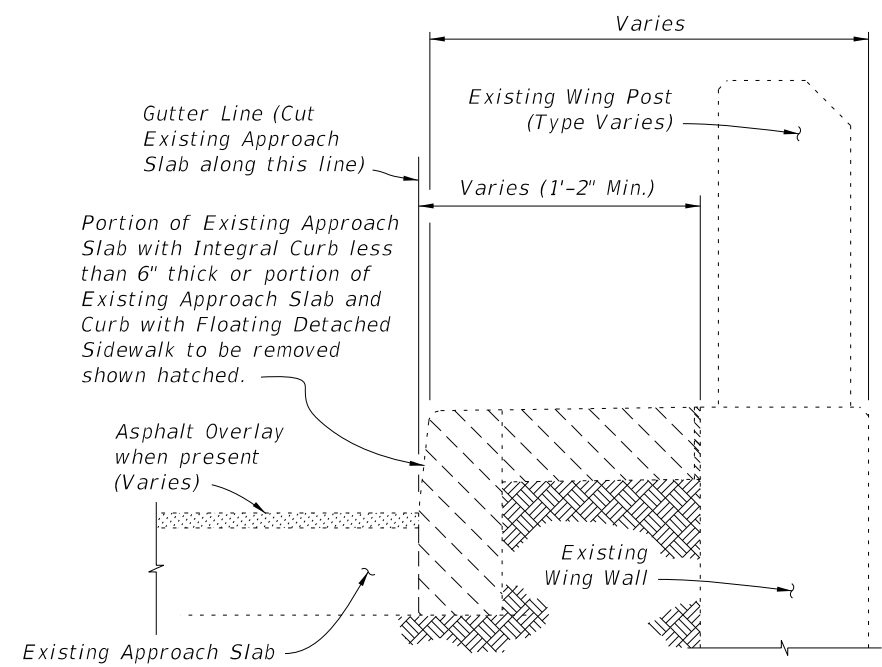

TYPICAL SECTION THRU EXISTING APPROACH SLAB AND END BENT WING WALL SHOWING LIMITS OF REMOVAL
(SCHEMES 4 AND 5 ONLY)

5/29/2014 11:32:32 AM

LAST REVISION 07/01/13	REVISION	DESCRIPTION:	 2015 DESIGN STANDARDS	GUARDRAIL TRANSITIONS - EXISTING POST & BEAM BRIDGE RAILINGS (WIDE CURBS)	INDEX NO. 405	SHEET NO. 6 of 6
---------------------------	----------	--------------	---	--	------------------	---------------------