

VALLEY GUTTER

\* When used on high side of roadways, the cross slope of the gutter shall match the cross slope of the adjacent pavement. The thickness of the lip shall be 6", unless otherwise shown on plans.

▣ Rotate entire section so that gutter cross slope matches slope of adjacent circulating roadway pavement.

For use adjacent to concrete or flexible pavement. For details depicting usage adjacent to flexible pavement, see Sheet 2. Expansion joint, preformed joint filler and joint seal are required between curb & gutter and concrete pavement only, see Sheet 2.

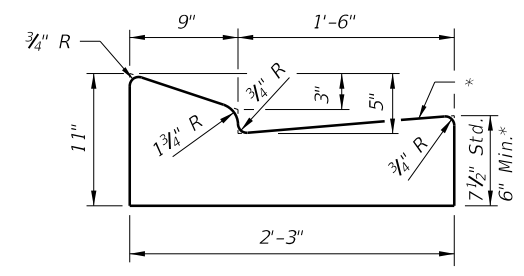

TYPE E

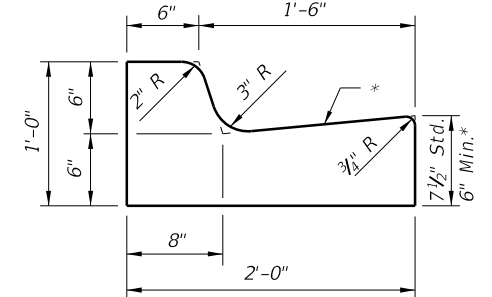

TYPE F

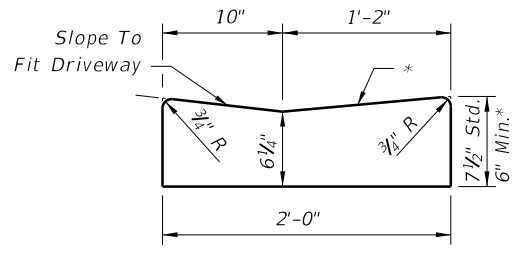

Note: To be paid for as parent curb.

DROP CURB

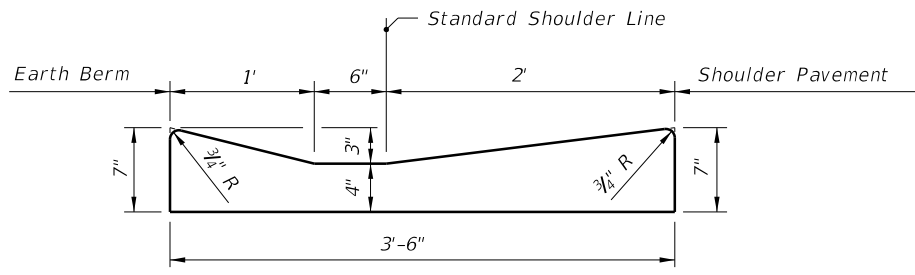

SHOULDER GUTTER

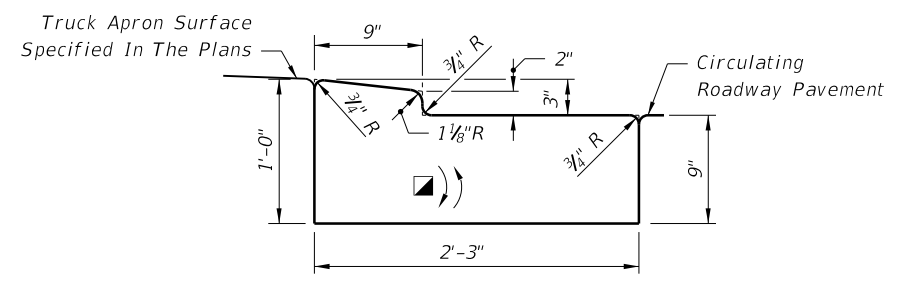

TRAFFIC BEARING SECTION FOR USE IN ROUNDABOUT CENTRAL ISLAND CONSTRUCTION  
TYPE RA

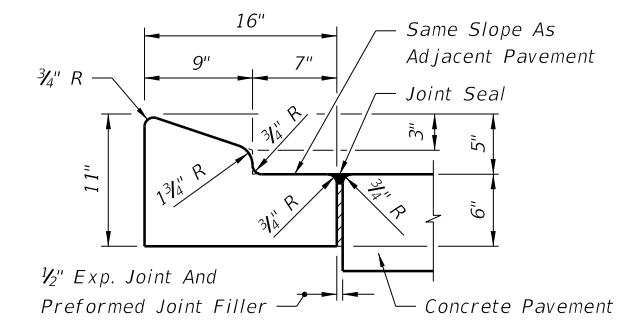

TYPE A

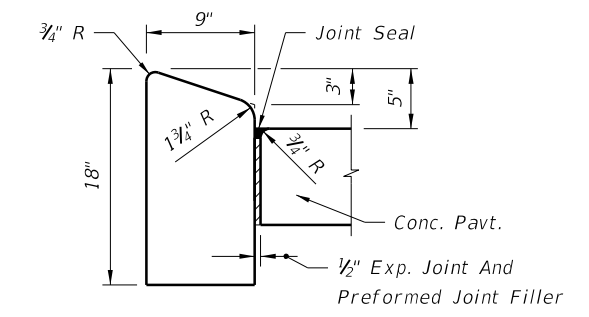

TYPE B

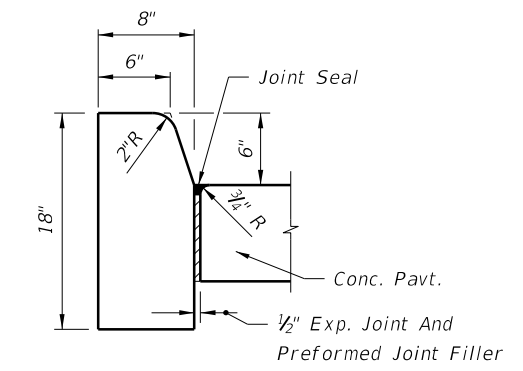

TYPE D

Note: For use adjacent to concrete or flexible pavement, concrete shown. Expansion joint, preformed joint filler and joint seal are required between curbs and concrete pavement only, see Sheet 2.

CONCRETE CURB

CONCRETE CURB AND GUTTER

5/20/2014 2:58:13 PM

|                           |          |              |                              |                        |                  |                     |
|---------------------------|----------|--------------|------------------------------|------------------------|------------------|---------------------|
| LAST REVISION<br>07/01/00 | REVISION | DESCRIPTION: | <br>2015<br>DESIGN STANDARDS | CURB & CURB AND GUTTER | INDEX NO.<br>300 | SHEET NO.<br>1 of 2 |
|---------------------------|----------|--------------|------------------------------|------------------------|------------------|---------------------|

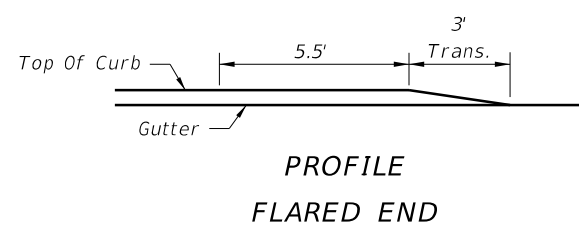
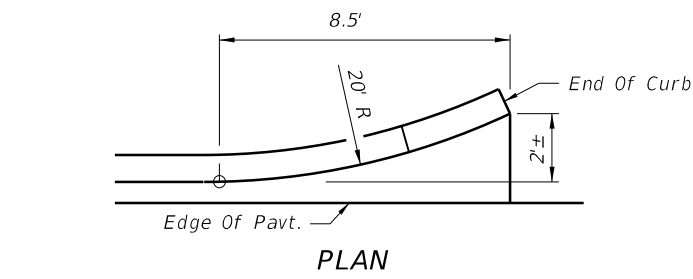

CURB TYPE A

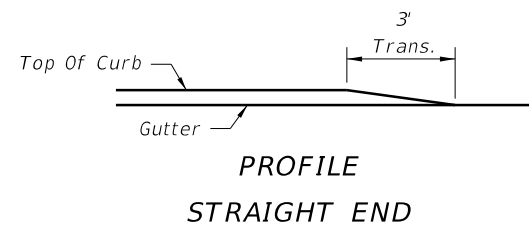
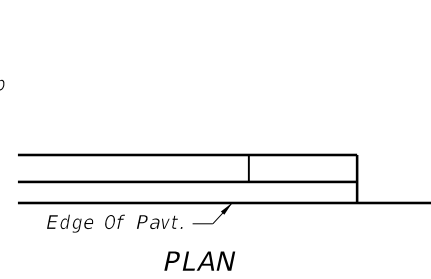

PROFILE STRAIGHT END

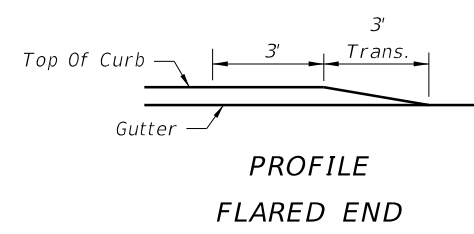
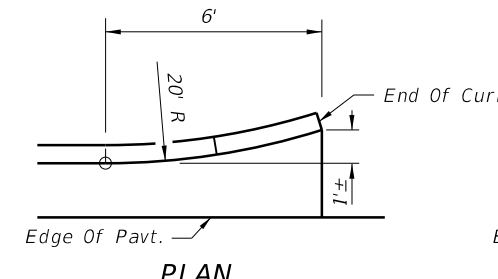

PROFILE FLARED END

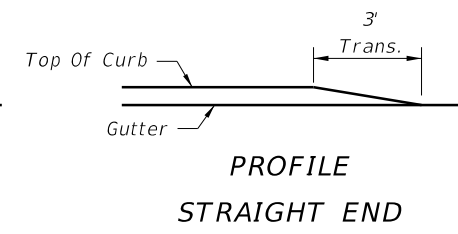
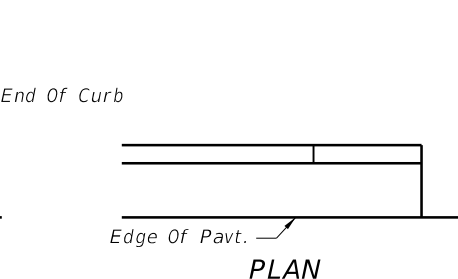

PROFILE STRAIGHT END

CURB AND GUTTER TYPES E & F

CURB AND GUTTER ENDINGS

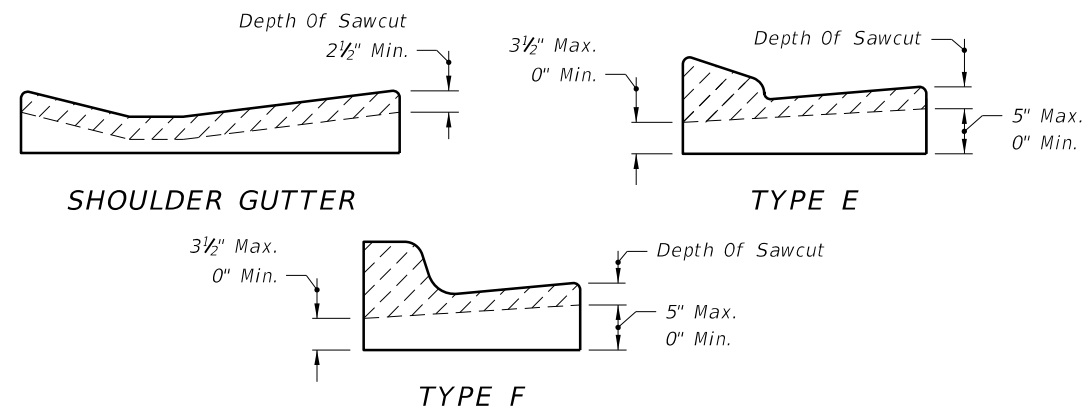

SHOULDER GUTTER

TYPE E

TYPE F

Sawcuts should be avoided within valley gutter and within curb and gutter endings.  
**CONTRACTION JOINT IN CURB AND GUTTER**

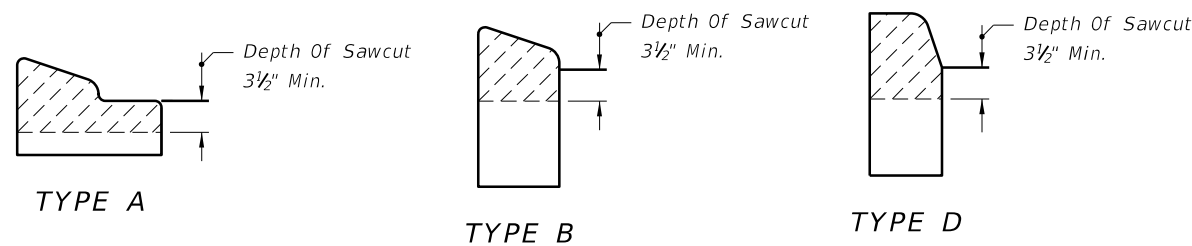

TYPE A

TYPE B

TYPE D

CONTRACTION JOINT IN CURB

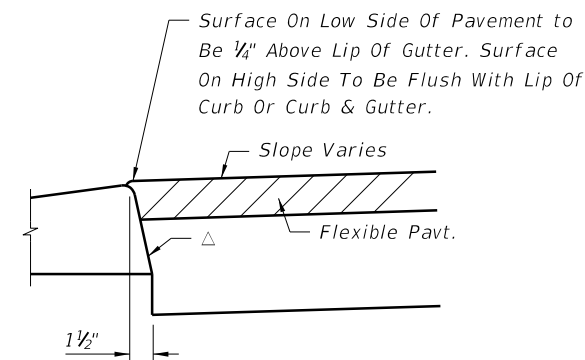

△ Applies to both high and low sides of pavement, low side shown.  
 Applies to shoulder gutter only where adjoining traffic lanes.

CURB AND GUTTER AND TYPE A CURB ADJACENT TO FLEXIBLE PAVEMENT

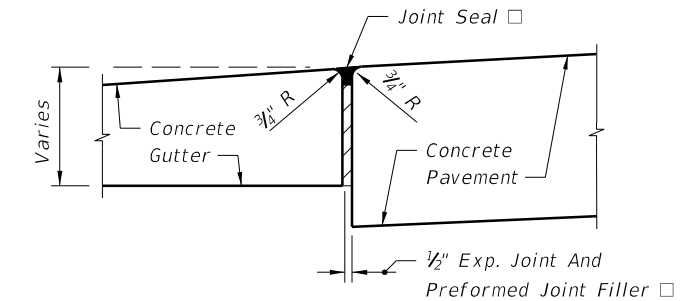

□ Applies to both high and low sides of pavement, low side shown.

EXPANSION JOINT BETWEEN GUTTER AND CONCRETE PAVEMENT

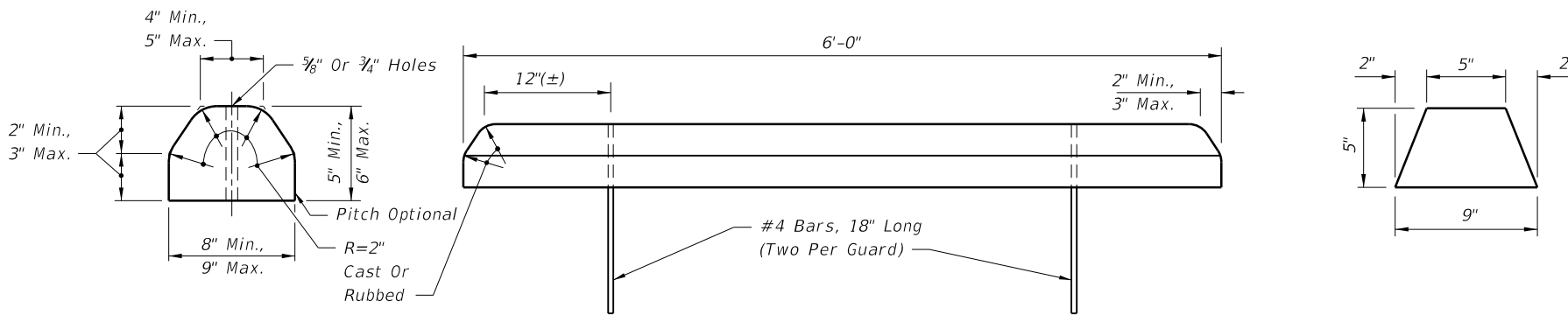

CONCRETE BUMPER GUARD

ASPHALTIC CONCRETE CURB

GENERAL NOTES

1. For curb, gutter and curb & gutter provide 1/8" - 1/4" contraction joints at 10' centers (max.). Contraction joints adjacent to concrete pavement on tangents and flat curves are to match the pavement joints, with intermediate joints not to exceed 10' centers. Curb, gutter and curb & gutter expansion joints shall be located in accordance with Section 520 of the Standard Specifications.
2. Ends of Curbs Types B and D shall transition from full to zero heights in 3'.

5/20/2014 2:58:14 PM

|               |              |
|---------------|--------------|
| LAST REVISION | DESCRIPTION: |
| 07/01/00      |              |