

PREFORMED POLYETHYLENE ALTERNATE

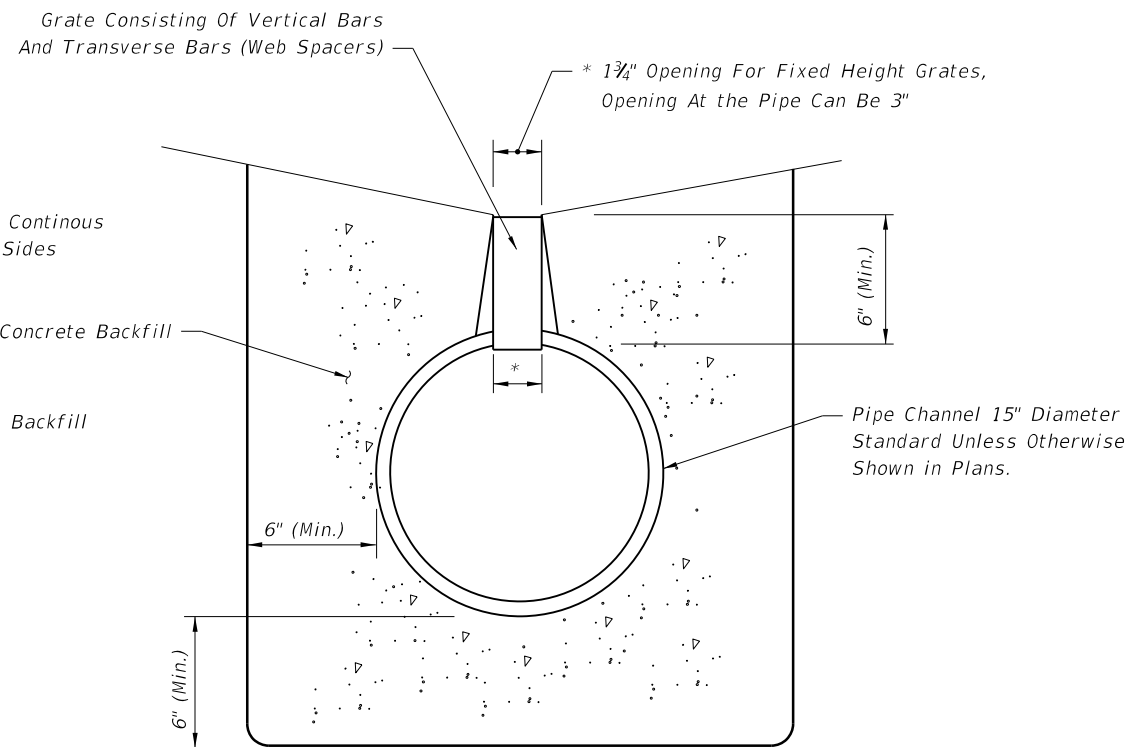

ROUND ALTERNATE

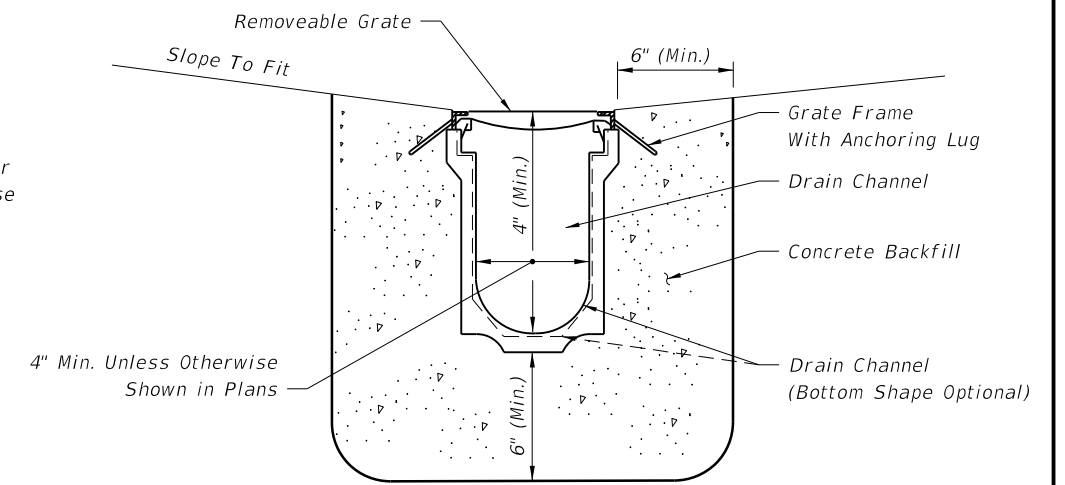

PREFORMED CHANNEL WITH REMOVABLE GRATE

SEE SHEET 2 FOR TYPICAL LOCATIONS

SEE SHEET 2 FOR TYPICAL LOCATIONS

TYPE I (NON-REMOVABLE GRATE)

TYPE II

GENERAL NOTES

1. Trench drain is intended for use in gutters and driveways as shown on the typical locations on Sheet 2. Type I is intended for use in Type E, F and drop curbing, and adjacent to traffic separators and standard barrier walls. The width of the channel grate for Type I Trench Drain shall be 1 3/4" throughout varying the depth of the channel neck. Type II may also be used in those locations if an independent laboratory certifies that the grating used has an open area equal to at least 0.27 square feet per linear foot. Type II is primarily intended for use in valley gutter across driveway openings and drop curbing; Type I may also be used in those locations. The width of the channel grate for Type II Trench Drain shall be the same as the width of the channel. The linear slope or gradient for Type II may be manufactured by varying the depth of the channel. Trench Drain shall not be placed in pedestrian paths unless ADA compliant grates are used.
2. Unless shown in the plans, outlet pipes and preformed channel inverts shall be sloped 0.6% or steeper toward the outlet regardless of the surface slope.
3. Trench drain may be stubbed directly into drainage structures, or outlet pipes may be used to connect trench drain to drainage structures.
4. A cleanout port compatible with the manufactured system shall be provided for Type I drains at the upstream end and at intervals not to exceed 50 feet. The cleanout port shall provide an opening 6" to 10" wide (transverse to the trench drain length) and 18" to 24" long. Where cleanouts are placed adjacent to raised curb or separator, the curb or separator shall be formed around the cleanout. The cleanout shall have a removable load resistant cover or grate.
5. Trench excavation must allow for a minimum of 6" of concrete to be placed under and alongside the trench drain channel system. Concrete backfill shall meet the requirements of Section 347 of the Standard Specifications. At the end of all units (Type I or II), the concrete backfill shall extend 6" minimum past the end of the drain opening.
6. Transverse bars for Type I Trench Drain shall be spaced 4" to 6" on center.
7. Whenever the work disturbs existing conditions or work already completed, restore the same to its original condition in every detail. All such repair and replacement shall meet the approval of the Engineer.
8. Payment to be made under the contract unit price for Trench Drain, LF.

DESIGN NOTES

1. Where placed adjacent to reinforced concrete barrier wall or median barrier wall, the designer shall detail in the plans the position of the drain relative to the barrier wall to avoid conflicts with the barrier wall footing. See Index No. 410.
2. The designer shall identify the following in the plans:
 - (a) The type of drain at each location.
 - (b) The begin and end locations of the Trench Drain.
 - (c) The location of the outlet pipe if the Trench Drain is not stubbed directly into a drainage structure.
 - (d) The design flow (Q) for the Trench Drain must be shown on the plans.
3. Capture efficiency for Type I Trench Drain may be computed using the equations for slotted drain in FHWA's HEC 12 & 22. Grate Type I and Type II must have at least 30% open area.
4. Round pipe alternate is available in 12, 18, 24 and 36 inch.
5. Type II Preformed Channel with integral anchoring lugs are applicable.

5/20/2014 2:16:19 PM

LAST REVISION 07/01/10	REVISION	DESCRIPTION:	 2015 DESIGN STANDARDS	TRENCH DRAIN	INDEX NO. 206	SHEET NO. 1 of 2
---------------------------	----------	--------------	--	---------------------	-------------------------	----------------------------

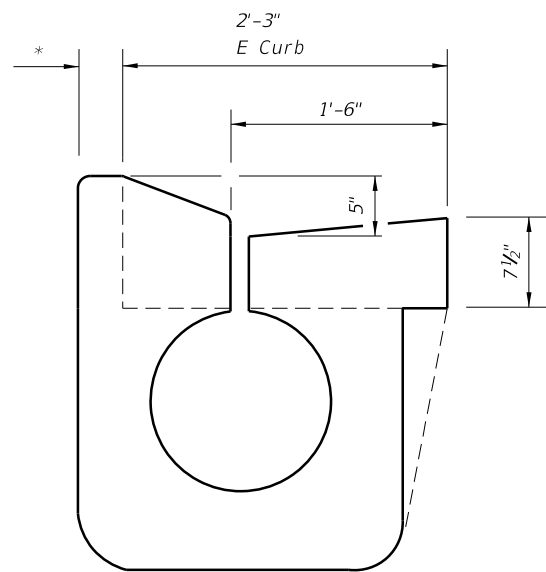

WITHIN TYPE E CURB

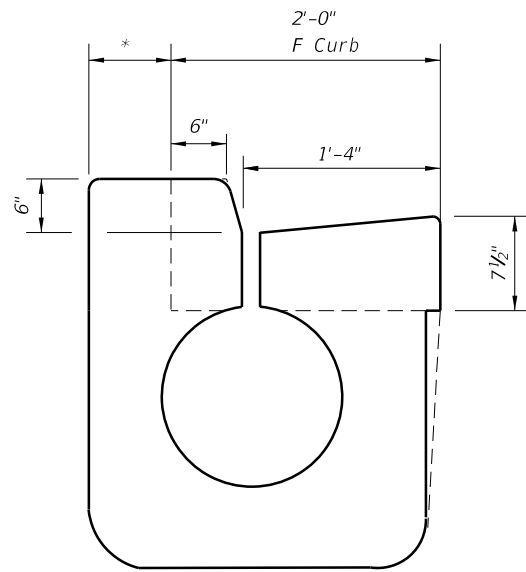

WITHIN TYPE F CURB

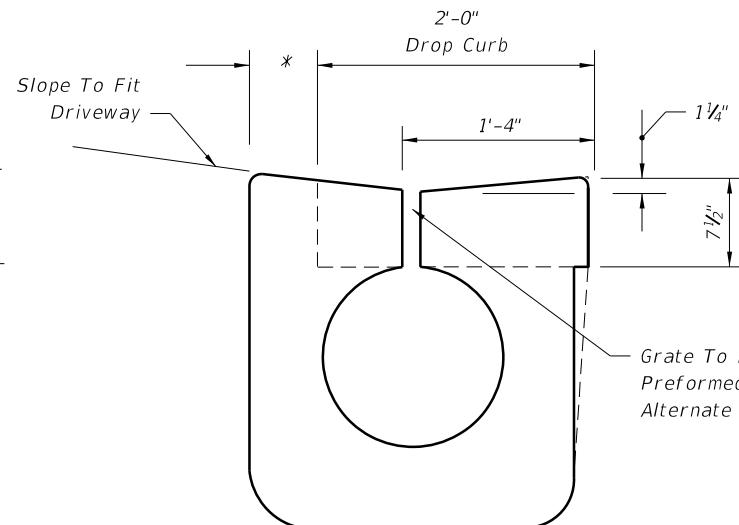

WITHIN DROP CURB

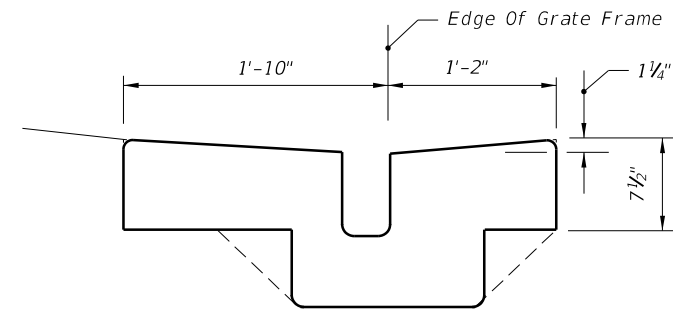

WITHIN VALLEY GUTTER

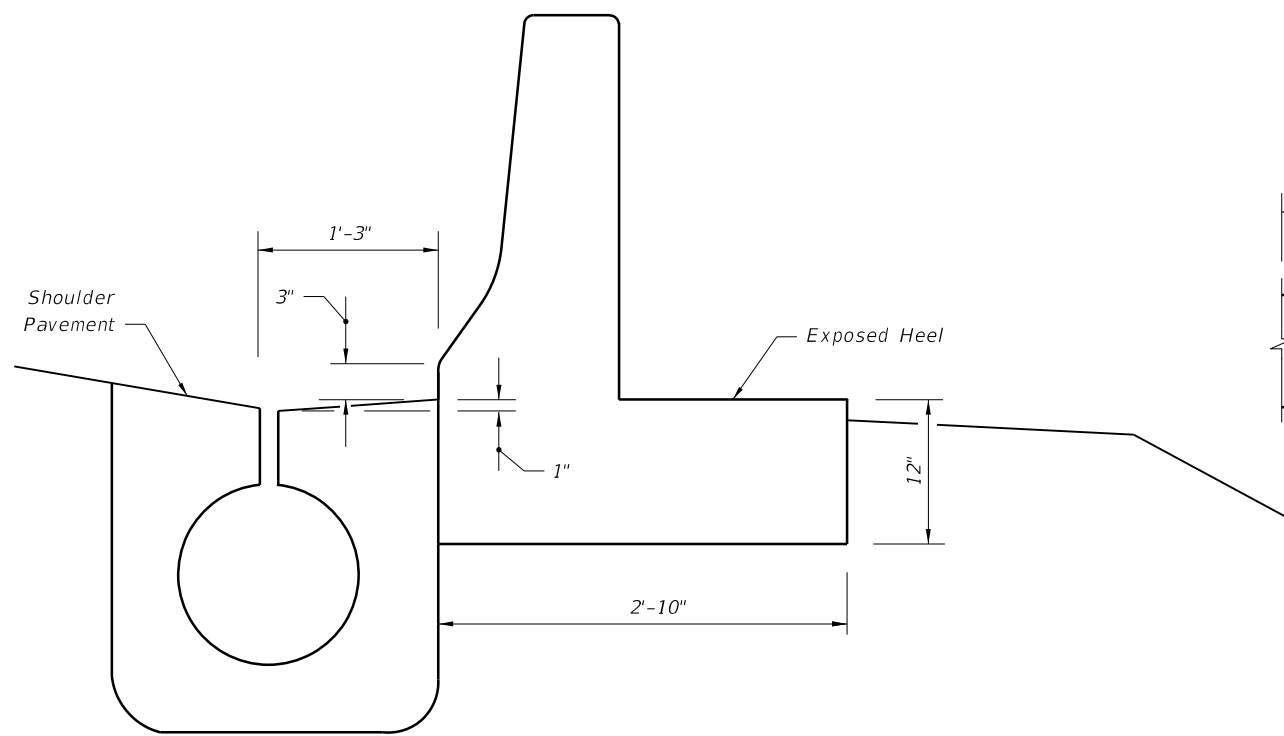

ADJACENT TO SHOULDER BARRIER WALL

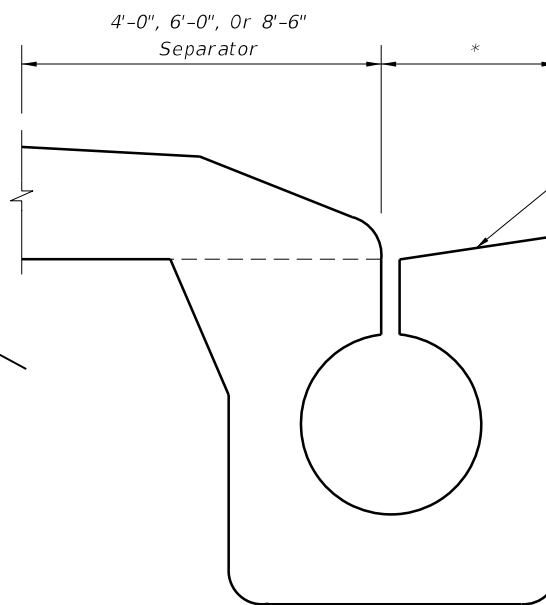

ADJACENT TO TRAFFIC SEPARATOR

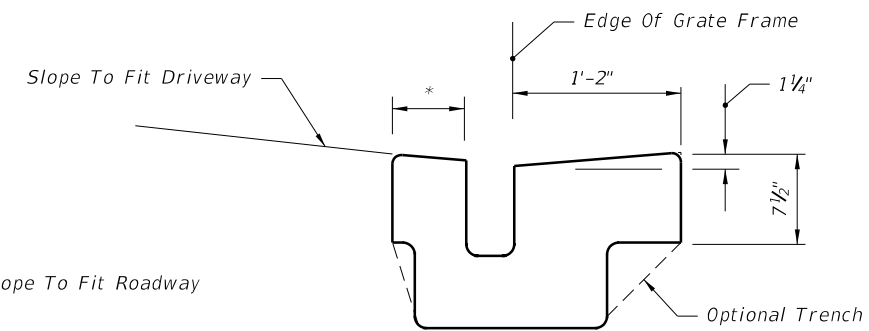

WITHIN DROP CURB
TYPICAL LOCATIONS FOR TYPE II

ROUND PIPE ALTERNATE SHOWN, BUT PREFORMED POLYETHYLENE ALTERNATE ACCEPTABLE

TYPICAL LOCATIONS FOR TYPE I

* As Necessary To Provide 6" Of Concrete
On This Side Of Drain

5/20/2014 2:16:19 PM

LAST REVISION 07/01/04	DESCRIPTION:	 2015 DESIGN STANDARDS	TRENCH DRAIN	INDEX NO. 206	SHEET NO. 2 of 2
---------------------------	--------------	--	--------------	------------------	---------------------