

DETAIL OF CONNECTION BETWEEN BARRIER UNITS

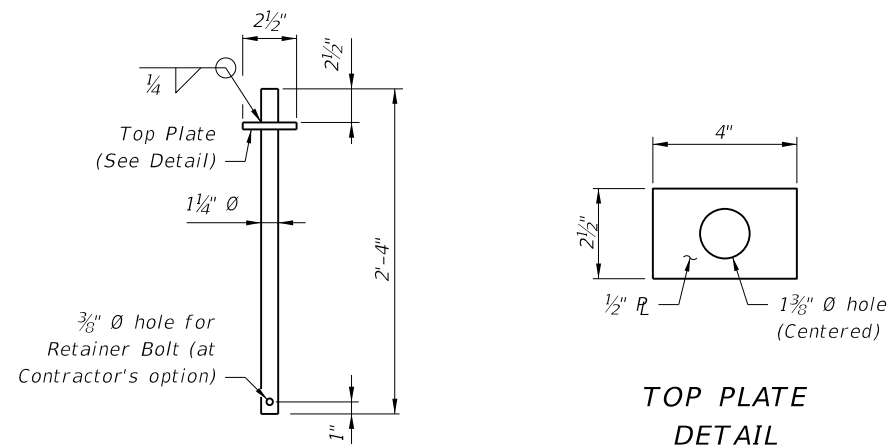

CONNECTION PIN DETAIL

NOTES FOR ALL INSTALLATIONS:

- LIMITATION OF USE:** This Temporary Concrete Barrier System is intended for work zone traffic control and other temporary applications. It shall not be used for permanent traffic railing construction unless specifically permitted by the Plans. Except as shown for the Back Filled Roadway Installations, the Barrier Units must be installed on a flexible pavement (asphalt) or rigid pavement (concrete) surface as shown with a cross slope of 1:10 or flatter. Except as shown for transition installations, Type K Barrier Units are not intended to be bolted down or staked down in locations where they can be impacted from the back side.
- HANDLING:** At no time shall the Barrier Units be lifted or moved by use of Bars 6D that extend from the ends of the units. Approximate weight of one unit equals 2.7 tons.
- SURFACE PREPARATION:** Except as shown for the Back Filled Roadway Installations, remove all grass, debris, loose dirt and sand from the pavement, bridge deck or Asphalt Pad surface within the barrier footprint just prior to placement of the Barrier Units.
- OFFSET TO TRAVELWAY:** Offset shall meet requirements as shown on sheet 1 of Index 415.
- CONNECTION PIN ASSEMBLY:** Steel for Connection Pin and Top Plate assemblies shall be in accordance with ASTM A36 or ASTM A709 Grade 36. Nondestructive testing of welds shall not be required. At the Contractor's option, a 3/8" diameter hole may be provided at the bottom of the Connection Pin, as shown, for the installation of a vandal resistance bolt.
- CONNECTION PIN INSTALLATION:** Initially set Barrier Units by using a 3 3/8" wooden block between ends of adjacent units. Install Connection Pin between adjacent Barrier Units as shown, then pull newly placed Barrier Unit away from adjacent Barrier Unit to remove slack between Connection Pin and Bars 6D (except as shown on Sheet 5). Barrier Units shall not be used unconnected.
- DELINEATION:** Mount Barrier Delineators on top of Barrier Units that are used as traffic barriers along travel ways in work zones. Space the Barrier Delineators at 50' centers in alignment transitions, 100' centers on horizontal curves and 200' centers on tangent alignments.
- REUSE OF UNITS:** Barrier Units may be reused provided they have the structural integrity and surface qualities of new units. Do not use Barrier Units without Marking Plates.
- MAINTENANCE:** Deflection space shall be kept clear of any grass, construction debris, stockpiled materials, equipment, and objects.
- REUSE OF CONNECTION PINS:** Connection pins may be reused if they have the structural integrity of new pins.
- INSTALLATIONS ON CURVED ALIGNMENTS:** The details presented in these Standards are shown for installations on tangent alignments. Details for horizontally curved alignments are similar.
- TRANSITIONS:** Transitions are required between freestanding, bolted down, staked down and back filled Type K Barrier installations, see Sheet 8 for transition requirements and details. Transitions are also required between installations of Type K Barrier and other types of temporary barrier, see Index No. 415 for transition requirements and details. Splices and transitions are required between installations of Type K Barrier and permanent Bridge or Roadway Traffic Railings, see Sheets 9 through 13 for transition requirements and details. Transitions are required between installations of Type K Barrier and Proprietary (QPL) Barrier Systems, See Sheets 14 and 15 for transition requirements and details.
- PAYMENT:** Barrier Units for work zone traffic control and other temporary applications shall be paid for under the contract unit price for Barrier Wall (Temporary) (F&I) (Type K), LF. Any relocation of the Barrier Units required for the project shall be paid for under the contract unit price for Barrier Wall (Temporary) (Relocate) (Type K), LF. The Contractor shall furnish Barrier Units except when the Plans stipulate the availability of Department owned units. Regardless of unit source the Contractor shall furnish all hardware and shall be responsible for all handling including loading, transport, unloading, stockpiling, installation, removal and return. Unless otherwise noted on the Plans, the Barrier Units shall become the property of the Contractor and shall be removed from the site prior to acceptance of the completed project.

NOTES FOR THRIE BEAM GUARDRAIL SPLICE INSTALLATIONS:

- THRIE-BEAM GUARDRAIL:** Provide Thrie-Beam Guardrail for splices in accordance with AASHTO M 180, Type II (Zinc coated) and as follows:
Two panels per splice (One panel per side) of Class B (10 Gauge), or
Four panels per splice (Two nested panels per side) of Class A (12 Gauge).
Guardrail panel length shall be 12'-6". Provide and install all other associated metallic guardrail components (Terminal Connectors, Shoulder Bolts, Hex Bolts and Nuts, Filler Plates, etc.) in accordance with Index No. 400.
Install five Guardrail Anchor Bolts at each end of each splice in any of the standard seven anchor bolt holes in the Thrie-Beam Terminal Connector.
If reinforcing steel is encountered when drilling holes for Guardrail Anchor Bolts in Type K Barrier Units, shift Thrie-Beam Terminal Connector so as to clear reinforcing steel within the given tolerances or select a different bolt hole to use. Do not drill or cut through reinforcing steel within Type K Barrier Units. Drilling or cutting through reinforcing steel within permanent concrete traffic railings is permitted. Do not drill or cut through utilities or conduits within permanent concrete traffic railings.
- GUARDRAIL OFFSET BLOCKS:** Provide and install timber Offset Blocks meeting the material requirements of Index No. 400. Field trim Offset Blocks as required for proper fit. Utilize Offset Blocks as shown and required in order to prevent bending or kinking of Thrie-Beam Guardrail panels.
- CONCRETE FOR FILLING TAPERED TRAFFIC RAILING TOES:** Provide concrete for filling tapered toes of Traffic Railings as shown meeting the material requirements of Specification Section 346, any Class, or a commercially available prebagged concrete mix (3000 psi minimum compressive strength). Sampling, testing, evaluation and certification of the concrete in accordance with Specification Section 346 is not required. Saturate with water the surfaces upon and against which the concrete fill will be placed prior to placing concrete. Place and finish concrete fill using forms or by hand methods to the general configurations shown so as to provide a smooth shape transition between the Type K Barrier and the adjacent traffic railing. A low slump is desirable if placing and finishing concrete by hand methods. Cure the concrete fill by application of a curing compound, or by covering with a wet tarp or burlap for a minimum of 24 hours. Completely remove the concrete fill upon relocation or removal of the Type K Temporary Concrete Barrier.

C:\projects\standards\roadway\00400-s\sr\00414-04D5R.dgn 3/14/2014 4:00:31 PM rd960fm

LAST REVISION	DESCRIPTION: Note #7: Removed Type C Steady Burn Lights and replaced with Barrier Delineators and removed reference to Index 600. Note #13: Removed Type C Steady Burn Lights payment information.	 FDOT 2014 DESIGN STANDARDS	TYPE K TEMPORARY CONCRETE BARRIER SYSTEM	INDEX NO. 414	SHEET NO. 4 of 15
---------------	--	--	---	-------------------------	-----------------------------