

TYPE 1

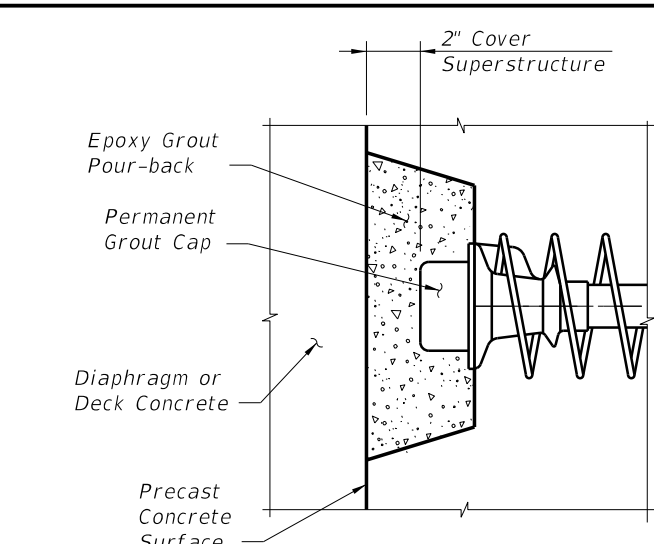

TYPE 2

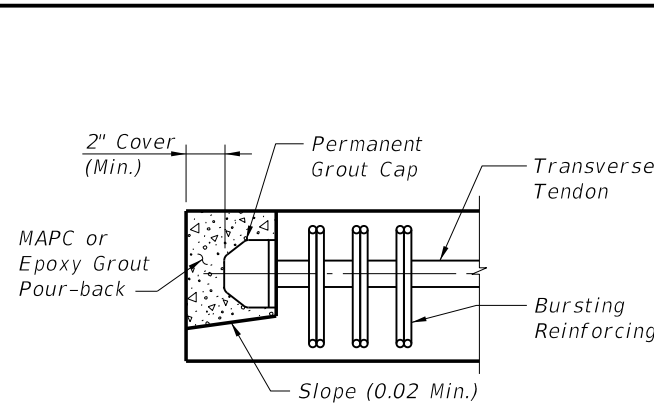

TYPE 7

- Type 7 Notes:  
 1. Traffic or Pedestrian/Bicycle Railing not shown for Clarity.  
 2. Where Pour-back is not protected by Traffic or Pedestrian/Bicycle Railing, Coat Pour-back with High Molecular Weight Methacrylate.

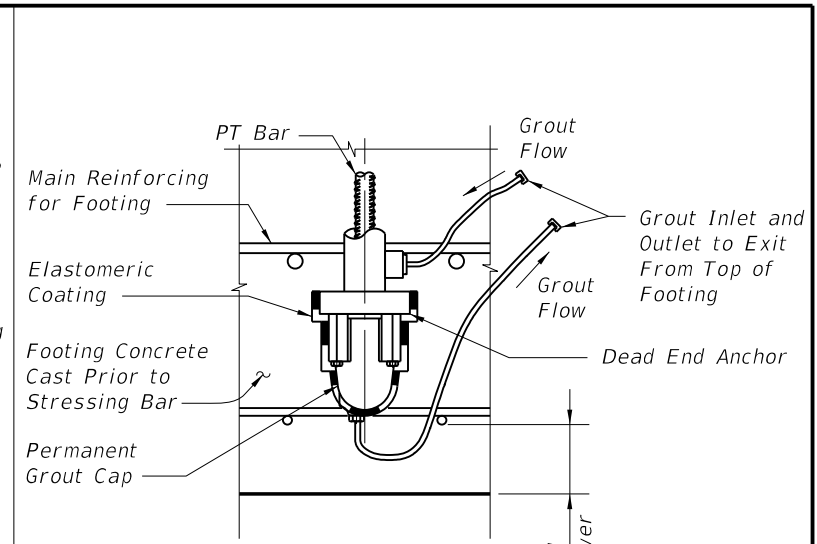

TYPE 8

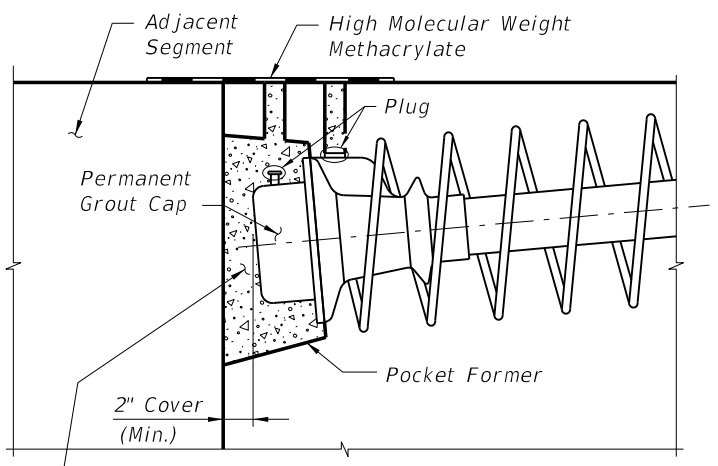

TYPE 3

Epoxy Grout Pour-back placed after permanent tendons anchored in adjacent segment have been stressed

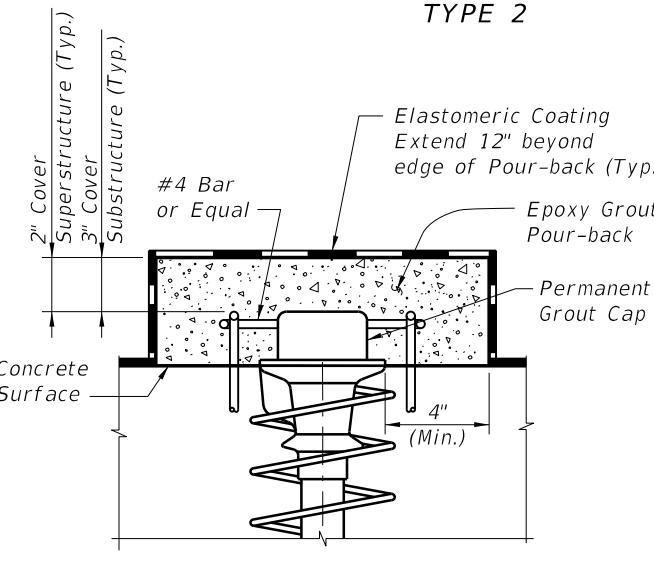

TYPE 4

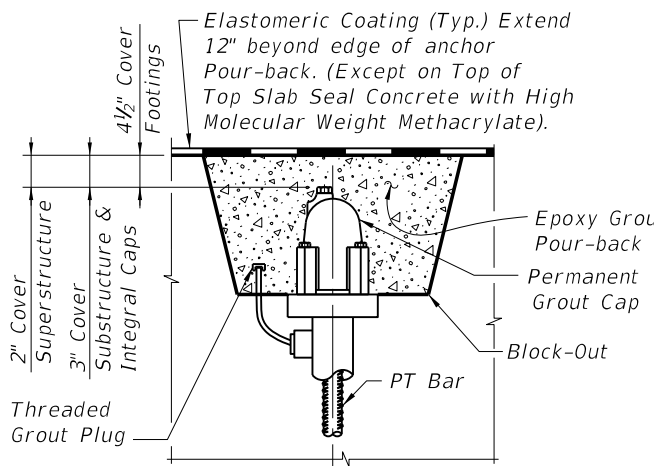

TYPE 9

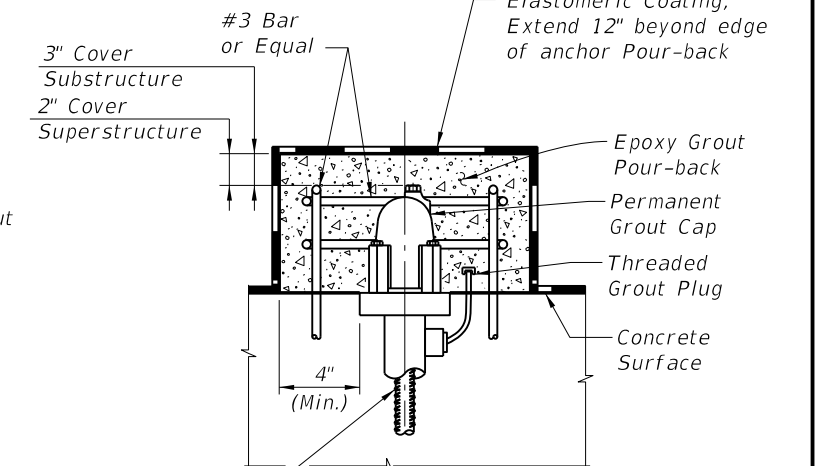

TYPE 10

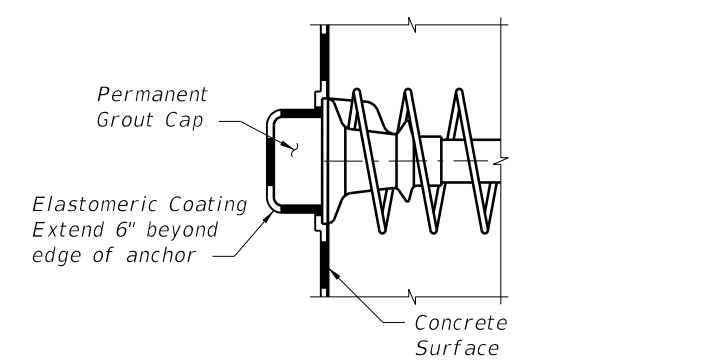

TYPE 5

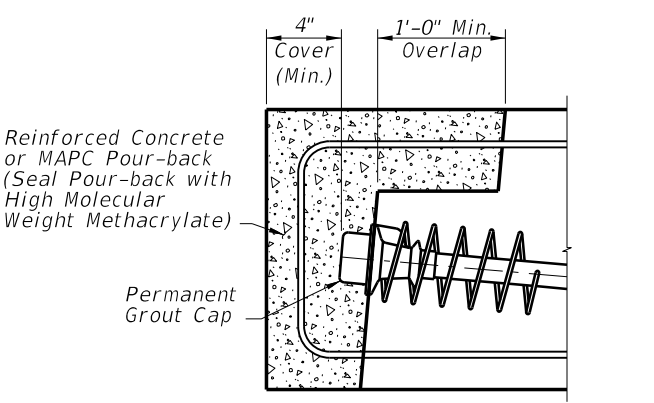

TYPE 6

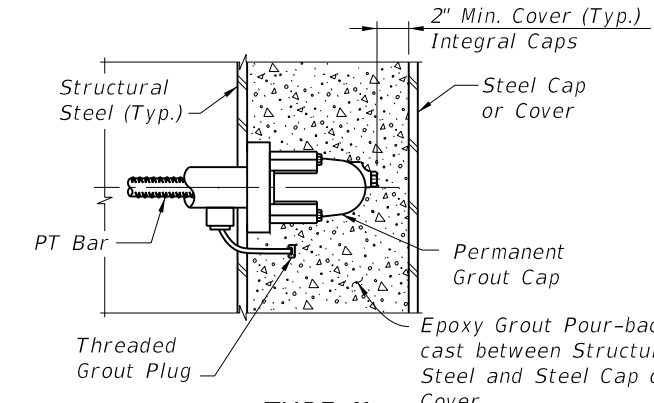

TYPE 11

(Shear Studs not Shown for Clarity)

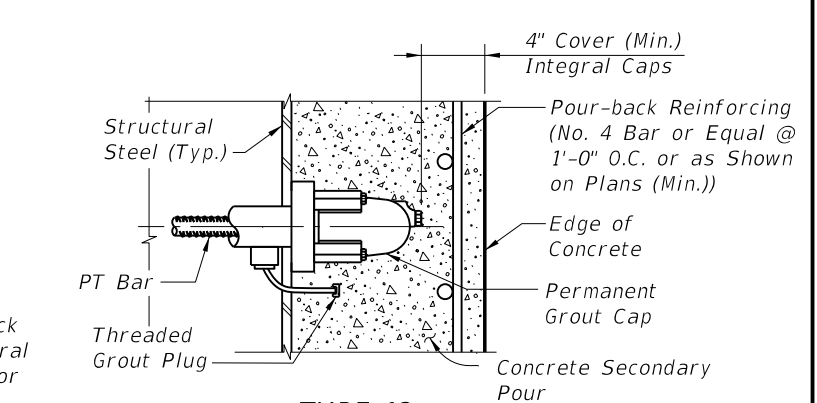

TYPE 12

(Shear Studs not Shown for Clarity)

ANCHOR PROTECTION FOR PT TENDONS

ANCHOR PROTECTION FOR PT BARS

6/24/2013 8:04:21 PM sm970re C:\projects\standards\structures\current\ready\4release\2014B00K\21802-1of1.dgn

LAST REVISION 01/01/12	REVISION	DESCRIPTION:	 <b>FDOT 2014 DESIGN STANDARDS</b>	<b>POST-TENSIONING ANCHORAGE PROTECTION</b>	INDEX NO. <b>21802</b>	SHEET NO. <b>1 of 1</b>
---------------------------	----------	--------------	--	---	---------------------------	----------------------------