

C:\projects\standards\structures\current\ready\4release\2014\BOK\20910-1 of 2.dgn sm970re 7:57:57 PM 6/24/2013

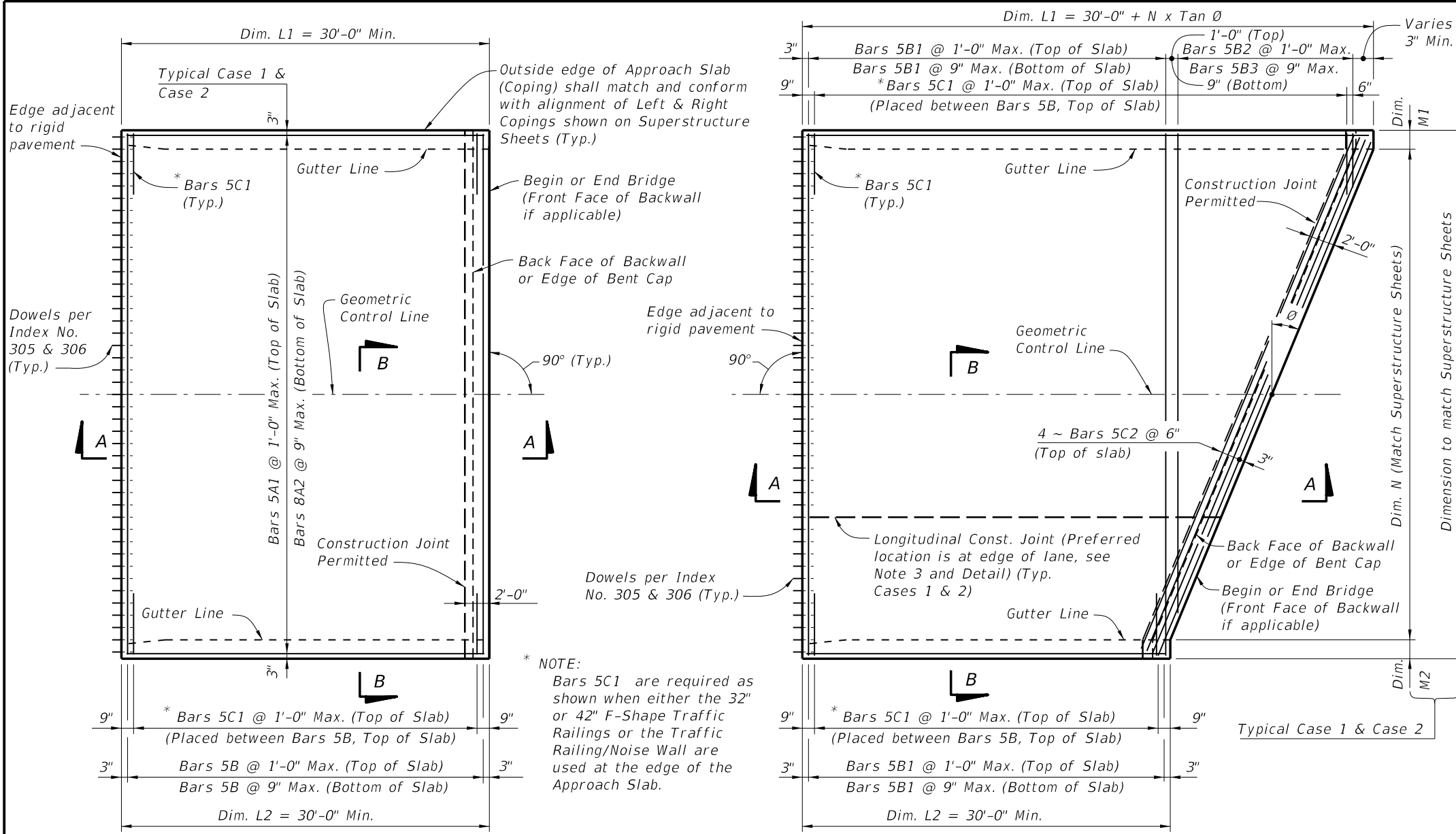

- ### GENERAL NOTES
- SURFACE TREATMENT:** Apply a Class 4 Floor Finish (Grooved) to the riding surface from begin or end approach slab joint to begin or end bridge. See Bid Item Notes. Apply a broomed finish to sidewalk areas.
  - UTILITIES:** If required, see Structures Plans, Utility Conduit Detail Sheet for details.
  - When a longitudinal construction joint is necessary or allowed by the Engineer, the transverse steel shall be extended as shown in the Longitudinal Construction Joint Detail.
  - The plan view for CASE 1 applies when the skew angle ( $\theta$ ) =  $0^\circ$ . Relevant details also apply to CASE 2.
  - The plan view for CASE 2 applies where the skew angle ( $\theta$ ) is  $> 0^\circ$ . The slab shown represents a skew to the right for an approach slab at begin bridge; approach slab at the end of bridge or a left skew shall be treated similarly. The shown reinforcement shall be utilized, and Dowels shall be provided in accordance with Index Nos. 305 and 306.
  - Railings, parapets and traffic separators shall be provided as shown in Structures Plans. Payment for these items shall be included in the pay item for the required item. Raised sidewalks shall be provided as shown in Structures Plans. Payment shall be included in the pay items for approach slab concrete and reinforcement. Welded Wire Reinforcement (WWR) for the edge of Approach Slabs on retaining wall is not included in the estimated quantity for reinforcing steel and is considered incidental to the work. WWR must consist of Deformed wire meeting the requirements of Specification Section 931.
  - PROFILOGRAPH:** If profilograph requirements apply, planing may be required. The permitted construction joint shown in Section A-A will facilitate the placement of the expansion joint.
  - Approach slabs shown in Plan View Cases 1 and 2 represent a typical approach slab with edge barriers and no sidewalks. See additional approach slab sheets for sidewalk and other pertinent details.

**CROSS REFERENCES:**

For Section B-B, Longitudinal Construction Joint Detail and Approach Slab Details see Index No. 20910, Sheet 2.

For Estimated Quantities see Structures Plans.

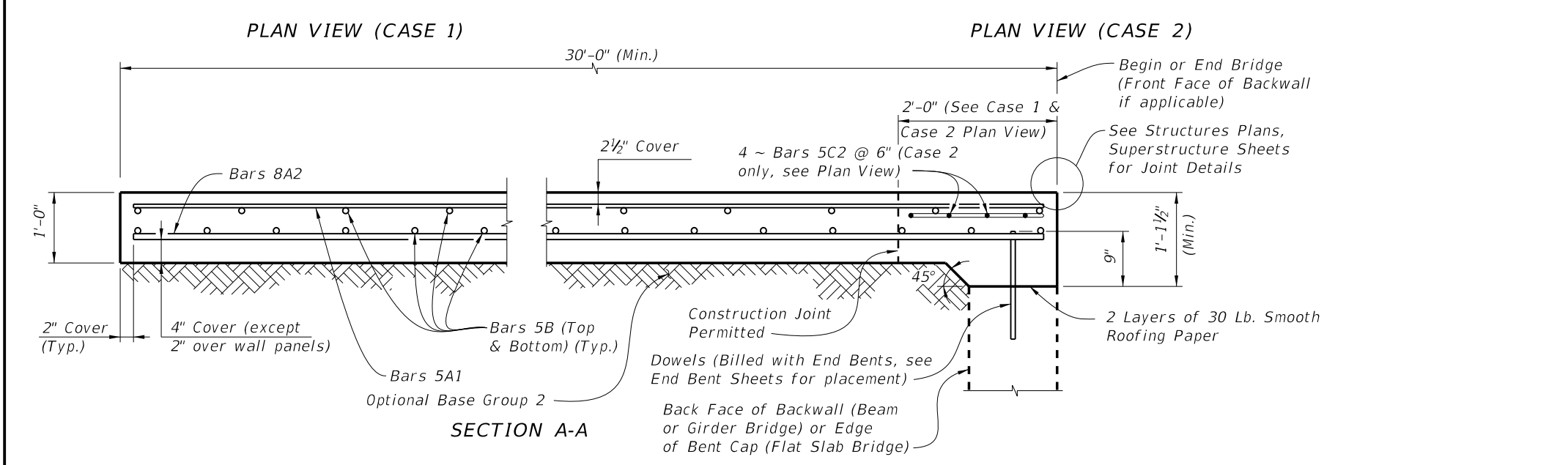

LAST REVISION 07/01/13	REVISION	DESCRIPTION:	 <b>FDOT 2014</b> <b>DESIGN STANDARDS</b>	<b>APPROACH SLABS</b> <b>(RIGID PAVEMENT APPROACHES)</b>	INDEX NO. <b>20910</b>	SHEET NO. <b>1 of 2</b>
---------------------------	----------	--------------	---	---	---------------------------	----------------------------

C:\projects\standards\structures\current\ready\4release\_2014\BOOK\_20910-2of2.dgn  
smg70re  
7:57:59 PM  
6/24/2013

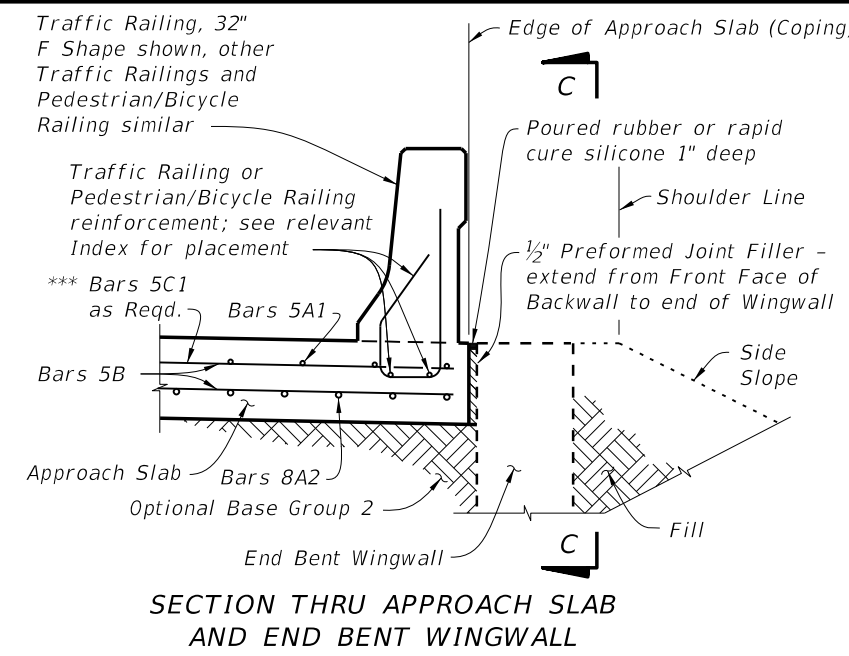
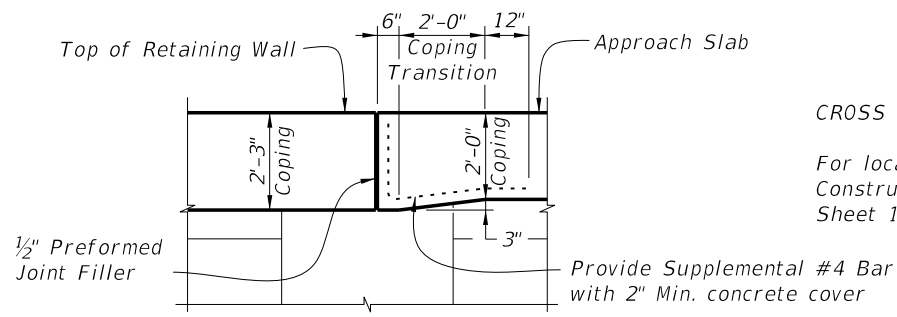
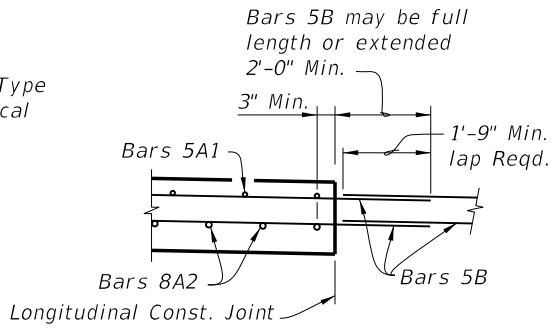
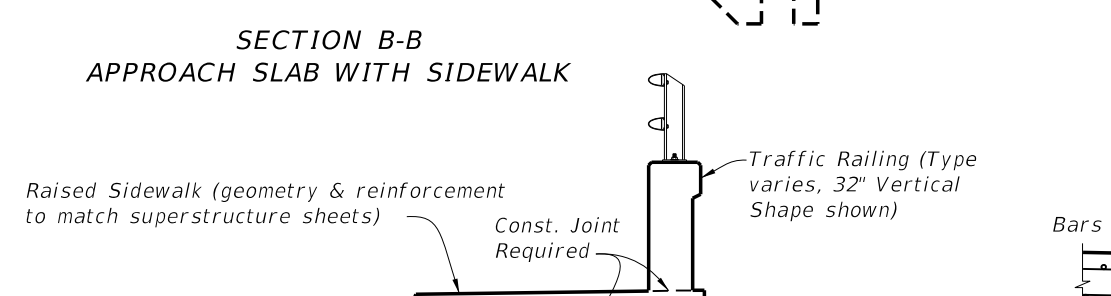
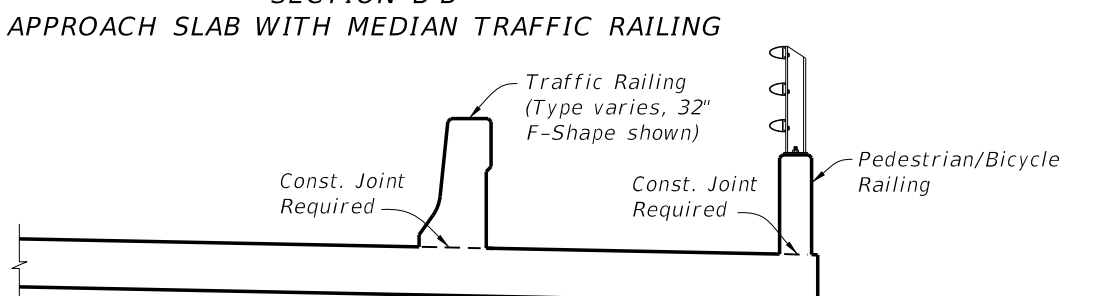
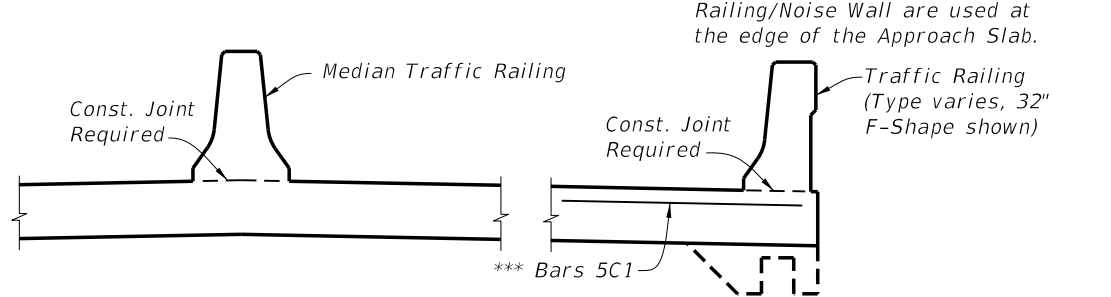
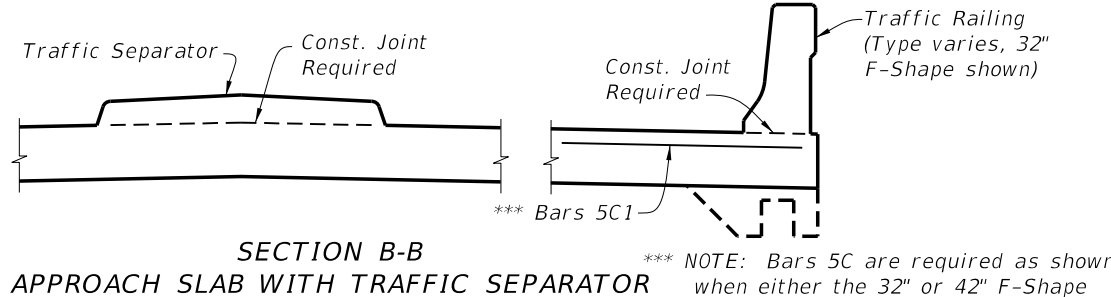
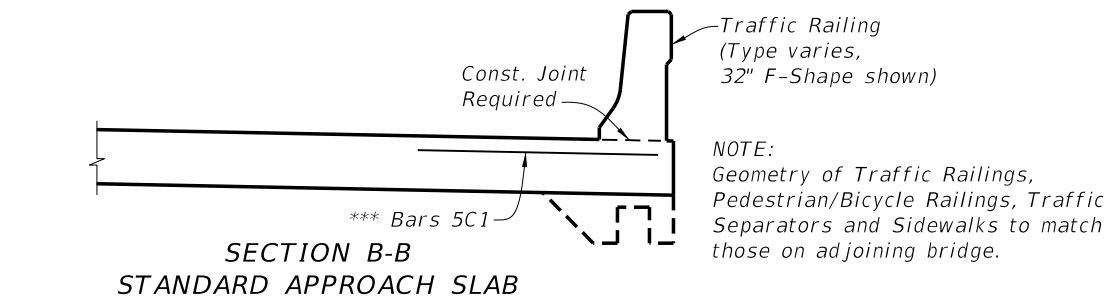

**SECTION THRU APPROACH SLAB AND END BENT WINGWALL**

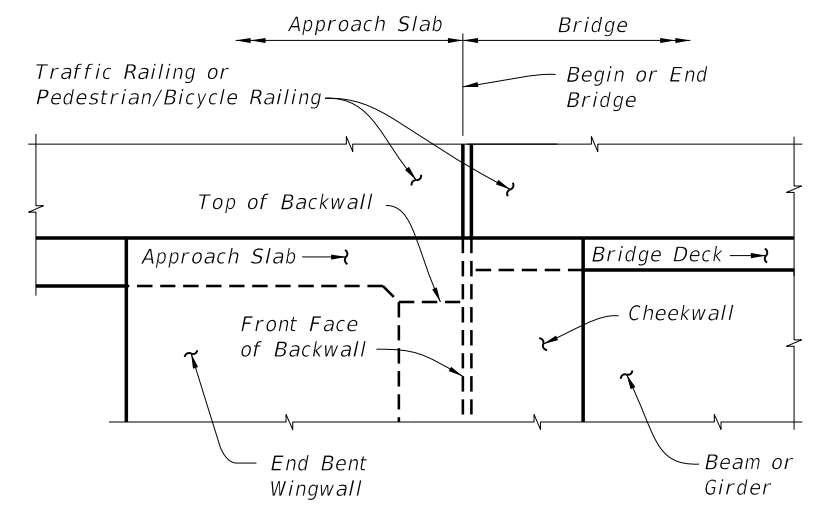

**VIEW C-C AT BEGIN OR END BRIDGE (BEAM BRIDGE SHOWN, FLAT SLAB BRIDGE SIMILAR)**

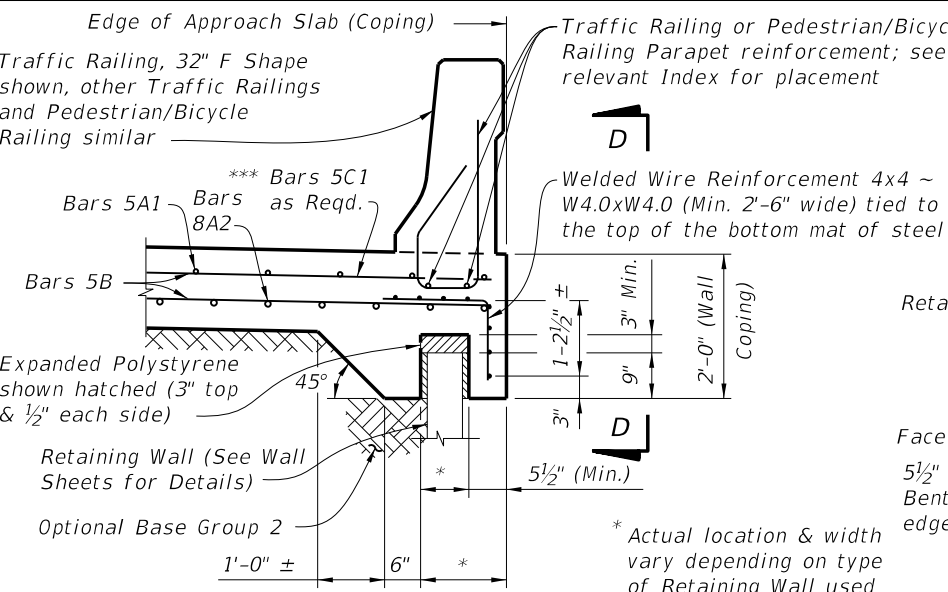

**SECTION THRU APPROACH SLAB AND RETAINING WALL**

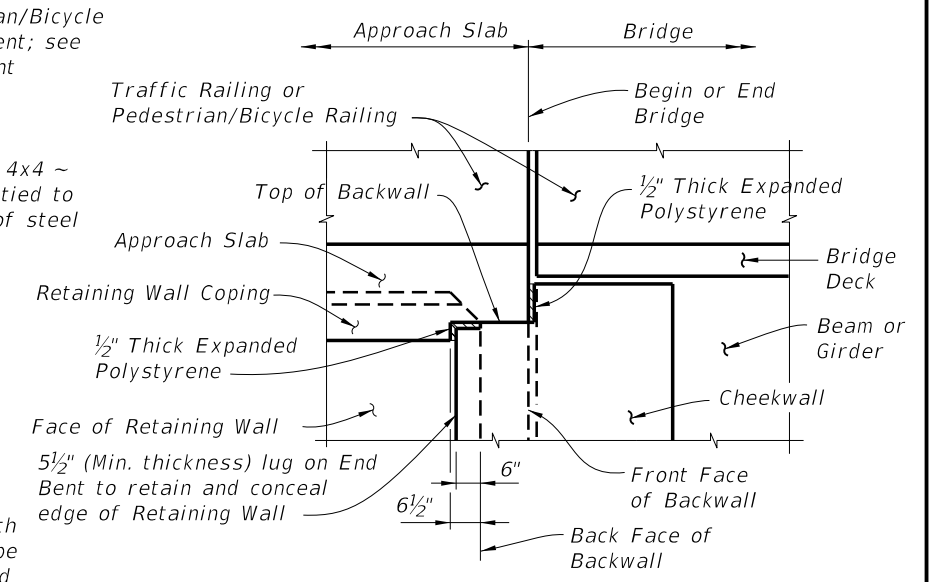

**VIEW D-D AT BEGIN OR END BRIDGE (BEAM BRIDGE SHOWN, FLAT SLAB BRIDGE SIMILAR)**

**CROSS REFERENCES:**  
For location of Section B-B and Longitudinal Construction Joint Detail see Index No. 20910, Sheet 1.

LAST REVISION 07/01/13	REVISION	DESCRIPTION:	 <b>FDOT 2014 DESIGN STANDARDS</b>	<b>APPROACH SLABS (RIGID PAVEMENT APPROACHES)</b>	INDEX NO. <b>20910</b>	SHEET NO. <b>2 of 2</b>
---------------------------	----------	--------------	---	---	---------------------------	----------------------------