

*The 45" Ø Void in the pile shall be positively vented to water or air after the final pile installation. If the 3 1/2" Ø vents are included in the pile cut-off section, then venting shall be provided by the use of a 1" Ø PVC conduit through the substructure cap or column.

ELEVATION

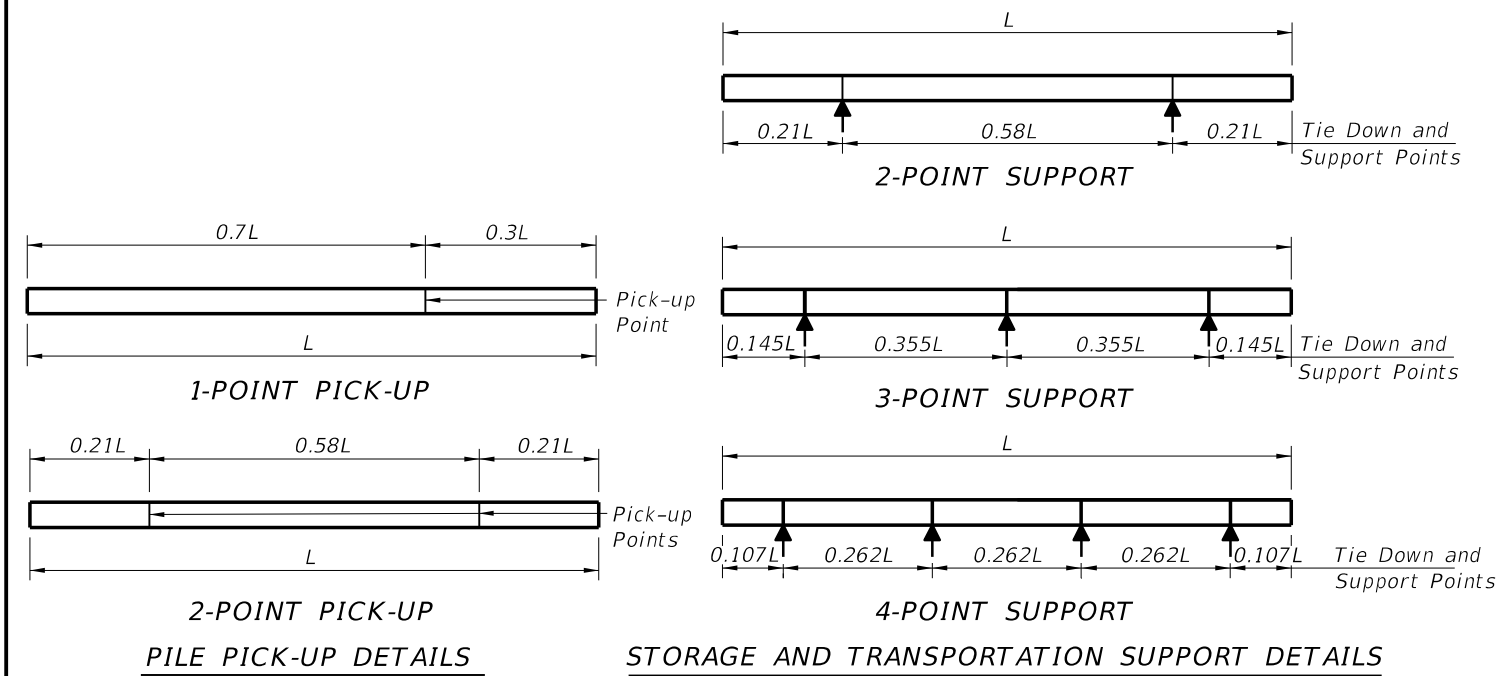

PILE PICK-UP DETAILS

STORAGE AND TRANSPORTATION SUPPORT DETAILS

TABLE OF MAXIMUM PILE PICK-UP AND SUPPORT LENGTHS		
Maximum Pile Length (Feet)	Required Storage and Transportation Detail	Pick-Up Detail
122	2, 3, or 4 point	1 Point
174	2, 3, or 4 point	2 Point

NOTES

DESIGN SPECIFICATIONS:
 Florida Department of Transportation (FDOT) "Structures Design Guidelines", Current Edition.
 American Association of State Highway and Transportation Officials (AASHTO) "LRFD Bridge Design Specifications", Current Edition.

SPIRAL TIES:
 One full wrap of spirals is required at both the head and tip of pile. One half turn required for spiral splices.

CONCRETE CLASS:
 Concrete for all piles shall be Class V (Special). Concrete for pile splices shall be Class IV. See "GENERAL NOTES" in Structures Plans for any specific locations where the use of Silica Fume is required.

CONCRETE STRENGTH:
 The cylinder strength shall be 4,000 psi minimum at time of transfer of the Prestressing Force.

SPLICE BONDING MATERIAL:
 The material to form the joint between pile sections shall be a Type B Epoxy Compound in accordance with Specification Section 926. The bonding agent used on internal pile surfaces shall be a Type A Epoxy Compound in accordance with Specification Section 926. Epoxy Compounds used shall be contained on the Qualified Products List (QPL). Use Epoxy Bonding Compound or Epoxy Mortar as recommended by the Manufacturer. For Epoxy Mortar only use sand or other filler material supplied by the manufacturer and in the proportions recommended.

PICK-UP POINTS:
 Piles shall be marked at the pick-up points to indicate proper points for attaching handling lines.

REINFORCING STEEL:
 All reinforcing steel shall be Grade 60, except that smooth steel wire (W11 spiral ties and W20 ties) shall be manufactured from cold drawn steel wire meeting the requirements of ASTM A82.

PRESTRESSING STEEL:
 Prestressing steel shall be 0.6" Ø seven-wire strand, Grade 270 low relaxation, at 44.0 kips.

PILE DRIVING AFTER SPLICING:
 Pile splices shall reach a minimum strength of 5500 psi before driving is resumed.

C:\projects\standards\structures\current\ready\release\2014\BOOK\20660-1 of 2.dgn sm970re 6/24/2013 7:57:22 PM

6/24/2013 7:57:24 PM sm970re C:\projects\standards\structures\current\ready\4release\2014B00K\20660-2of2.dgn

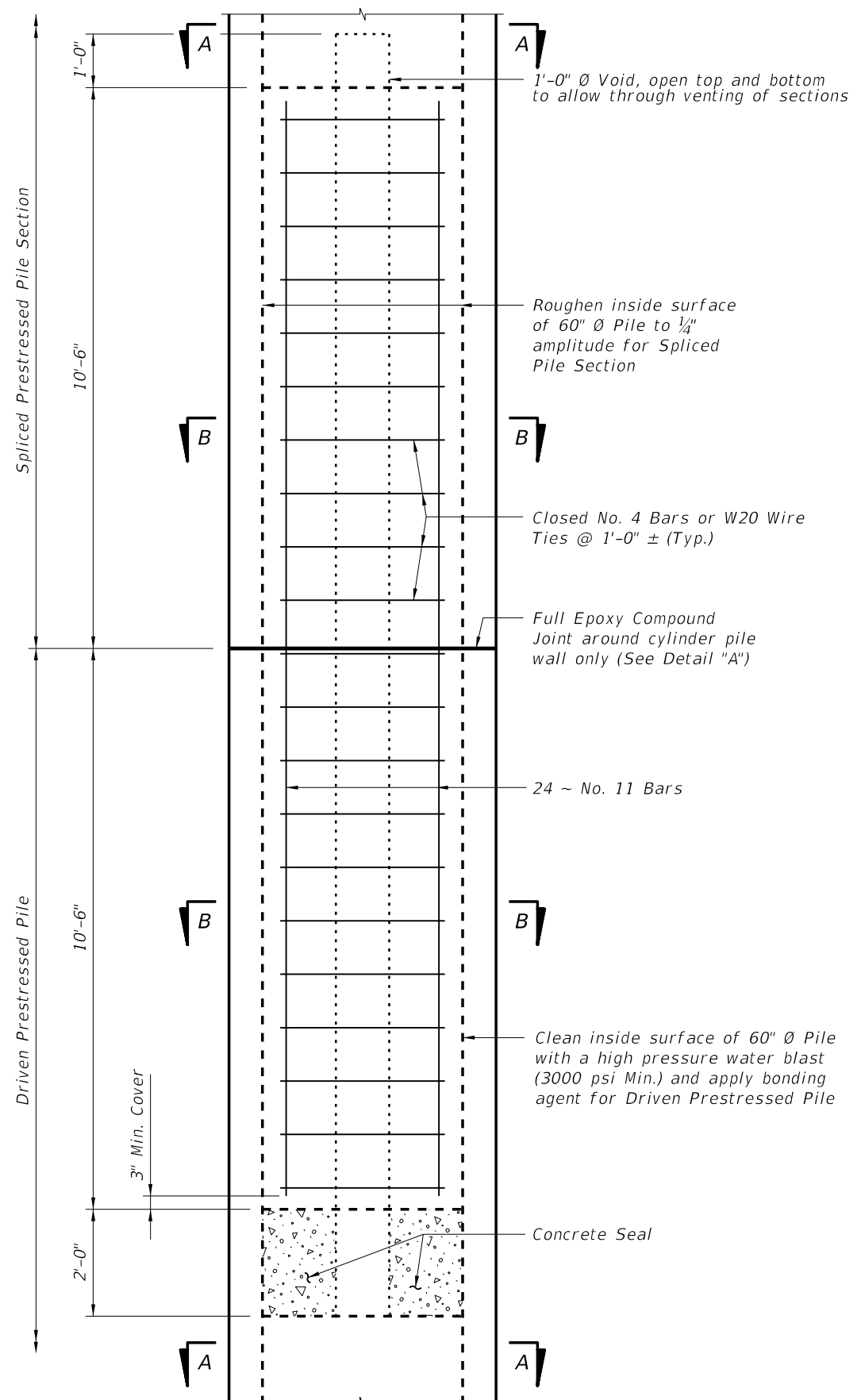

DRIVABLE UNFORESEEN FIELD SPLICE DETAIL
(Cast in Place Plug)

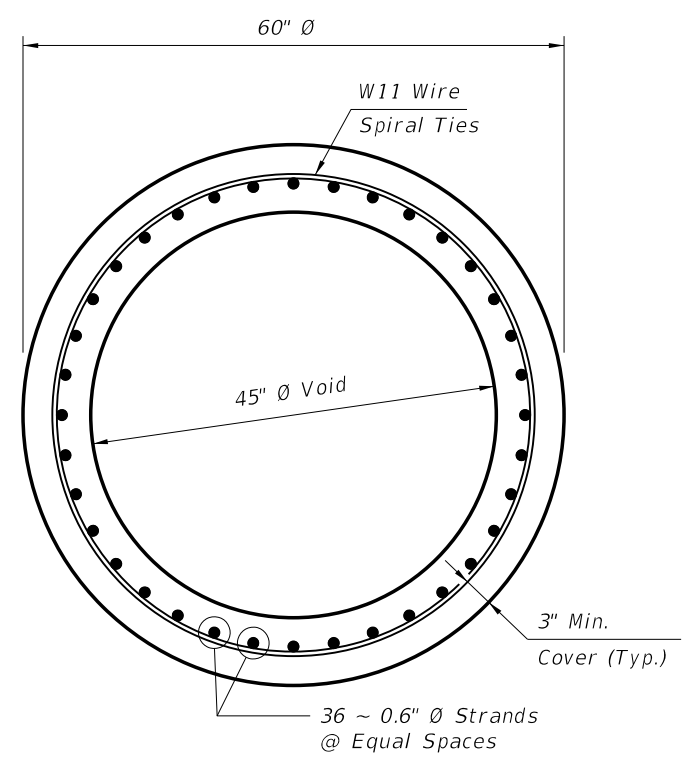

SECTION A-A

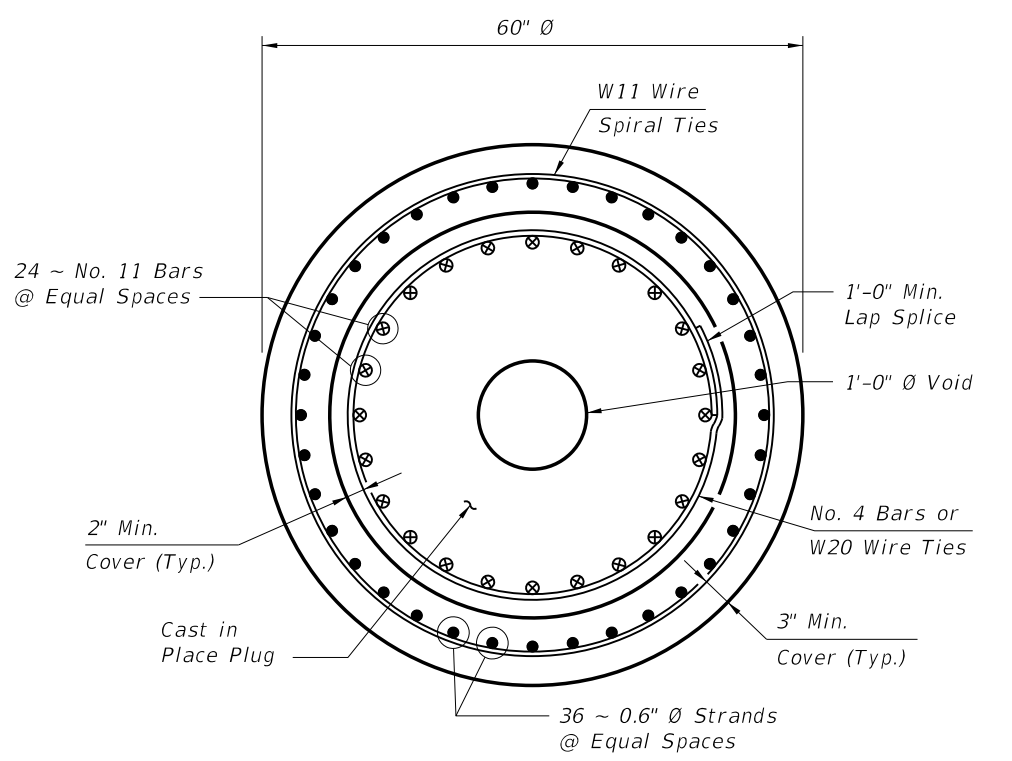

SECTION B-B

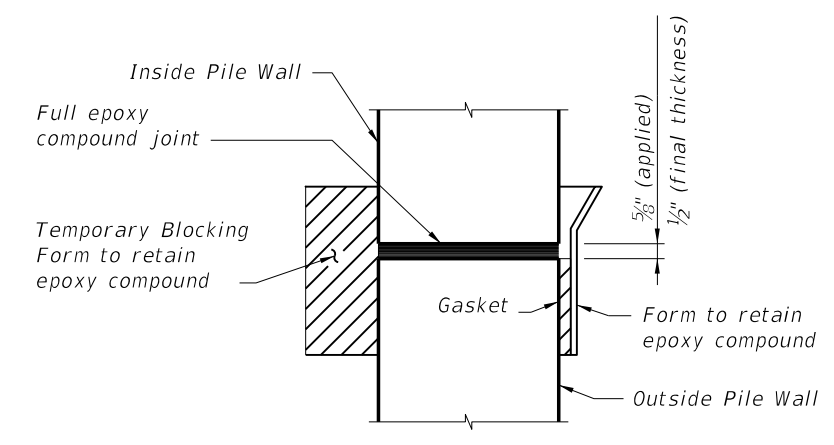

DETAIL "A"

LAST REVISION	REVISION	DESCRIPTION:	 <p>FDOT 2014 DESIGN STANDARDS</p>	<p>60" PRESTRESSED CONCRETE CYLINDER PILE</p>	<p>INDEX NO. 20660</p>	<p>SHEET NO. 2 of 2</p>
01/01/12						