

C:\projects\standards\structures\current\ready\4release\2014\BOOK\20078-1of2.dgn
sm970re
7:44:21 PM
6/24/2013

**CONVENTIONAL REINFORCING
BAR BENDING DETAILS**

BILL OF REINFORCING STEEL

MARK	NOTE NUMBERS	SIZE	NUMBER REQUIRED	LENGTH (NOTE 1)
A	—	6	8	28'-0"
C1	9, 10 & 11	3	20 (End 1)	Varies
C2	9, 10 & 11	3	20 (End 2)	Varies
D1	9, 10, 11 & 14	3	40 (End 1)	Varies
D2	9, 10, 11 & 14	3	40 (End 2)	Varies
D3	9 & 14	3	See Table	4'-3"
K	2, 9, 11 & 13	5	See Table	7'-8"
M1	9 & 10	4	18 (End 1)	Varies
M2	9 & 10	4	18 (End 2)	Varies
M3	9	4	See Table	3'-8"
N	3 & 4	$\frac{3}{8}$ " \emptyset Strand	4	Dim. L
Y	9 & 11	5	16	6'-0"
Z	2, 9, 11 & 13	5	12	7'-2"

BENDING DIAGRAMS (See Note 1)

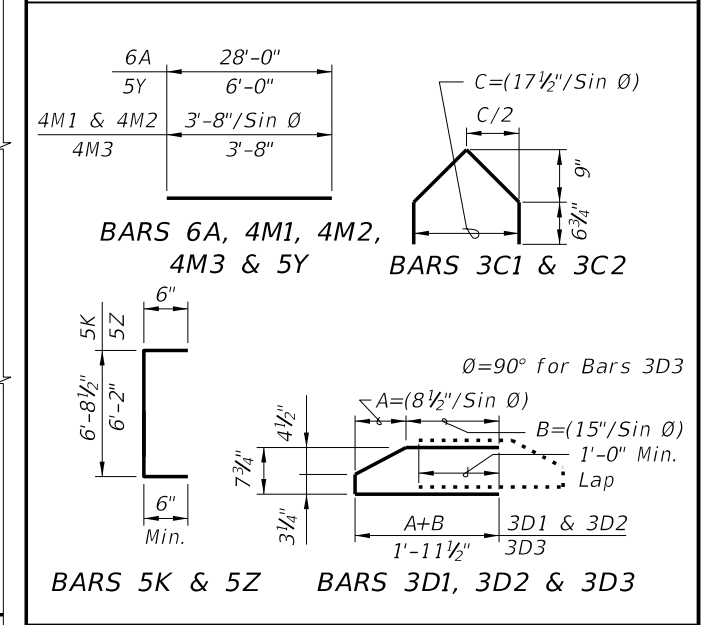

NOTES:
 A. Work this Index with Index No. 20010 - Typical Florida-I Beam Details and Notes and the Florida-I Beam - Table of Beam Variables in Structures Plans.
 B. For referenced notes, see Index No. 20010.
 C. For Dimensions A, B, C, D, L, R & V1 and number of spaces S1 thru S4, see Florida-I Beam - Table of Beam Variables in Structures Plans.

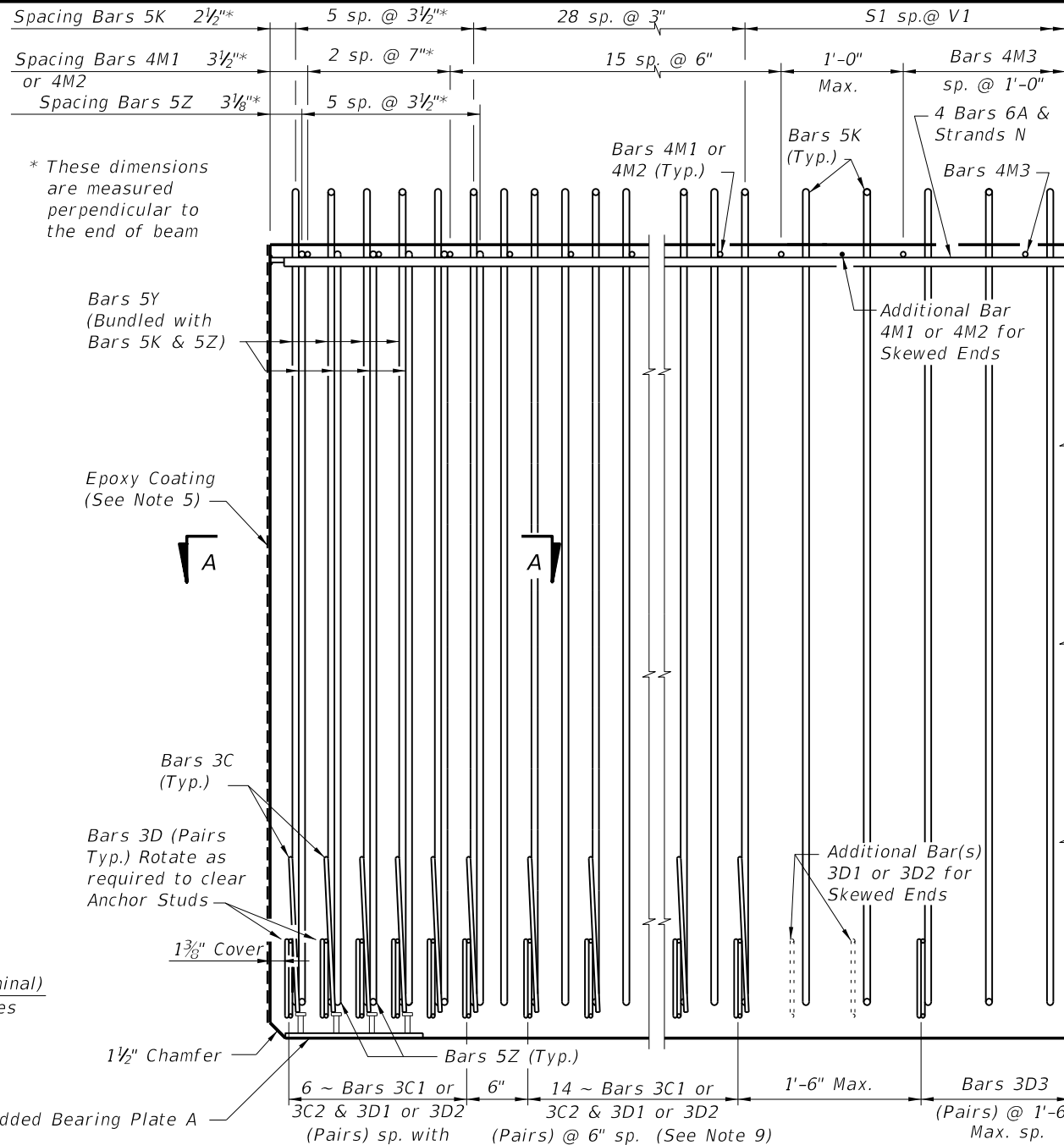

**ELEVATION AT END OF BEAM
(Flanges Not Shown For Clarity)
(End 1 Shown, End 2 Similar)**

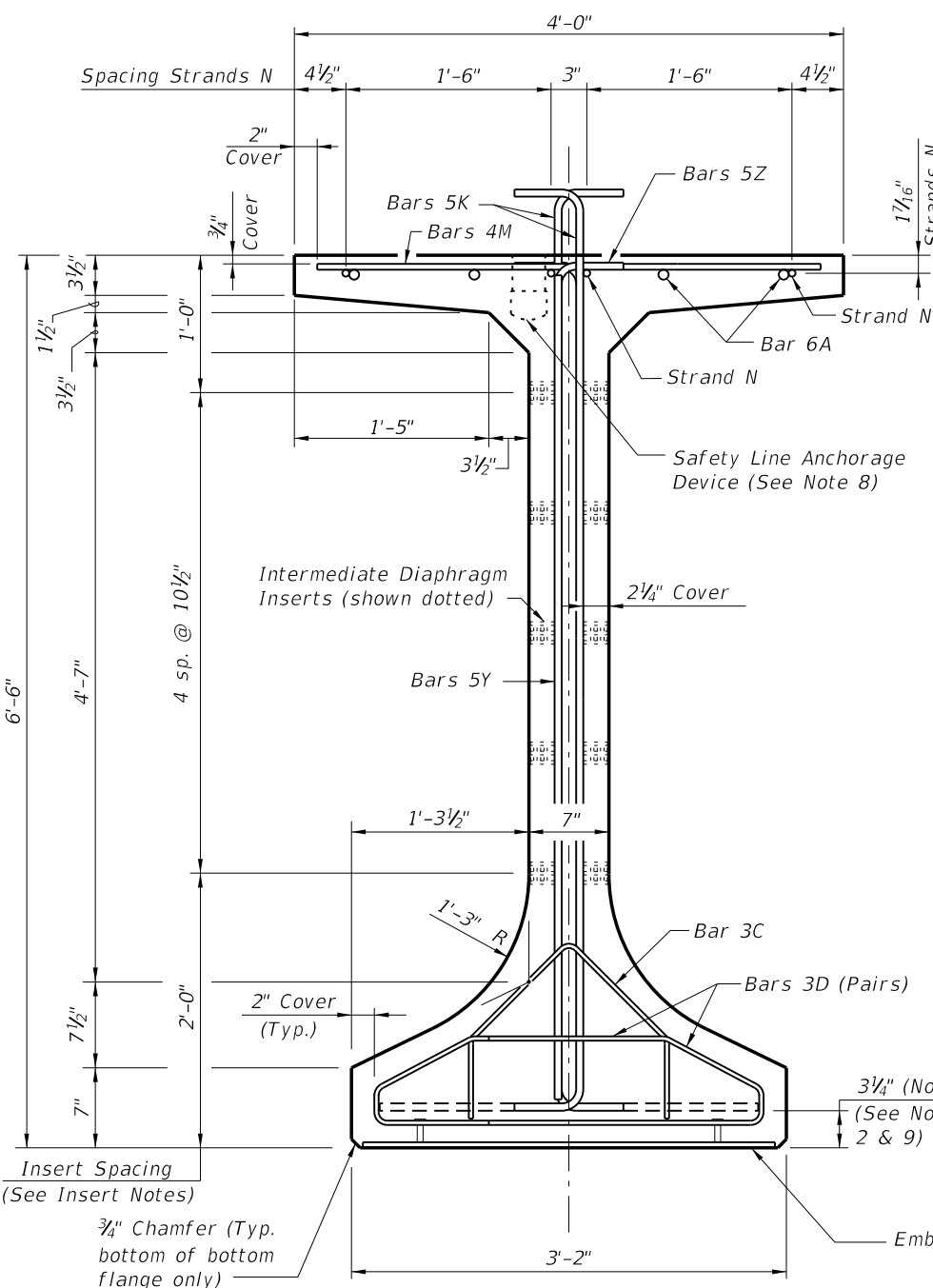

END VIEW

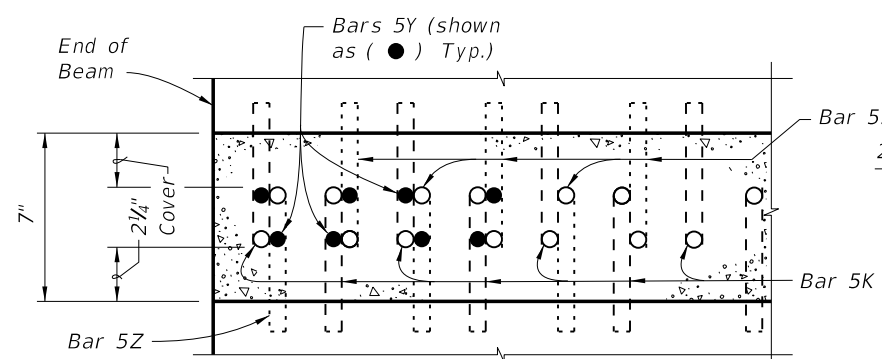

**SECTION A-A FOR CONVENTIONAL REINFORCING
(Showing Bars 5K, 5Y & 5Z Only)**

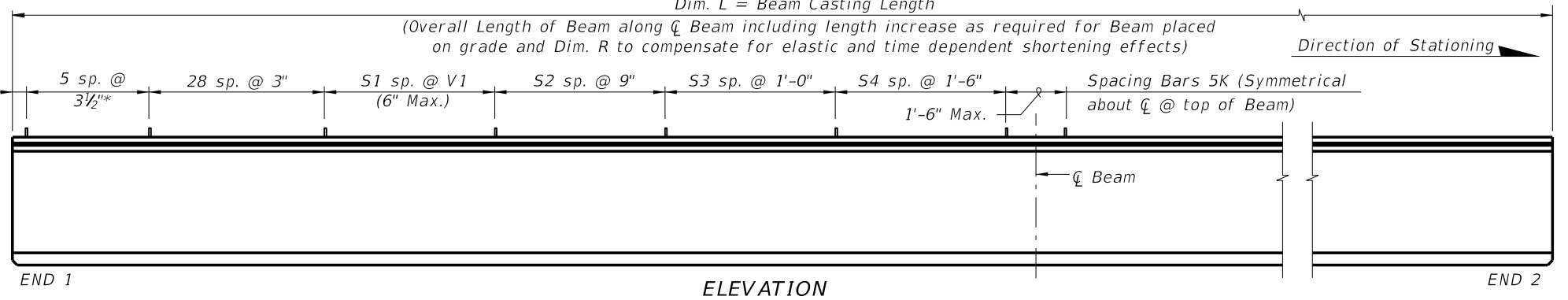

ELEVATION

ALTERNATE REINFORCING STEEL (WELDED WIRE REINFORCEMENT) DETAILS

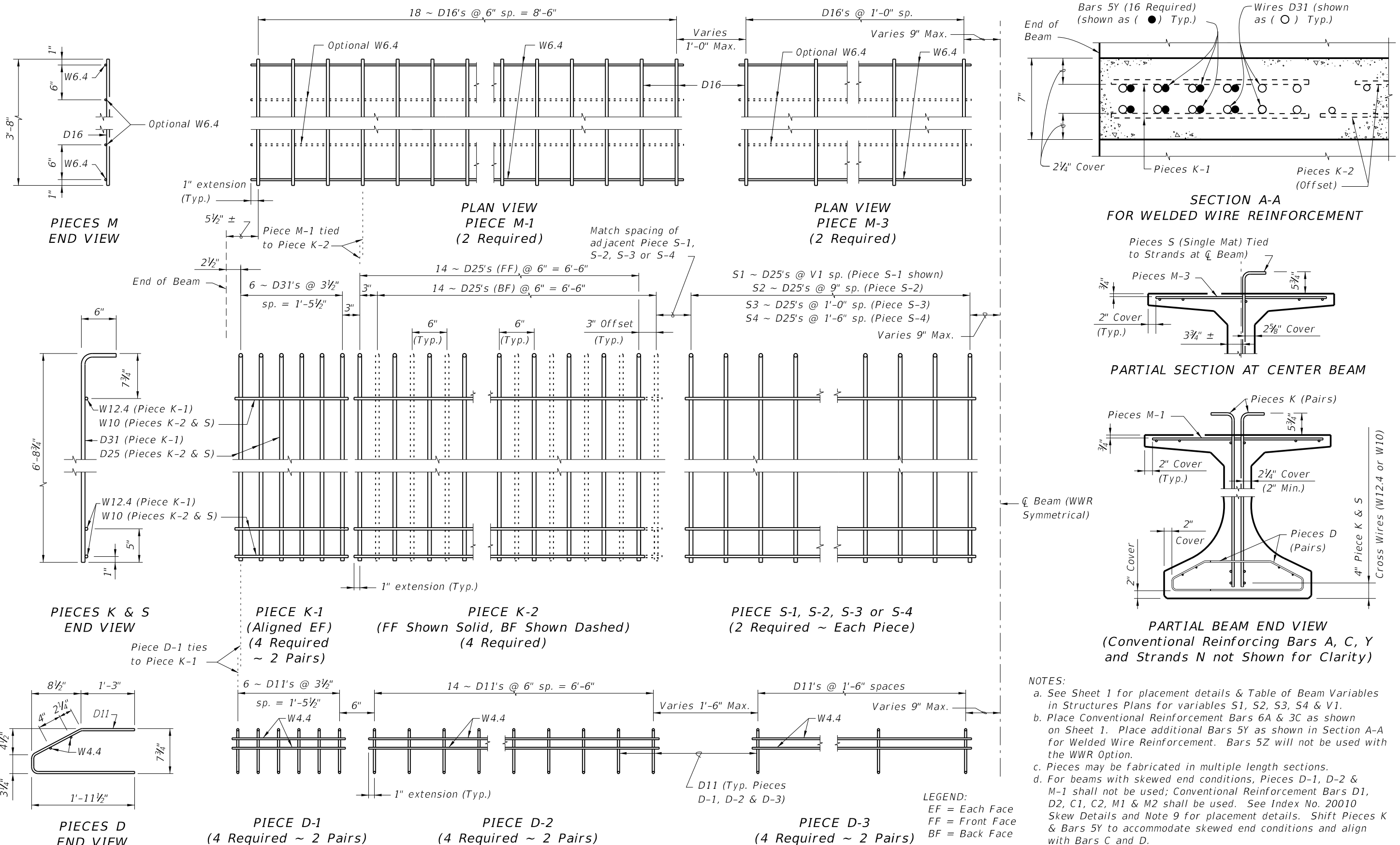

- NOTES:**
- See Sheet 1 for placement details & Table of Beam Variables in Structures Plans for variables S1, S2, S3, S4 & V1.
 - Place Conventional Reinforcement Bars 6A & 3C as shown on Sheet 1. Place additional Bars 5Y as shown in Section A-A for Welded Wire Reinforcement. Bars 5Z will not be used with the WWR Option.
 - Pieces may be fabricated in multiple length sections.
 - For beams with skewed end conditions, Pieces D-1, D-2 & M-1 shall not be used; Conventional Reinforcement Bars D1, D2, C1, C2, M1 & M2 shall be used. See Index No. 20010 Skew Details and Note 9 for placement details. Shift Pieces K & Bars 5Y to accommodate skewed end conditions and align with Bars C and D.

C:\projects\standards\structures\current\ready\4release\2014\B00K\20078-2of2.dgn smg70re 7:44:23 PM 6/24/2013

LAST REVISION 07/01/10	DESCRIPTION:	 <p>FDOT 2014 DESIGN STANDARDS</p>	<p>FLORIDA-I 78 BEAM - STANDARD DETAILS</p>	<p>INDEX NO. 20078</p>	<p>SHEET NO. 2 of 2</p>
---------------------------	--------------	---	---	----------------------------	-----------------------------