

C:\projects\standards\18110-01.dgn
 sm970re
 7:36:56 PM
 6/24/2013

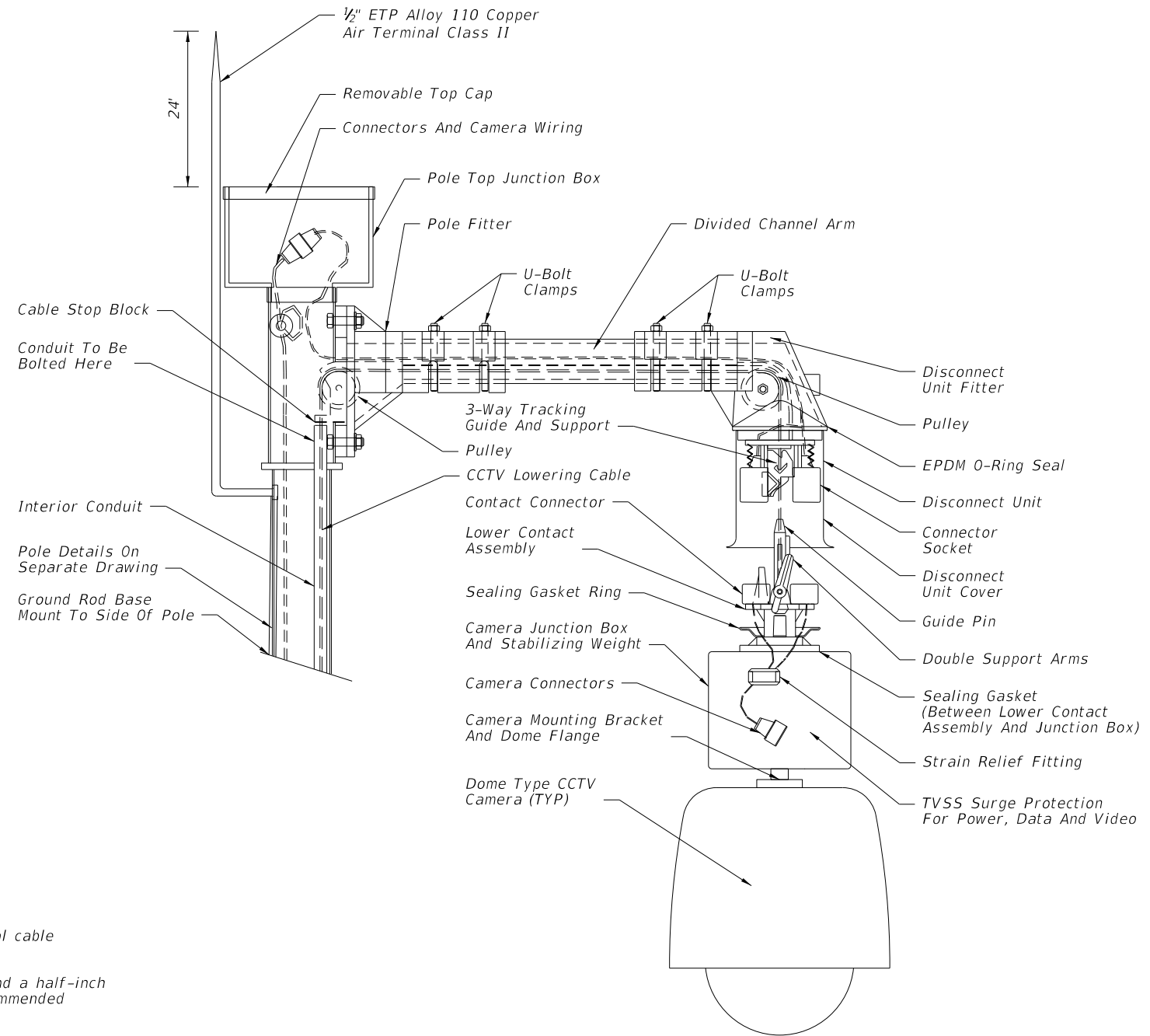

CAMERA LOWERING DEVICE DETAIL

CAMERA MOUNTING WITH LOWERING DEVICE

GENERAL NOTES:

1. Lowering device to be shipped ready for pole attachment to include 100 ft. of composite power and signal cable prewired to lowering device at the factory.
2. The lowering device manufacturer shall supply both a portable lowering tool with a manual hand crank and a half-inch chuck variable-speed reversible industrial-duty electric drill that matches the winch's manufacturer-recommended revolutions per minute. One lowering tool per every 10 lowering devices is required.
3. The lowering device manufacturer shall provide an on-site installation inspection and operator instruction and certification. This ensures the product is assembled correctly and that all necessary persons are trained in the proper, safe operation of the system. Before erecting the first pole the contractor must contact the lowering device supplier and schedule a manufacturer's representative to be on-site.
4. Design camera mounting arm and connection to tenon according to FDOT Structures Manual (current edition).
5. Camera to be mounted to camera junction box and stabilizing weight via 1 1/2" Standard NPT Pipe Thread.
6. Use air terminal extension when the pole top junction box is wider than top of pole.
7. The stainless steel device lowering cable shall be installed inside the pole within a 1 1/4" diameter PVC conduit.
8. All communication and power cables must be neatly bundled and secured.
9. Use a Camera Lowering Device listed on the Approved Product List (APL).
10. See Index 18113 for concrete pole details and Index 18111 for steel pole details.

LAST REVISION	01/01/10
---------------	----------

DESCRIPTION:	
--------------	--



CAMERA MOUNTING DETAILS	
-------------------------	--

INDEX NO.	18110
-----------	-------

SHEET NO.	1 of 2
-----------	--------

C:\projects\standards\18110-02.dgn
smg70re
7:36:58 PM
6/24/2013

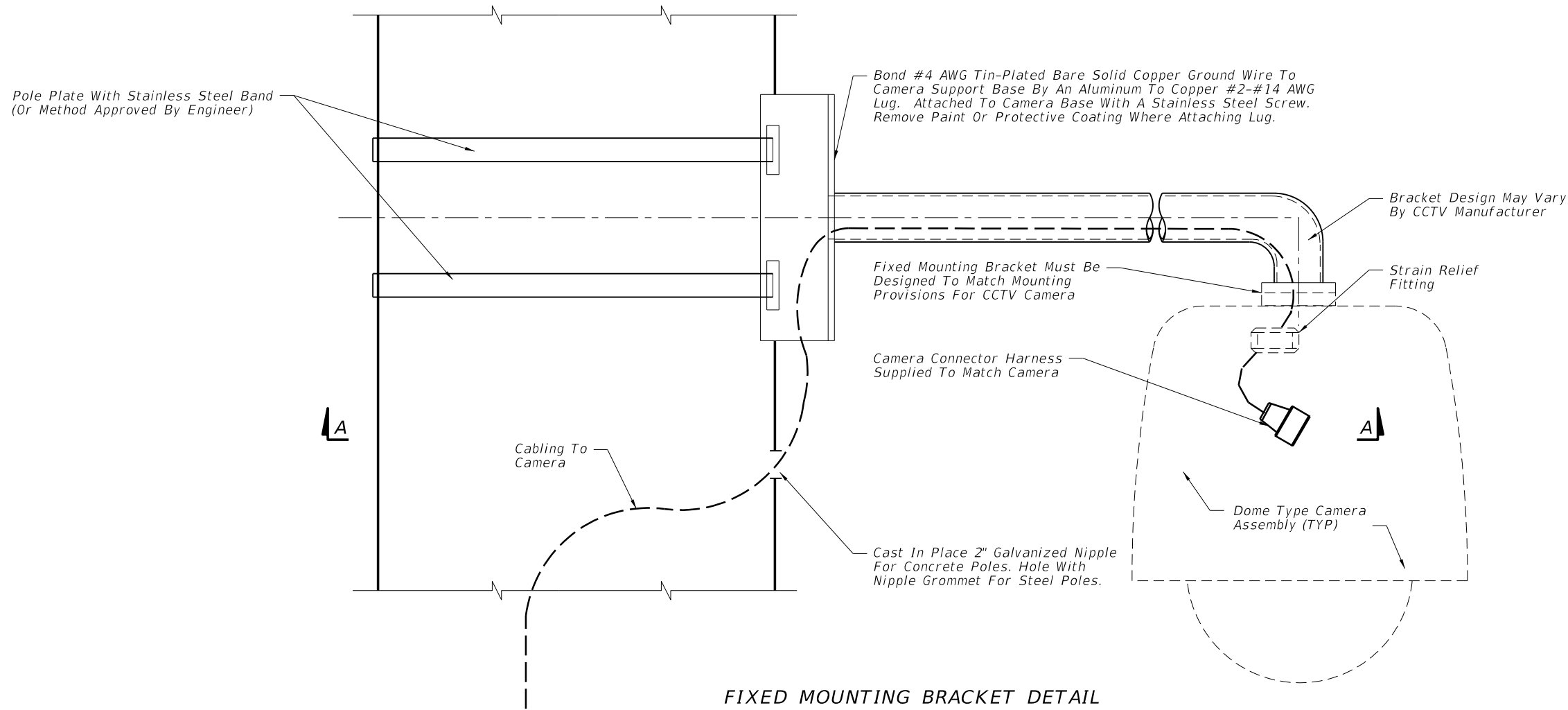

FIXED MOUNTING BRACKET DETAIL
Not To Scale

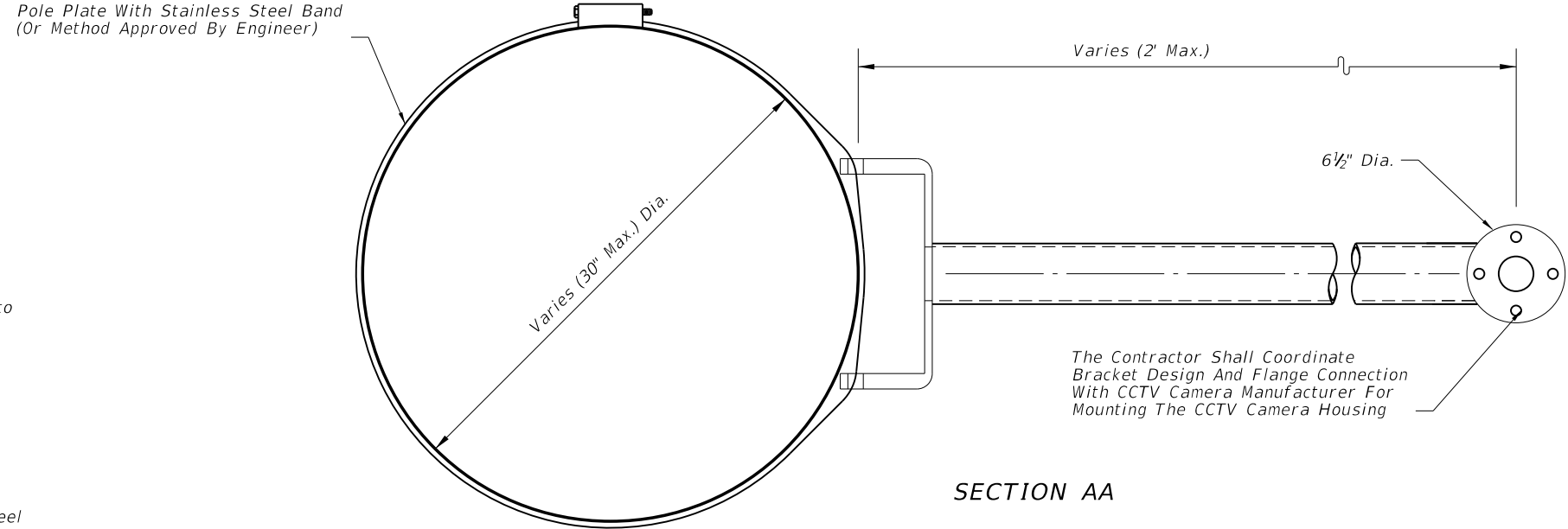

SECTION AA

CAMERA MOUNTING WITH FIXED BRACKET

GENERAL NOTES:

1. Verify the pole type, the dimensions of the pole at the point of installation of the camera mount, and angle with respect to the roadway before manufacturing camera mount assembly.
2. Design camera mounting arm and connection to the pole according to FDOT Structures Manual (current edition).
3. No field welding shall be permitted.
4. Mounting bracket arm shall be level after installation.
5. The contractor shall submit shop drawings for the proposed fixed mounting arm, signed and sealed by a Professional Engineer registered in the State of Florida, to the Engineer for review and approval.
6. See Index 18113 for concrete pole details and Index 18111 for steel pole details.
7. Galvanized pipe connections and conduit entry points shall be sealed in accordance with Section 630 of the Standard Specifications.

LAST REVISION	01/01/10	DESCRIPTION:	 <p>FDOT 2014 DESIGN STANDARDS</p>	<p>CAMERA MOUNTING DETAILS</p>	<p>INDEX NO. 18110</p>	<p>SHEET NO. 2 of 2</p>
---------------	----------	--------------	--	---------------------------------------	-----------------------------------	------------------------------------