

C:\projects\standards\roadway\13000-s\13417-01.dgn  
 sm970re  
 7:10:37 PM  
 6/24/2013

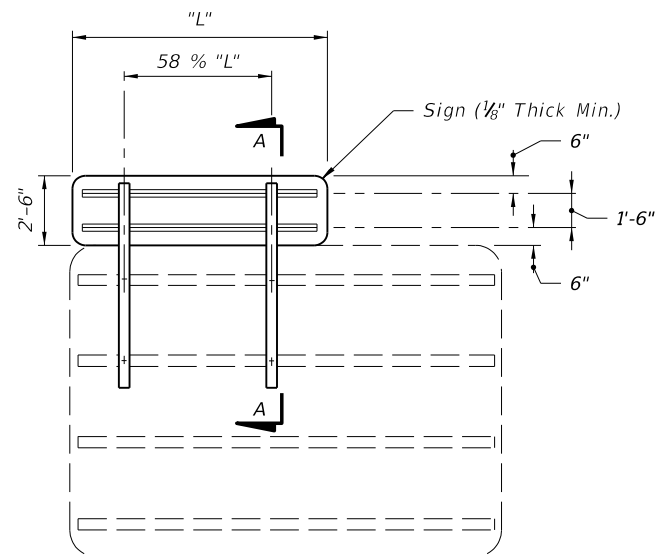

NOTE: Exit numbering panel shall be located to the right side for right exit and to the left for left exit.

Mounting of Exit Numbering Panels To Highway Signs

ELEVATION

Bolt Sign to Zee Using 1/4" Ø Aluminum Flat Head Bolts, Nuts and Lock Washers (Typ.) 12" Max Spacing

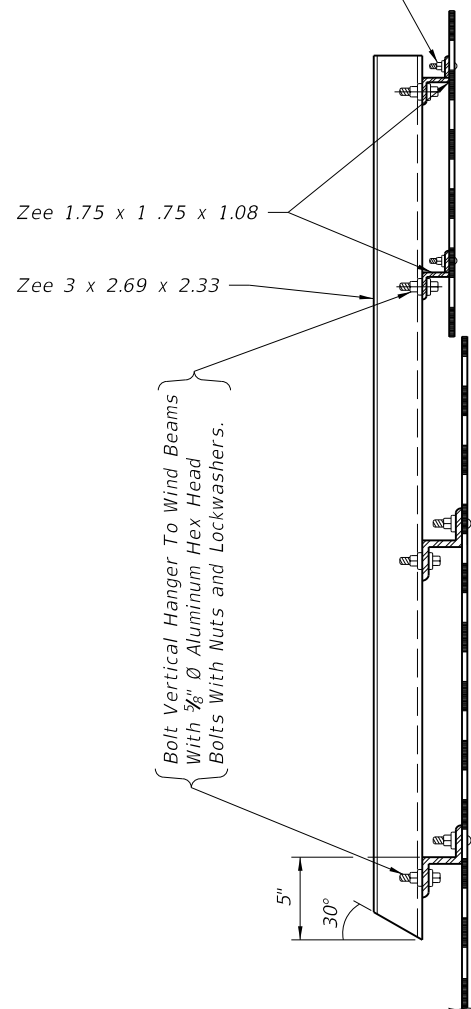

SECTION AA

GENERAL NOTES

DESIGN SPECIFICATION:  
 Design according to FDOT Structures Manual (current edition) Standard Specifications for Structural Supports for Highway Signs, Luminaires and Traffic Signals, AASHTO 2001.

SHEETS AND PLATES:  
 Material used shall meet the requirements of Aluminum Association Alloy 6061-T6 and ASTM B209.

MATERIALS:  
 All aluminum materials shall meet the requirements of the Aluminum Association Alloy 6061-T6 and also the following ASTM specifications for the following: Sheets and plates B209; extruded shapes B221 and standard structural shapes B308.

ALUMINUM BOLTS, NUTS & LOCK WASHERS:  
 Aluminum bolts shall meet the requirements of the Aluminum Association Alloy 2024-T4 (ASTM F468). The bolts shall have an anodic coating of at least .0002" thick and be chromate sealed. Lockwashers shall meet the requirement of Aluminum Association Alloy 7075-T6 (ASTM B221). Nuts shall meet the requirement of Aluminum Association Alloy 6262-T9 (ASTM F467) or 6061-T6.

SIGN FACE:  
 All sign face corners shall be rounded. See sign layout sheet for dimension "L" and sign face details. For mounting details refer to Index No. 11300.

LAST REVISION	REVISION	DESCRIPTION:	 <b>FDOT 2014</b> <b>DESIGN STANDARDS</b>	<b>MOUNTING EXIT NUMBER PANELS</b> <b>TO HIGHWAY SIGNS</b>	INDEX NO. <b>13417</b>	SHEET NO. <b>1 of 1</b>
---------------	----------	--------------	--	---	---------------------------	----------------------------