

C:\projects\standards\roadway\02200-s\02261-01.dgn
 4:52:37 PM
 sm970re
 6/24/2013

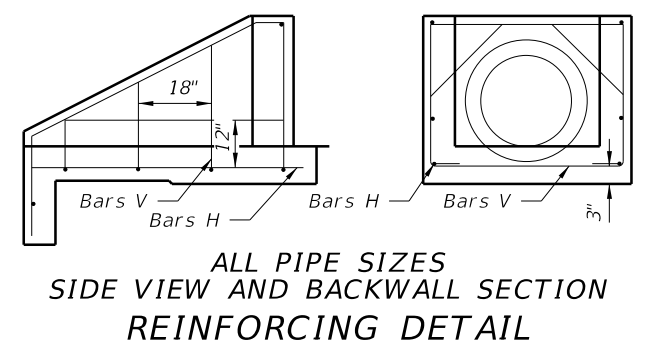
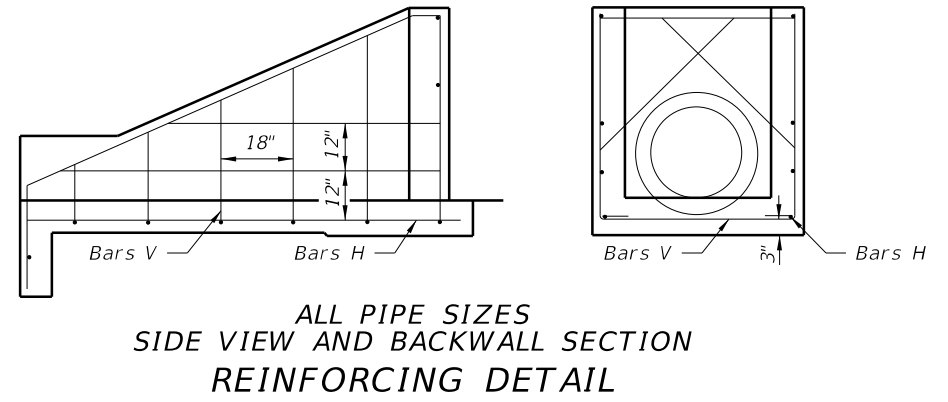
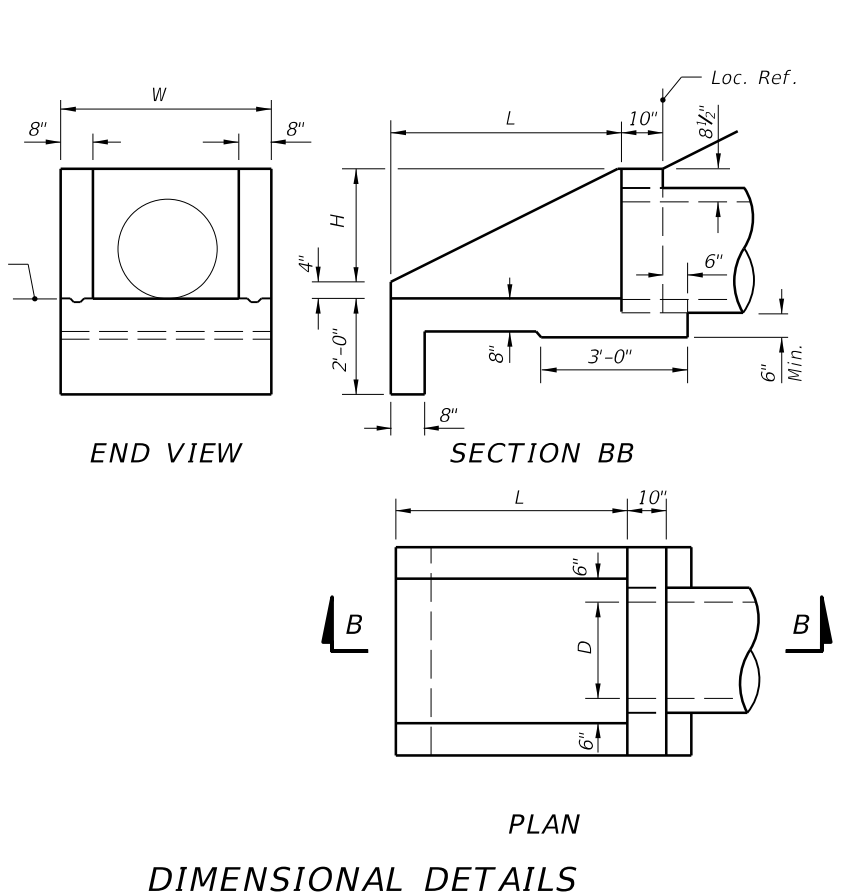
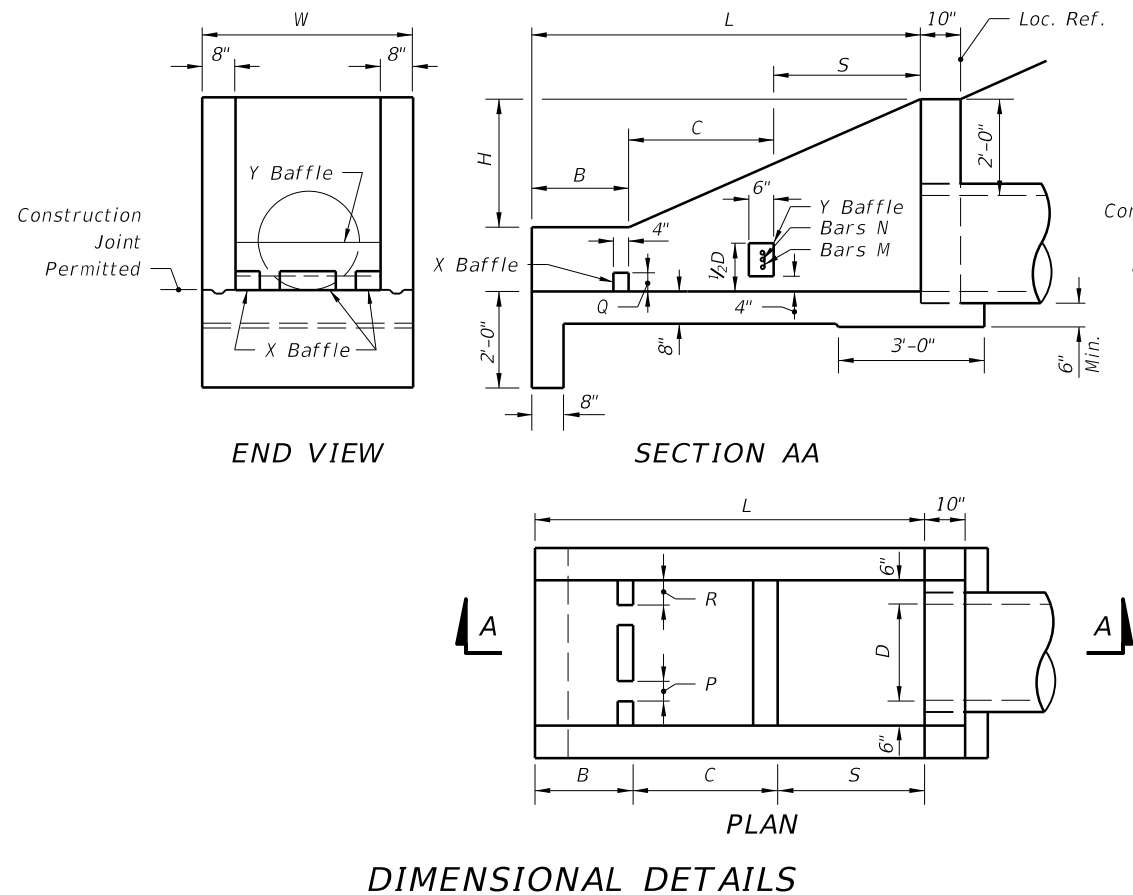

GENERAL NOTES

1. Baffles to be constructed only when called for in plans.
2. When steel grating is required on endwall see Sheet 3 of 3 for details.
3. All reinforcing No. 4 bars with 2" clearance except as noted.
4. All angles, channels and bars shall be ASTM A242/A242M, A572/A572M or A588/A588M Grade 50 steel. When designated Alternate G in the plans galvanize in accordance with Section 975 and 425-3.2 of the Standard Specifications.
5. Channel section C 3x6 may be substituted for C 4x5.4 channel.
6. Precasting of this endwall will be permitted. Precast units shall conform to the dimensions shown or in accordance with approved shop drawings. Request for shop drawing approval shall be directed to the State Drainage Engineer. Use Index No. 201 for opening and grouting details.
7. Concrete shall be Class I, except ASTM C478 (4000 psi) concrete may be substituted for precast items manufactured in plants meeting the requirements of Section 449 of the Specifications.
8. Sodding shall be in accordance with Index No. 281, and paid for under the contract unit price for Performance Turf, SY.
9. Endwall to be paid for under the contract unit price for U-Endwall, Each. Payment shall include cost of concrete, reinforcing steel, and when called for in the plans, steel grating, baffles and accessories. Quantities shown are for estimating purposes only.

DIMENSIONS AND QUANTITIES FOR ONE U-ENDWALL														
Pipe Size		L	H	W	S	B	C	X Baffle			Y Baffle Reinf. Steel		Class I Conc. Cu. Yd.	Reinf. Steel Lbs.
D	Area Sq. Ft.							P	Q	R	Bar M	Bar N		
15"	1.23	5'-9"	2'-3 1/2"	3'-7"	2'-3"	1'-3"	2'-3"	4"	4"	4"	2 #4	1 #4	1.61	72
18"	1.77	6'-6"	2'-5"	3'-10"	2'-6"	1'-6"	2'-6"	4"	4"	5"	3 #4	2 #4	1.89	86
24"	3.14	8'-0"	2'-8"	4'-4"	3'-0"	2'-0"	3'-0"	5"	5"	6"	4 #4	3 #4	2.52	108
30"	4.91	9'-6"	2'-11"	4'-10"	3'-6"	2'-6"	3'-6"	5"	5"	7"	4 #4	4 #4	3.34	131

DIMENSIONS AND QUANTITIES FOR ONE U-ENDWALL						
Pipe Size		L	H	W	Class I Conc. Cu. Yd.	Reinf. Steel Lbs.
D	Area Sq. Ft.					
15"	1.23	3'-3"	1'-7 1/2"	3'-7"	0.89	39
18"	1.77	3'-9"	1'-10 1/2"	3'-10"	1.05	43
24"	3.14	4'-9"	2'-4 1/2"	4'-4"	1.40	55
30"	4.91	5'-9"	2'-10 1/2"	4'-10"	1.88	64

WITH BAFFLES

WITHOUT BAFFLES

ENDWALLS FOR 1:2 SLOPES

C:\projects\standards\roadway\0200-s\02061-02.dgn
 smg70re
 4:52:39 PM
 6/24/2013

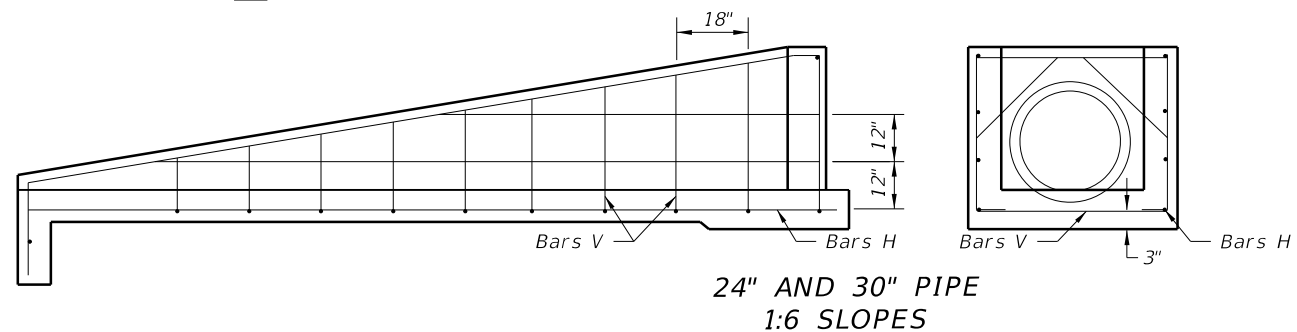
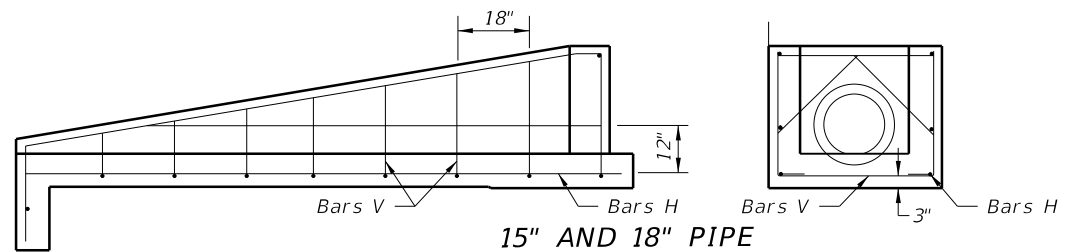
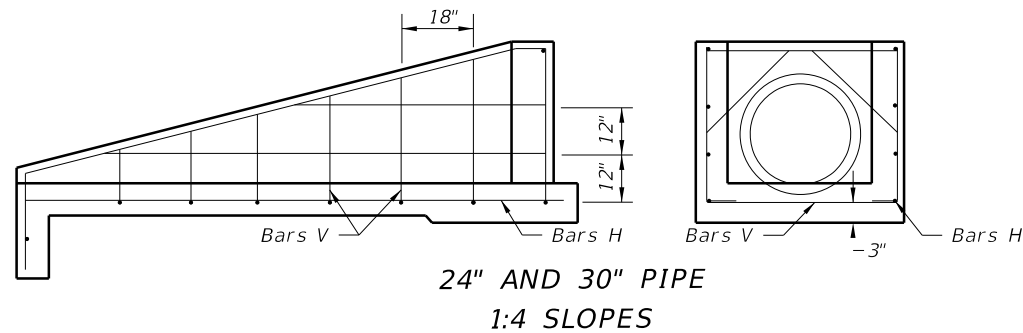
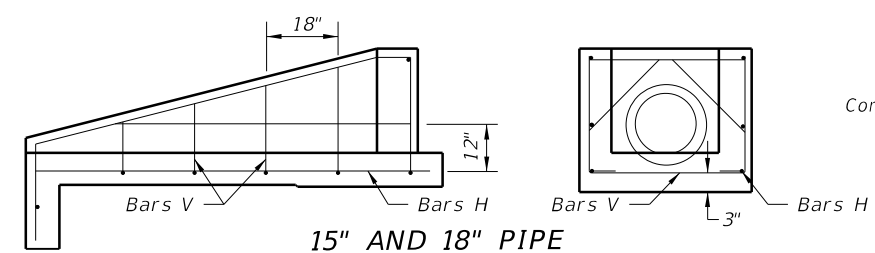
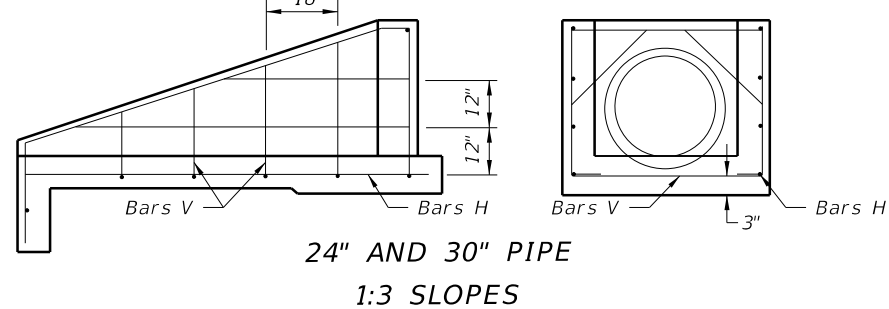
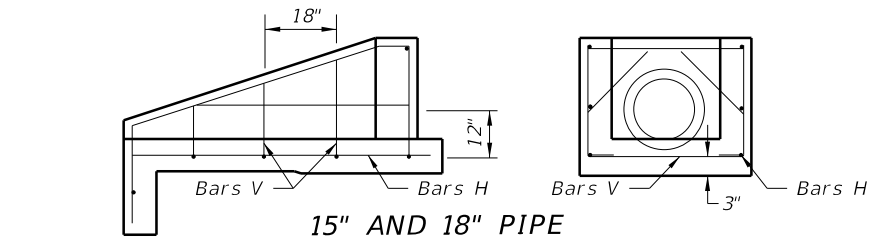
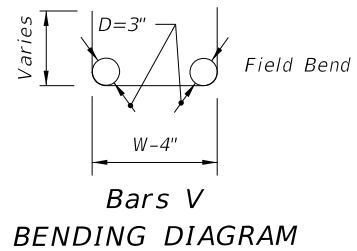
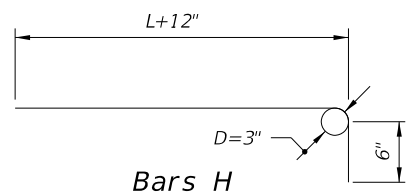

**SIDE VIEWS AND BACKWALL SECTIONS
REINFORCING DETAILS**

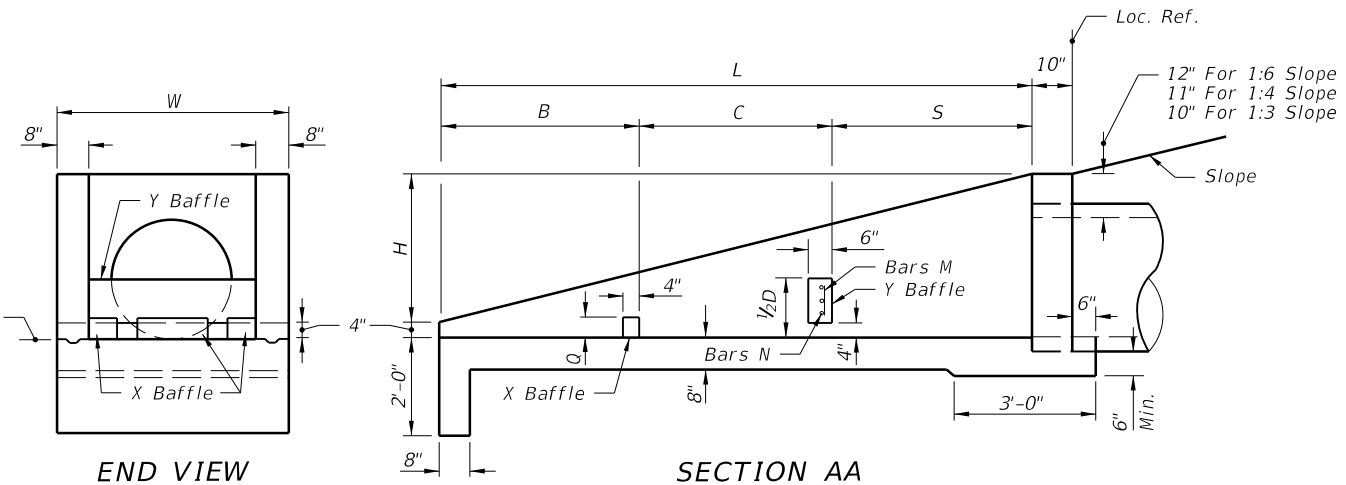
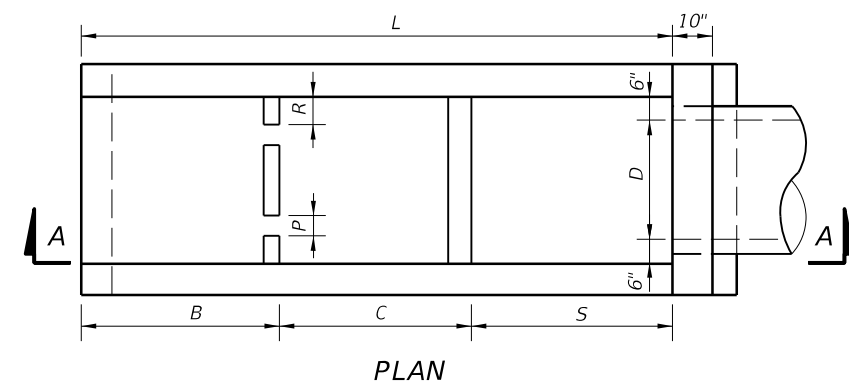

DIMENSIONAL DETAILS

DIMENSIONS AND QUANTITIES FOR BAFFLES							
Pipe Size D	X Baffle			Ybaffle Reinf. Steel		Class I Concrete Cu. Yd.	Reinf. Steel Lbs
	P Width	Q Height	R Length	Bar M	Bar N		
15"	4"	4"	4"	2- #4	1- #4	0.10	4
18"	4"	4"	5"	3- #4	2- #4		8
24"	5"	5"	6"	4- #4	3- #4		12
30"	5"	5"	7"	4- #4	4- #4		16

DIMENSIONS AND QUANTITIES FOR ONE U-ENDWALL										
Rate Of Slope	Pipe Size		L	H	W	Baffle Locations (When Required)			Class I Concrete Cu. Yd.	Reinf. Steel Lbs.
	D	Area (Sq. Ft.)				S	B	C		
1:3	15"	1.23	5'-3"	1'-9"	3'-7"	1'-9"	1'-9"	1'-9"	1.19	51
	18"	1.77	6'-0"	2'-0"	3'-10"	2'-0"	2'-0"	2'-0"	1.42	56
	24"	3.14	7'-6"	2'-6"	4'-4"	2'-6"	2'-6"	2'-6"	1.94	77
	30"	4.91	9'-0"	3'-0"	4'-10"	3'-0"	3'-0"	3'-0"	2.54	96
1:4	15"	1.23	7'-4"	1'-10"	3'-7"	2'-6"	2'-6"	2'-4"	1.54	64
	18"	1.77	8'-4"	2'-1"	3'-10"	2'-10"	2'-10"	2'-8"	1.84	71
	24"	3.14	10'-4"	2'-7"	4'-4"	3'-6"	3'-6"	3'-4"	2.53	92
	30"	4.91	12'-4"	3'-1"	4'-10"	4'-2"	4'-2"	4'-0"	3.34	124
1:6	15"	1.23	11'-6"	1'-11"	3'-7"	3'-10"	3'-10"	3'-10"	2.19	89
	18"	1.77	13'-0"	2'-2"	3'-10"	4'-4"	4'-4"	4'-4"	2.63	103
	24"	3.14	16'-0"	2'-8"	4'-4"	5'-4"	5'-4"	5'-4"	3.59	143
	30"	4.91	19'-0"	3'-2"	4'-10"	6'-4"	6'-4"	6'-4"	4.81	180

ENDWALLS WITH AND WITHOUT BAFFLES FOR 1:3, 1:4 AND 1:6 SLOPES

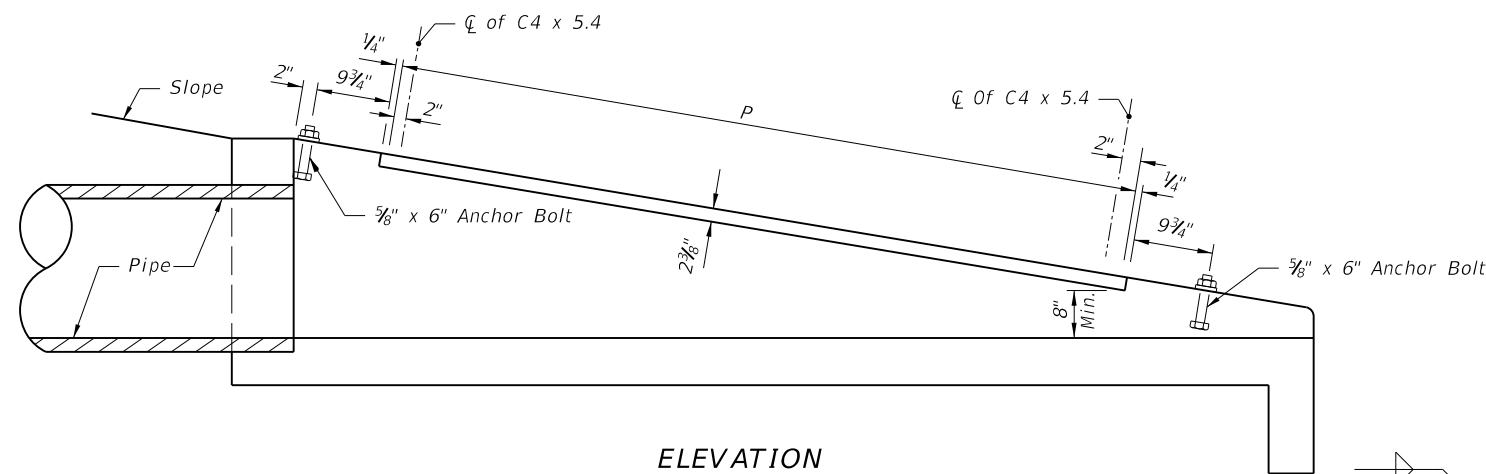

ELEVATION

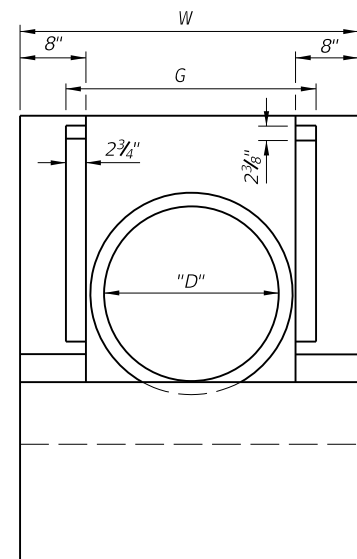

END VIEW

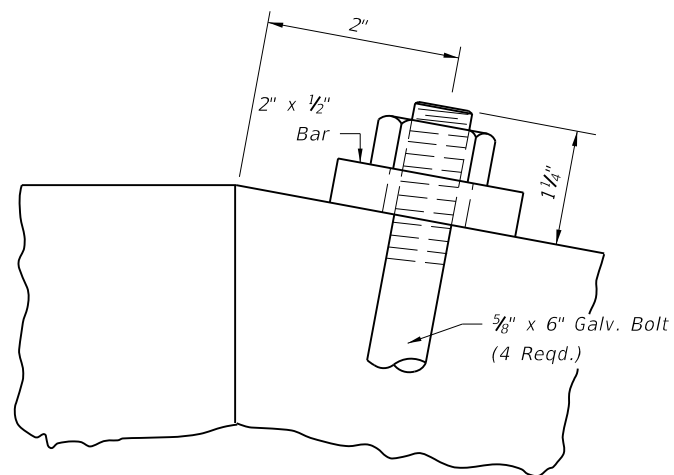

ANCHOR BOLT DETAIL

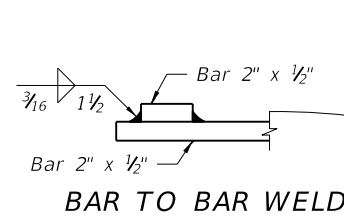

BAR TO BAR WELD

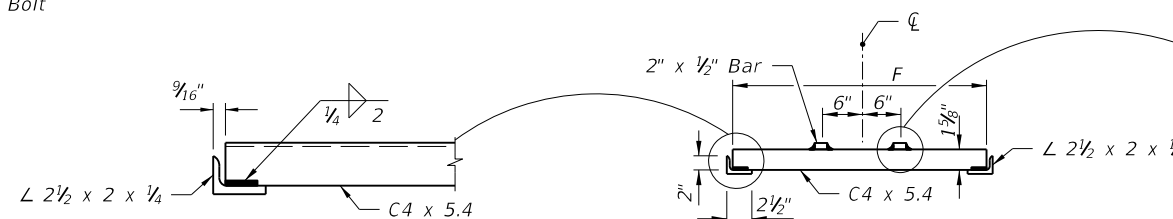

CHANNEL TO ANGLE WELD

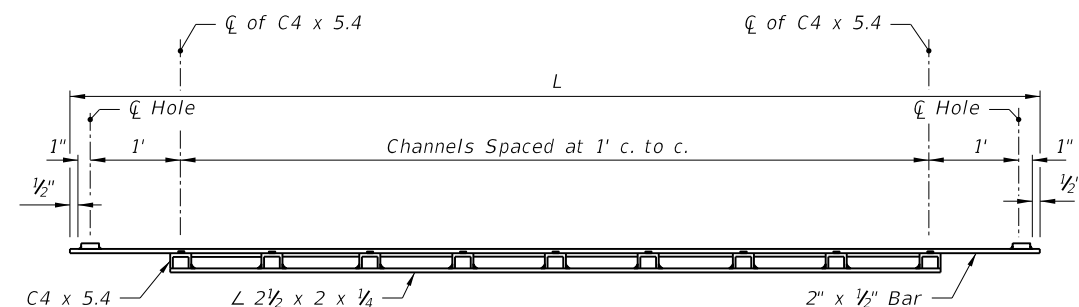

SECTION AA

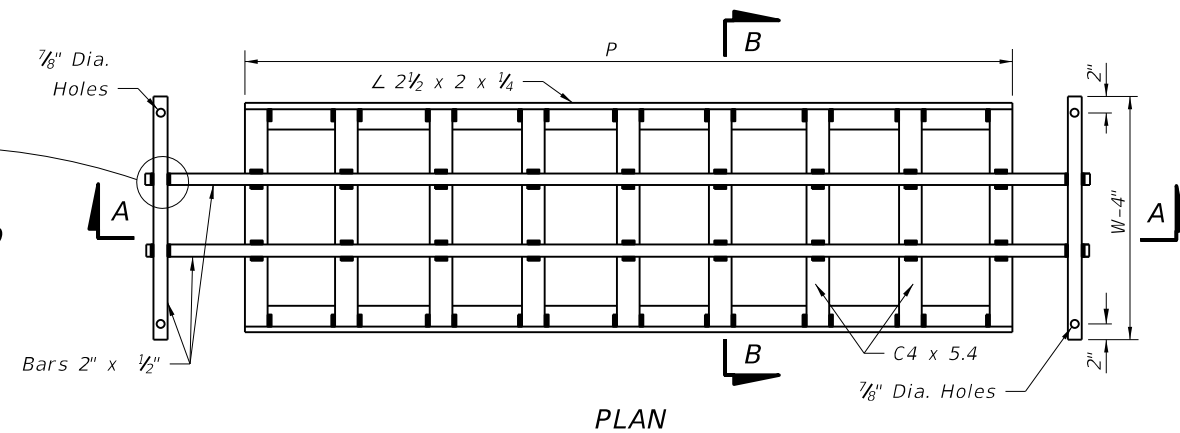

PLAN

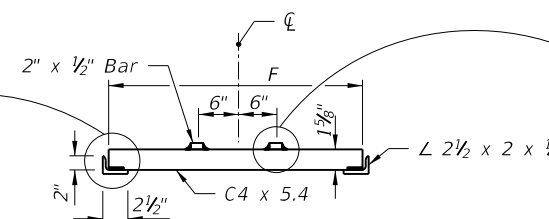

SECTION BB

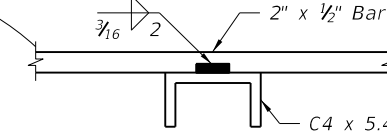

BAR TO CHANNEL WELD

STEEL GRATE

MOUNTING FOR STEEL GRATE

TABLE OF DIMENSIONS AND QUANTITIES FOR ONE GRATE											
Rate Of Slope	Size Pipe D	G	2 Each Bars @ 3.4 lb/ft			(X) Channels @ 5.4 lb/ft			2 Angles @ 3.62 lb/ft		Total Weight (lb)
			L	W-4"	lb	(X)	F	lb	P	lb	
1:6	15"	2' -8 1/2"	9'-3"	3'-3"	85	8	2' -6 7/8"	111	7'-4"	53	249
	18"	2' -11 1/2"	10'-3"	3'-6"	94	9	3' -9 7/8"	137	8'-4"	62	292
	24"	3' -5 1/2"	13'-3"	4'-0"	117	12	3' -3 7/8"	215	11'-4"	82	414
	30"	3' -11 1/2"	16'-3"	4'-6"	141	15	3' -9 7/8"	310	14'-4"	104	555
1:4	15"	2' -8 1/2"	6'-3"	3'-3"	65	5	2' -6 7/8"	70	4'-4"	32	167
	18"	2' -11 1/2"	7'-3"	3'-6"	73	6	2' -9 7/8"	92	5'-4"	39	204
	24"	3' -5 1/2"	9'-3"	4'-0"	90	8	3' -3 7/8"	144	7'-4"	53	287
	30"	3' -11 1/2"	11'-3"	4'-6"	107	10	3' -9 7/8"	206	9'-4"	68	381
1:3	15"	2' -8 1/2"	4'-3"	3'-3"	51	3	2' -6 7/8"	42	2'-4"	17	110
	18"	2' -11 1/2"	5'-3"	3'-6"	60	4	2' -9 7/8"	61	3'-4"	24	145
	24"	3' -5 1/2"	6'-3"	4'-0"	70	5	3' -3 7/8"	90	4'-4"	31	191
	30"	3' -11 1/2"	8'-3"	4'-6"	87	7	3' -9 7/8"	145	6'-4"	46	278

STEEL GRATING USE CRITERIA

- Grates to be used on pipe culvert endwalls located within the designated clear zone. Positive debris control shall be provided at all upgradient openings. Grates shall not be used unless one or more of the following conditions exist:
 - Drainage area to culvert consists of median or infield areas or areas where debris and/or drift is negligible.
 - Runoff to culvert is by sheet flow or in such ill defined channels that debris transport is not considered a major problem.
 - Runoff to culvert is minor except on an infrequent basis (10 to 15 year frequency); for example a drainage basin in flat sandy terrain with normally low ground water table.
 - Areas where culvert blockage with resultant backwater would not seriously affect roadway embankment, traffic operation or upland property.
- Steel grating to be used only where called for in plans.

C:\projects\standards\roadway\00200-s\00261-03.dgn 6/24/2013 4:52:41 PM sm970re