

C:\projects\standards\roadway\02200-s\02240-01.dgn
 sm970re
 4:46:55 PM
 6/24/2013

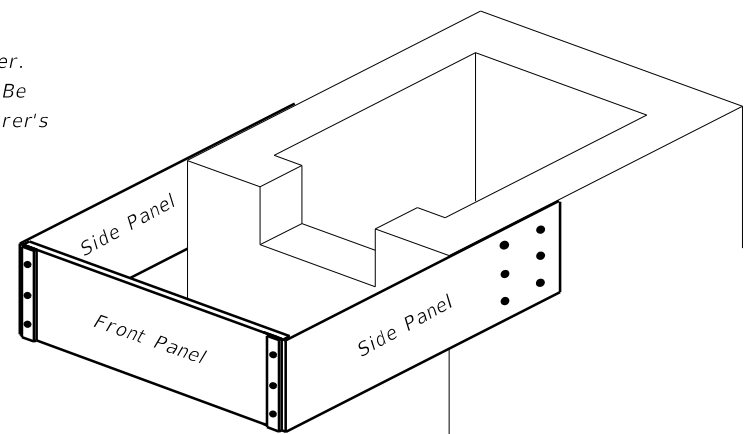
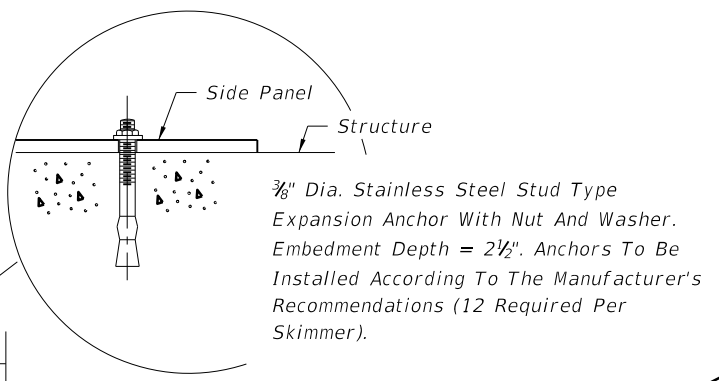
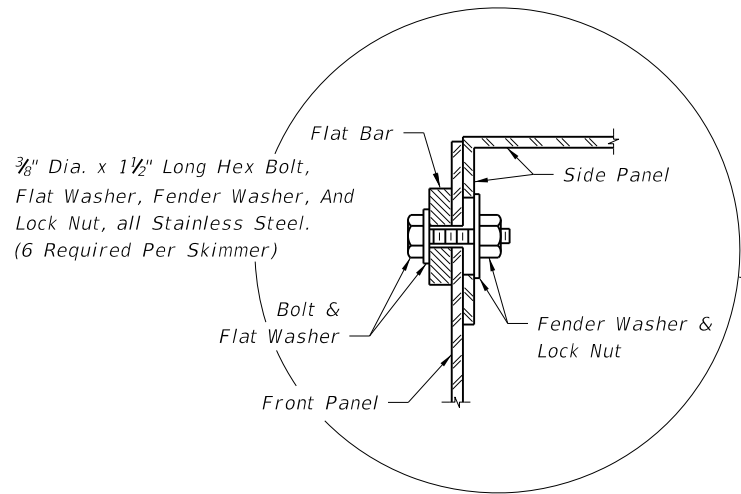

PICTORIAL VIEW

GENERAL NOTES

1. This skimmer is intended for use on Type C, D, or E Ditch Bottom Inlets that are used as outlet control structures of stormwater management facilities.
2. The side panels are dimensionally symmetric, therefore they may be used on either side of the structure.
3. Two (2) skimmers may be constructed on one structure provided they are on opposite ends.
4. The width of the front panel (dimension W) shall be the same as the outside dimension across the front of the structure.
5. The front panel, side panels, and flat bars are to be hot dip galvanized after fabrication.
6. The location of the reinforcing steel in these structures must conform to the applicable standards to avoid conflict with the expansion anchors used to attach the skimmer.
7. Grates to be used on the inlets unless otherwise specified in the plans.
8. A skimmer consists of two (2) side panels, one front panel, two (2) flat bars, and accessory hardware. The cost of skimmers is to be included in the cost of the inlet.

DESIGN NOTES

1. The designer must specify, in the plans, the skimmer height (dimension H) and the sides where the weir slots and skimmers are located. The skimmer height must be one of the dimensions shown in the table on Sheet 2. The skimmer should not be used on structure sides with outside dimensions greater than 6'-4".
2. To minimize hydraulic losses across the skimmer, the flow area under the skimmer should be three times larger than the flow area of the weir slot. The distance between the pond bottom at the structure and the skimmer shall be not less than 1 foot.
3. The configuration of skimmers may be subject to regulatory requirements. The designer should coordinate the outlet control structure details with the permitting agencies.
4. Where this skimmer is used, the designer should reference this index with the outlet control structure details. Where a different skimmer design is needed, the designer should provide skimmer details in the plans.
5. The designer shall evaluate if a grate is needed for safety reasons. Where a grate is not needed for safety reasons and is not desirable for hydraulic or other reasons, the designer may omit the grate by stating so in the outlet control structure details.
6. The designer must show the configuration of the weir slots in the outlet control structure detail.

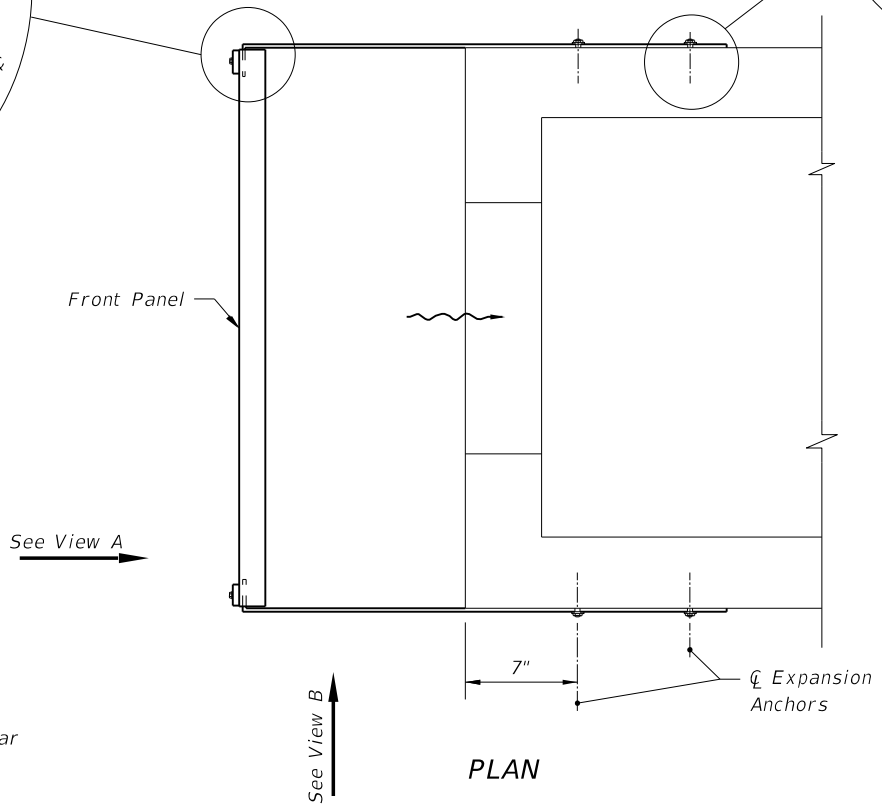

PLAN

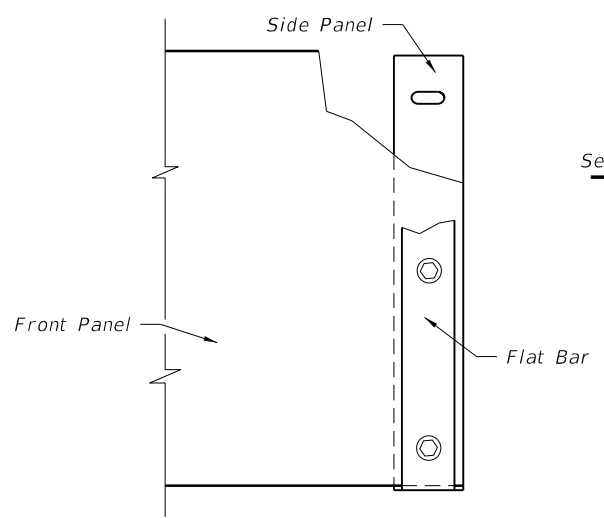

VIEW A

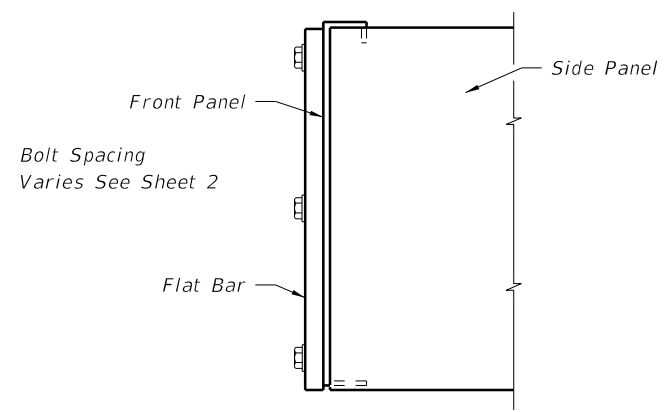

VIEW B

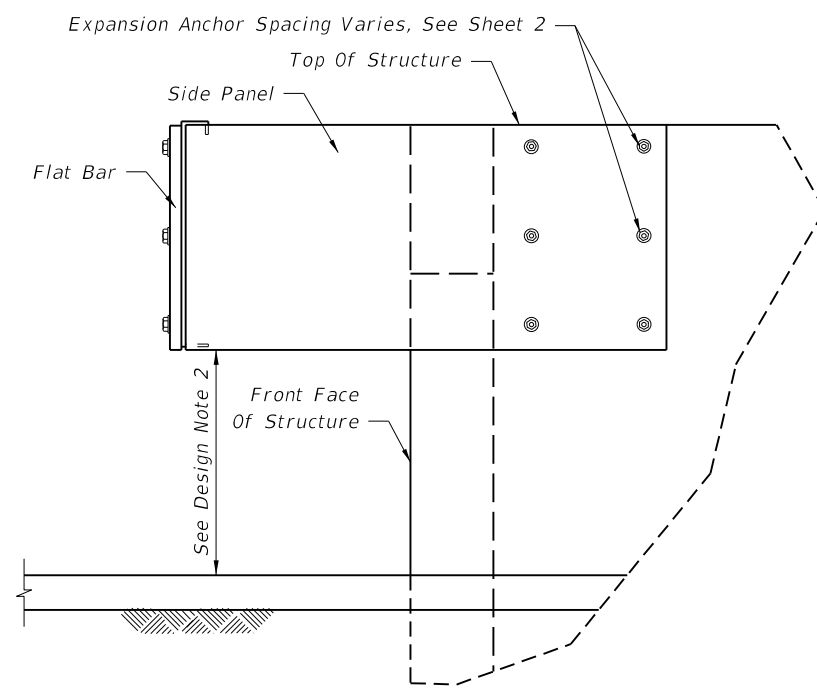

SIDE VIEW

LAST REVISION 07/01/13	REVISION	DESCRIPTION:	 <p>FDOT 2014 DESIGN STANDARDS</p>	<p>SKIMMER FOR OUTLET CONTROL STRUCTURES</p>	<p>INDEX NO. 240</p>	<p>SHEET NO. 1 of 2</p>
---------------------------	----------	--------------	---	--	--------------------------	-----------------------------

DIMENSIONS				
Skimmer Height as Specified in the Plans				Bolt Spacing
H	D	E	L	S
Inches				
12	3 $\frac{3}{16}$	3	28	3
14	3 $\frac{3}{16}$	3	28	4
16	3 $\frac{3}{16}$	3	28	5
18	3 $\frac{3}{16}$	3	28	6
20	4 $\frac{3}{16}$	4	31	6
22	4 $\frac{3}{16}$	4	31	7
24	4 $\frac{3}{16}$	4	31	8
26	4 $\frac{3}{16}$	4	31	9
28	4 $\frac{3}{16}$	4	31	10
30	5 $\frac{3}{16}$	5	31	10
32	5 $\frac{3}{16}$	5	31	11
34	5 $\frac{3}{16}$	5	31	12
36	6 $\frac{3}{16}$	6	31	12
38	6 $\frac{3}{16}$	6	31	13
40	6 $\frac{3}{16}$	6	31	14

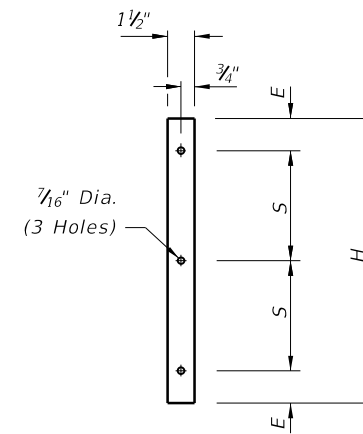

1/4" Thick x 1 1/2" Wide
FLAT BAR

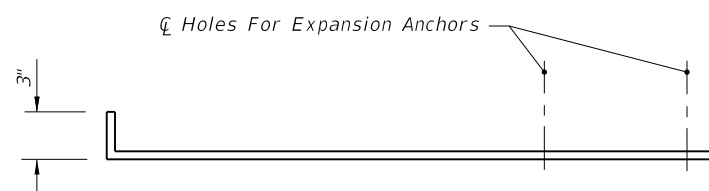

TOP VIEW

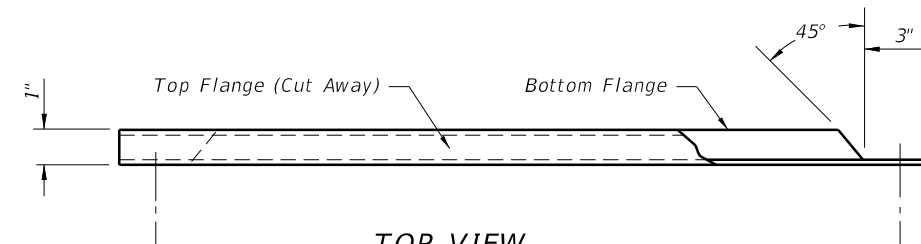

TOP VIEW

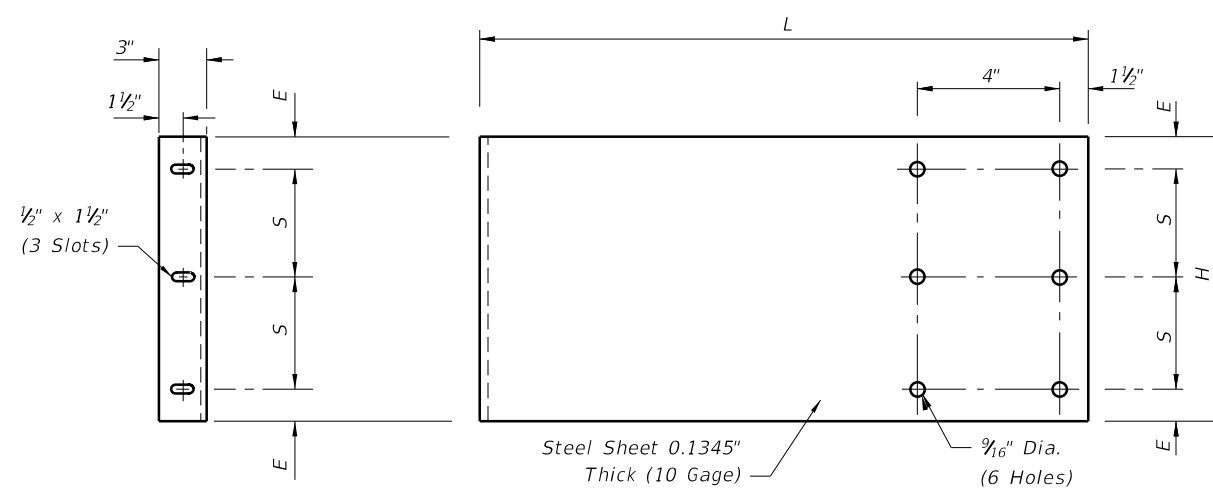

END VIEW (FRONT)

SIDE VIEW

SIDE PANEL

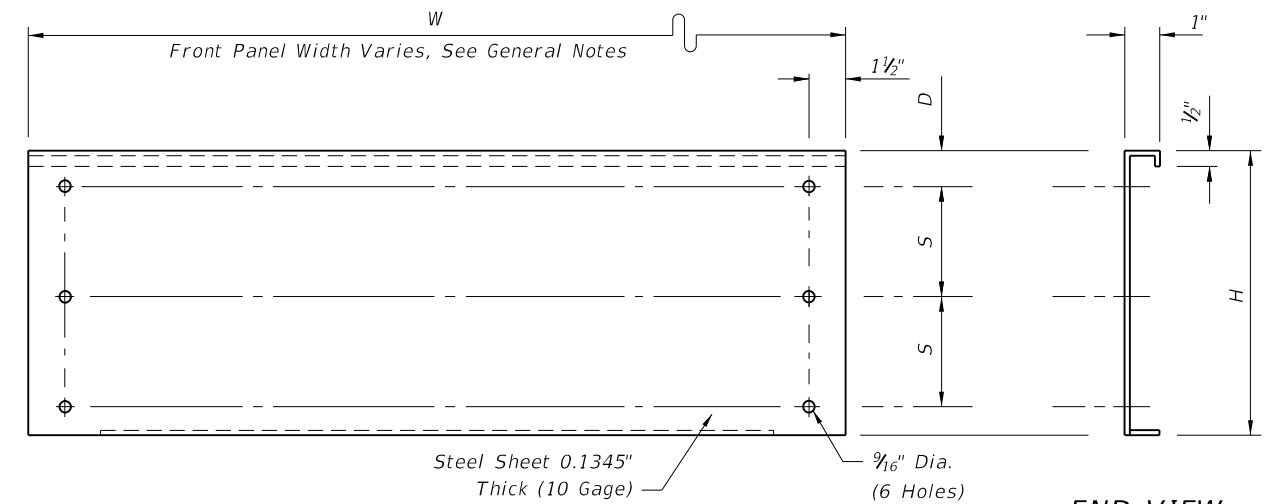

FRONT VIEW

END VIEW

FRONT PANEL

6/24/2013 4:46:57 PM sm970re C:\projects\standards\roadway\0200-s\02040-02.dgn

LAST REVISION
01/01/12

REVISION DESCRIPTION:



FDOT 2014
DESIGN STANDARDS

SKIMMER FOR OUTLET CONTROL STRUCTURES

INDEX NO.
240

SHEET NO.
2 of 2