

PLAN
(CAST-IN-PLACE INLET SHOWN, WITHOUT GRATE, PRECAST INLET SIMILAR)

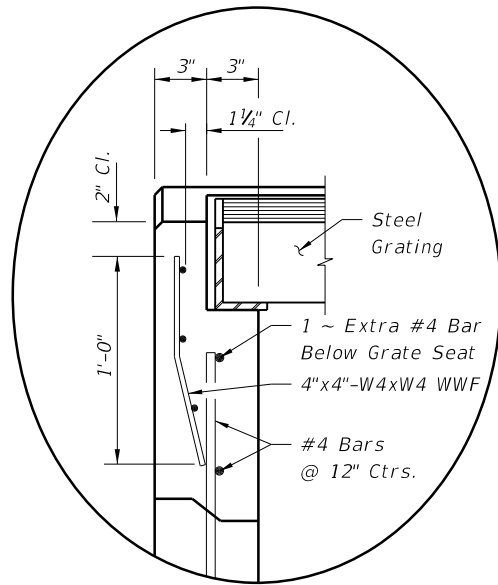

INSET A
(PRECAST OPTION)

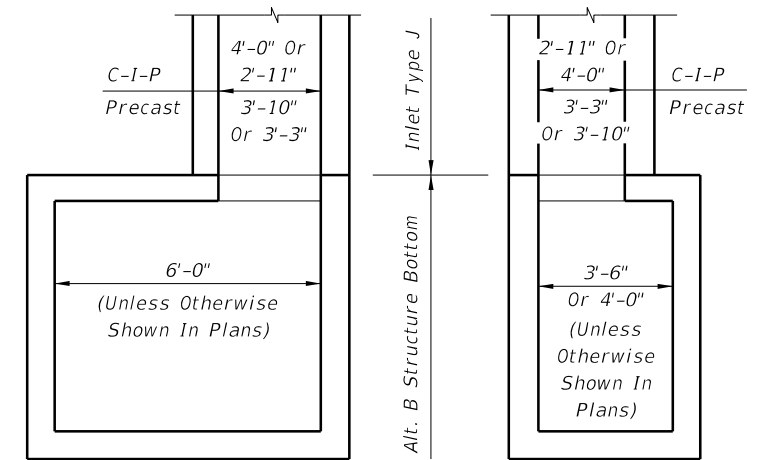

NOTE: Alt. B Structure Bottom Only. See Index No. 200 for structure bottom details and hole reinforcement.

INLET WITH STRUCTURE BOTTOM

HORIZONTAL WALL REINFORCING SCHEDULE (TABLE 1)

WALL DEPTH	SCHEDULE	AREA (In ² /ft)	MAX. SPACING	
			BARS	WWF
0' - 4'	A12	0.20	12"	8"
4' - 9'	A6	0.20	6"	5"
9' - 12'	A4	0.20	4"	3"
9' - 15'	B5.5	0.24	5 1/2"	5"

RECOMMENDED MAXIMUM PIPE SIZES

INLET INSIDE WIDTH	PIPE SIZE
2'-11" or 3'-3"	24"
3'-10" or 4'-0"	30"

Note: Recommended sizes are for concrete pipe. Sizes for other types of pipe must be verified for fit in accordance with Index No. 201. For larger pipe, see Structure Bottom detail above and Index No. 200.

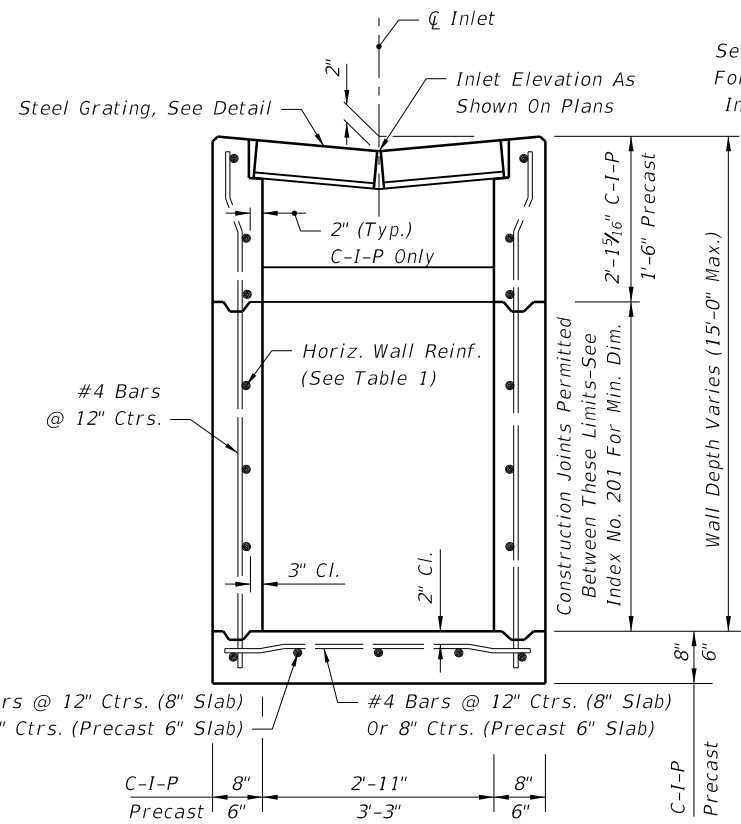

(Pipe Opening Not Shown)
SECTION BB

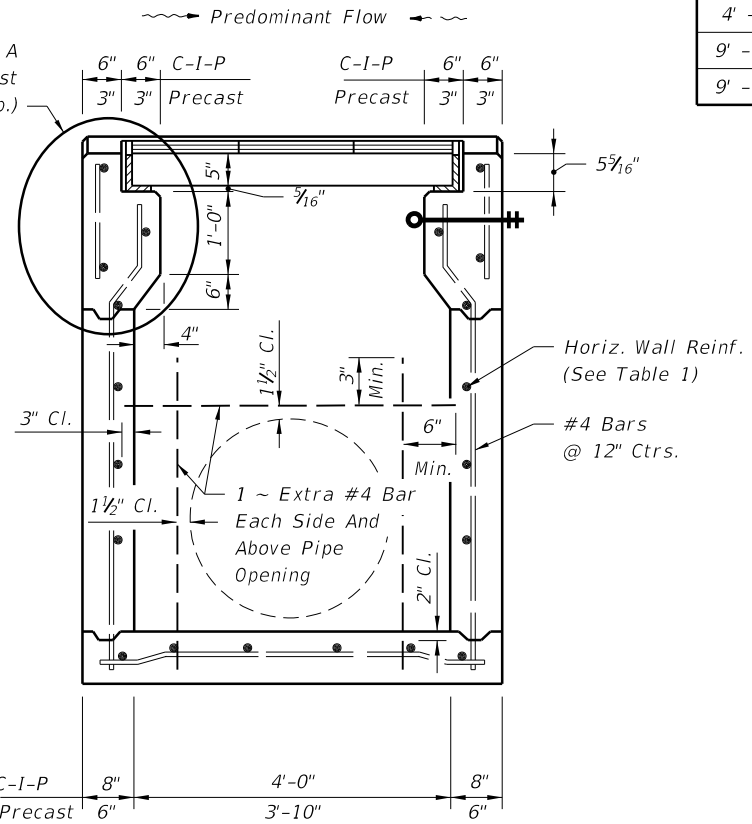

(Pipe Opening Shown)
SECTION AA

GENERAL NOTES

1. This inlet is designed for use in ditches, medians, pavement areas or other areas subject to heavy wheel loads with minimal debris. This inlet is not for use in areas subject to bicycle traffic. This inlet may be placed in areas subject to occasional pedestrian traffic such as landscaped areas and pavement areas where pedestrians can walk around the inlet.
2. All reinforcing Grade 60 bars with 2" min. cover unless otherwise noted. See Index No. 201 for equivalent area of welded wire fabric. Cut or bend bars out of way of pipe when necessary; bars to clear pipe by 1 1/2".
3. All exposed edges and corners shall be 3/4" chamfer or tooled to 1/4" radius.
4. When alternate G grate is specified in plans the grate is to be hot dip galvanized after fabrication.
5. For supplemental details, see Index No. 201.
6. All dimensions are for both precast and cast-in-place inlets unless otherwise noted.
7. Cost of ditch paving to be included in cost of inlet. Sodding to be paid for under contract unit price for Performance Turf, SY.

C:\projects\standards\roadway\02200-s\02234-01.dgn
smg970re
4:45:43 PM
6/24/2013

C:\projects\standards\roadway\02200-s\02234-02.dgn
 sm970re
 4:45:45 PM
 6/24/2013

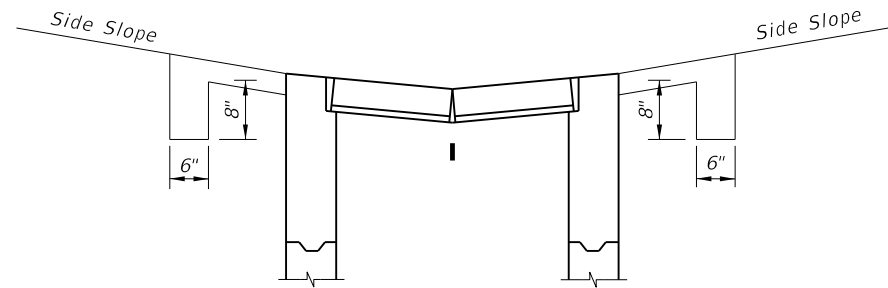

SECTION CC

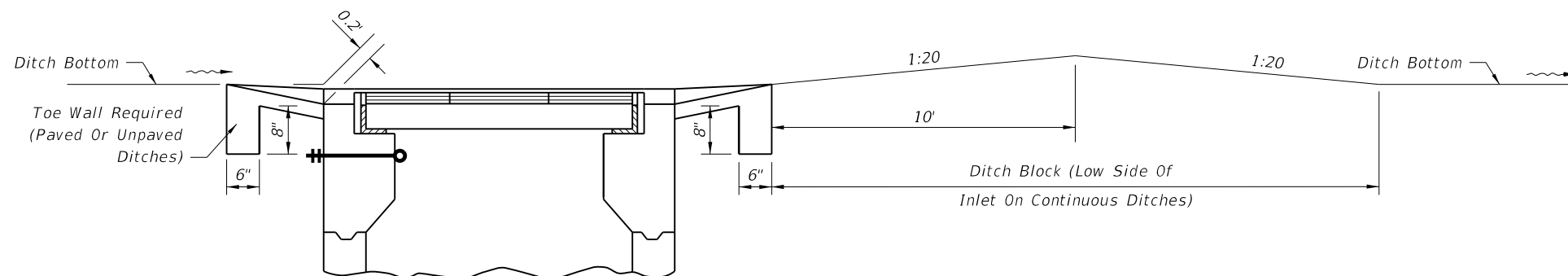

SECTION DD

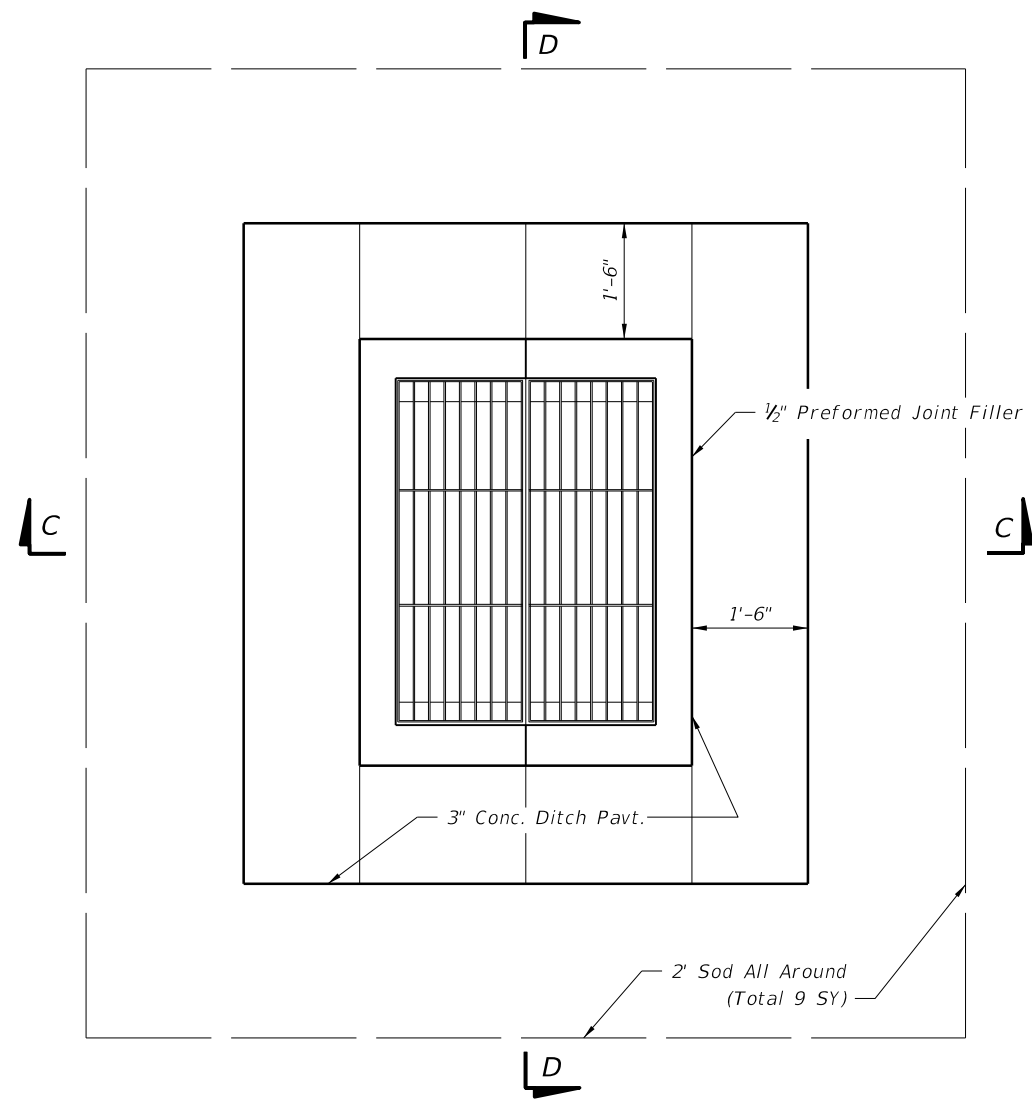

PAVEMENT & SODDING

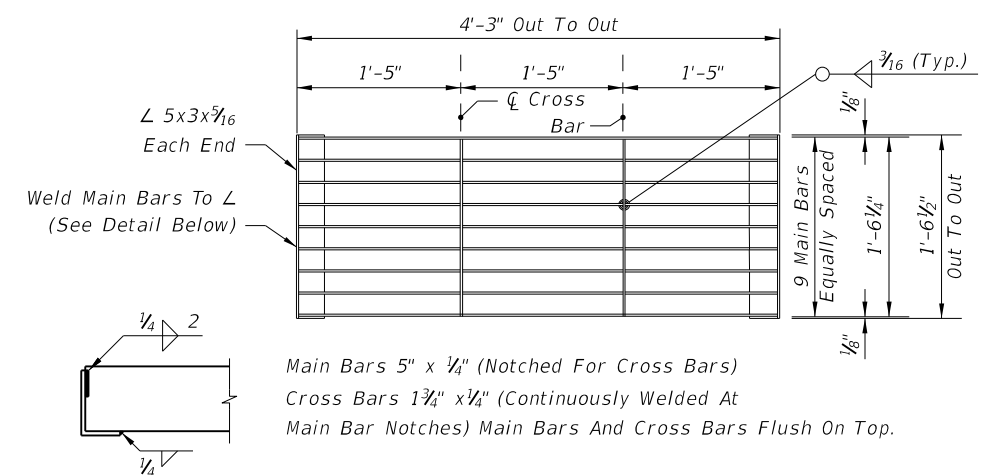

DETAIL

STEEL GRATING

LAST REVISION
07/01/09

REVISION

DESCRIPTION:



FDOT 2014
DESIGN STANDARDS

DITCH BOTTOM INLET TYPE J

INDEX NO.
234

SHEET NO.
2 of 2