

NOTE:
Not Applicable For Type A, B, C, D & E Ditch
Bottom Inlets Or Type S & V Gutter Inlets.
See Index Nos. 220, 221, 230, 231 & 232.

TOP SLAB REINFORCING STEEL DIAGRAM
(ALTERNATE A)

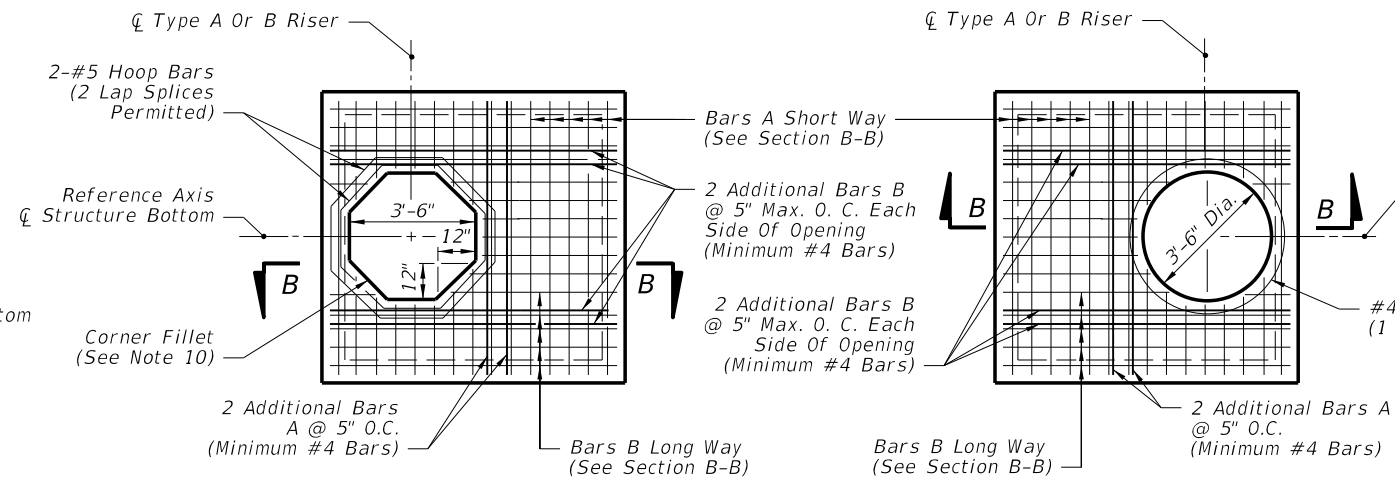

SQUARE OPENING WITH CORNER FILLETS

ROUND RISER OPENING

TOP SLAB REINFORCING STEEL DIAGRAM
(ALTERNATE B)

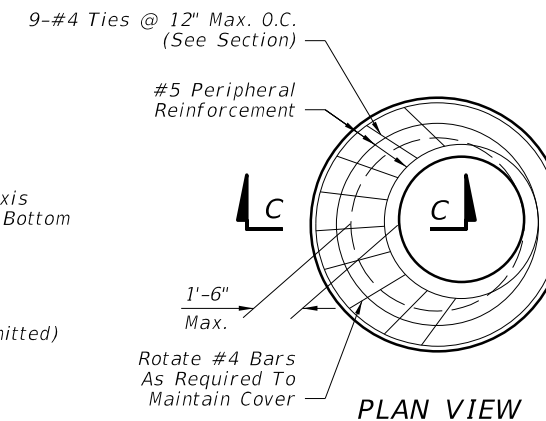

PLAN VIEW

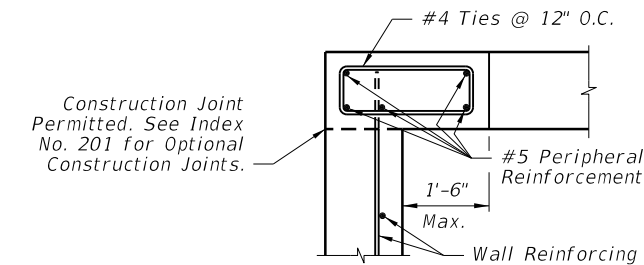

SECTION C-C
SPECIAL TOP SLAB*

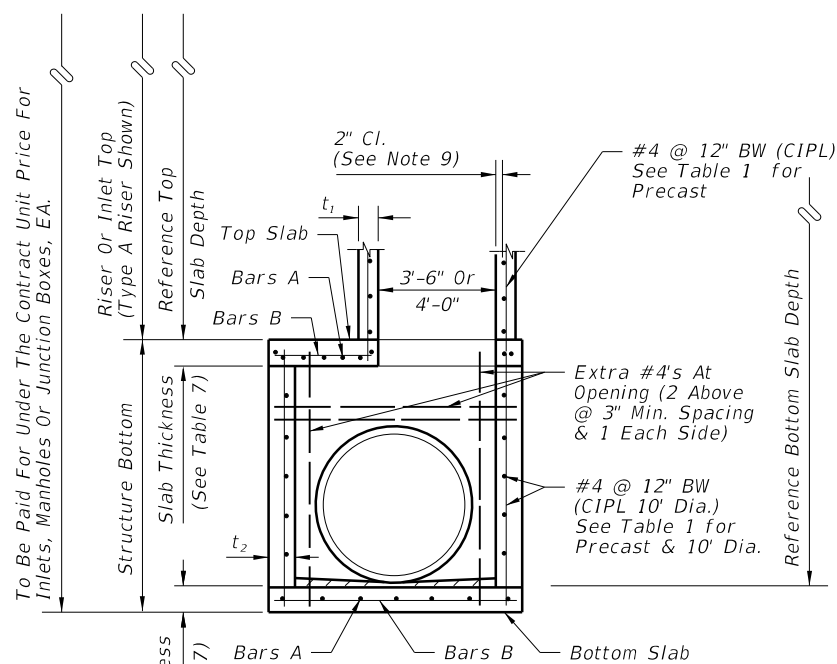

SECTION A-A
(ALTERNATE A)

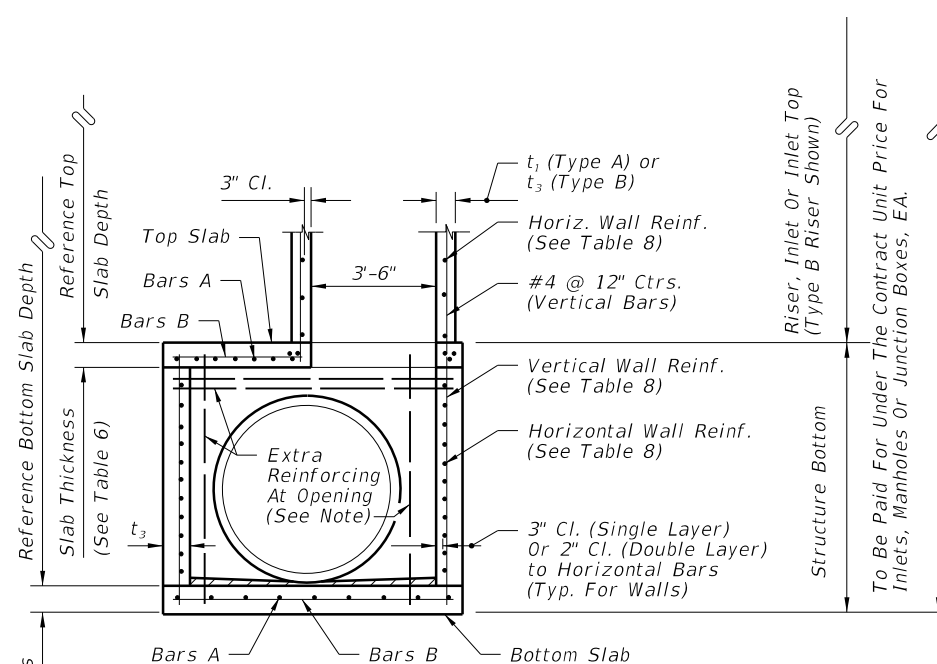

SECTION B-B
(ALTERNATE B)

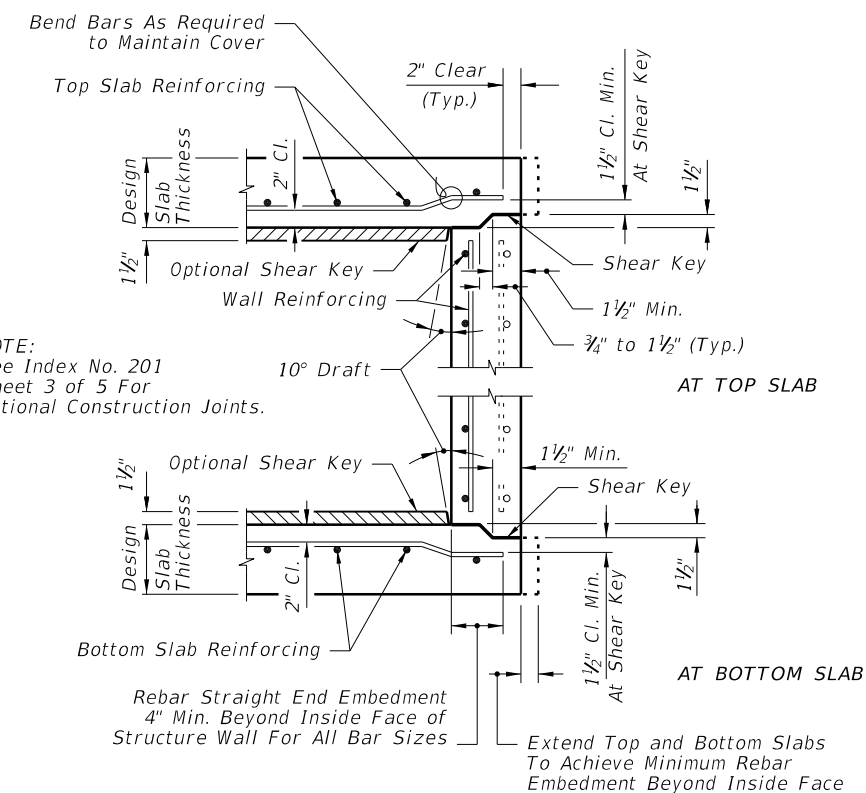

TYPICAL SLAB TO WALL DETAILS
FOR PRECAST STRUCTURES

*NOTE:
When the inside diameter of a round structure is
not more than 1'-6" larger than the opening in the
riser or top slab, the top of the structure or riser shall
be constructed according to the "Special Top Slab"
details on this sheet.

NOTE:
Provide one extra #4 bar reinforcement each side of each opening
and two extra #4 bars at 3" min. spacing above each opening.

NOTE:
See Index No. 201
Sheet 3 of 5 For
Optional Construction Joints.

C:\projects\standards\roadway\02200-s\02200-01.dgn 6/24/2013 4:33:34 PM sm970re

LAST REVISION 01/01/10	DESCRIPTION:	 FDOT 2014 DESIGN STANDARDS	STRUCTURE BOTTOMS TYPE J AND P	INDEX NO. 200	SHEET NO. 1 of 5

GENERAL NOTES

ROUND STRUCTURE BOTTOMS (ALTERNATE A) & ROUND RISERS- TABLE 1									
Wall Thickness (t ₁ & t ₂) and Vertical & Horizontal Areas of Reinforcement (A _s)									
Type	Structure/Riser Diameter (ft)	Cast-In-Place Items Class II Concrete			Precast Items				
		t ₁ Riser (in.)	t ₂ Bottom (in.)	A _s (in. ² /ft.)	Class II Concrete			ASTM C478	
					t ₁ Riser (in.)	t ₂ Bottom (in.)	A _s (in. ² /ft.)	t ₁ or t ₂ (in.)	A ₂ *** (in. ² /ft.)
P	3'-6"	6	8	0.20	6	8	0.20	4**	0.105
P	4'-0"	6	8	0.20	6	8	0.20	5**	0.120
J	5'-0"	-	8	0.20	-	8	0.20	6**	0.150
J	6'-0"	-	8	0.20	-	8	0.20	6	0.180
J	7'-0"	-	8	0.20	-	8	0.20	7	0.210
J	8'-0"	-	8	0.20	-	8	0.20	8	0.240
J	10'-0"	-	10	0.40##	-	10	0.40##	10	0.300
J	12'-0"	-	10	0.40##	-	12	0.40##	12	0.360

TABLE 1 NOTES:

##Provide 0.20 eq. in.²/ft. at each face, 12" max. bar spacing.
 **Modified minimum wall thickness.
 ***Min. total circumferential reinforcement for continuous steel hoops:
 A₂ = 0.50 sq. in. for riser section height equal or less than 2'-0" (2 hoop min.)
 A₂ = 0.75 sq. in. for riser section height more than 2'-0" up to 4'-0" (3 hoop min.)
 Areas of reinforcing for precast items are based on Grade 60 reinforcing;
 No reduction in the area of reinforcement is allowed for welded wire fabric in Table 1;
 Area of vertical reinforcing may be reduced in accordance with ASTM C478.

SQUARE & RECTANGULAR STRUCTURES (ALTERNATE B) - TABLE 2				
Type	Wall Length (ft)	Max. Depth (ft)	Wall Thickness (t _s)	
			CIP (in.)	Precast (in.)
P	≤ 3'-6"	40	6 Riser 8 Bottom	6
J	4'-0"	40	8	6
J	5'-0"	22	-	6
J	6'-0"	15	-	6
J	5'-0" to 9'-0"	40	8	8
J	10'-0"	26	8	8
J	10'-0" to 12'-0"	40	10	9
J	16'-0"	35	-	9
J	16'-0"	40	10	10
J	20'-0"	25	-	9
J	20'-0"	30	10	10

TABLE 2 NOTES:
 See Table 8 for Reinforcing Schedule.

- Standard structure bottoms 4'-0" diameter and smaller (Alt. A) and 3'-6" square (Alt. B) are designated Type P. Larger standard structure bottoms are designated Type J. Risers are permitted for all structures. Round risers are designated Type A, square risers are designated Type B.
- Walls of circular structures (Alt. A) constructed in place may be of brick or reinforced concrete. Precast and rectangular structures (Alt. B) shall be constructed of reinforced concrete only.
- Wall thickness and reinforcement are for either reinforced cast-in-place or precast concrete units except that precast circular units may be furnished with walls in accordance with ASTM C478 (see modified wall thicknesses in Table 1).
- Top and bottom slab thickness and reinforcement are for precast and cast-in-place construction. All concrete shall be of Class II concrete, except use Class IV concrete when shown in the Plans, for special applications of structures located in extremely aggressive environments. Concrete as specified in ASTM C478 (4000 psi) may be used in lieu of Class II concrete for precast items manufactured in accordance with Specifications Section 449.
- All reinforcement shown is Grade 60 steel, deformed bar. Equivalent area Grade 40 steel or equivalent area smooth or deformed welded wire reinforcement in accordance with Specification Section 931 may be substituted according to Index No. 201, unless otherwise noted.
- Alt. A or Alt. B structure bottoms may be used in conjunction with curb inlet tops Types 1, 2, 3, 4, 5, 6, 9, and 10, and any manhole or junction box unless otherwise shown in the plans or other standard drawings. Alt. B structure bottoms may be used in conjunction with curb inlet Types 7 & 8, or any ditch bottom inlet unless otherwise shown in the plans or other standard drawings.
- Rectangular structures may be rotated as directed by the Engineer in order to facilitate connections between the structure walls and storm sewer pipes.
- Except when ACI hooks are specifically required, reinforcement in top and bottom slab shall be straight embedment.
- All reinforcement must have 2" minimum cover except for 3'-6" diameter precast circular units manufactured under ASTM C478, keyed construction otherwise shown. Additional bars used to restrain hole formers for precast structures with grouted pipe connections, may be left flush with the hole surface. Cut or bend reinforcement at pipe openings to maintain cover. Exposed ends of reinforcing at precast pipe openings and grouted joints must be removed to 1" below the concrete surface and sealed with a Type F epoxy in accordance with Specification Section 926. Horizontal steel in rectangular structures shall be lapped a minimum of 30 bar diameters or by standard hooks at corners.
- The corner fillets shown are necessary for rectangular structures used with circular risers and inlet throats and when used on skew with rectangular risers, inlets and inlet throats. Fillets will be required in the top slab of the Alt. A structure bottoms when used with the Alt. B risers. Each fillet shall be reinforced with two #5 bars.
- Inlet walls, throats, risers or manhole tops shall be secured to structures as shown on Index No. 201 (Sheet 3 of 5) Optional Construction Joints.
- Structures with depths over 14' below the mean high water table are to be checked for flotation by the designer of the drainage project.
- Units larger than specified standards may be substituted at the contractor's option when these units will not cause or increase the severity of utility conflicts. Such larger units shall be furnished at no additional cost to the Department. Larger Alt. A units cannot replace Alt. B units without approval of the Engineer. This note applies to this Index only.
- For manhole and junction box tops, for frames and covers, and, for supplementary details and notes see Index No. 201.
- Type J structure bottoms must have a minimum 6'-0" wall height when possible, for maintenance access.

C:\projects\standards\roadway\0200-s\0200-02.dgn 5/19/07 4:33:36 PM 6/24/2013

TABLE 3-MINIMUM STRUCTURE SIZES FOR SINGLE PIPE CONNECTION PER SIDE

PIPE SIZE	RECTANGULAR		ROUND	
	Side Dimension (L)		Diameter (D)	
	Single Pipe Per Side	Note Number	Single Pipe or $\theta=180^\circ$	2 to 4 Pipes $\theta=90^\circ$
18"	3'-6"		3'-6"	4'-0"
24"	3'-6"		3'-6"	5'-0"
30"	3'-6"/4'-0"	2	4'-0"	6'-0"
36"	4'-0"/5'-0"	3	5'-0"	7'-0"
42"	5'-0"		6'-0"	7'-0"
48"	6'-0"		6'-0"	8'-0"
54"	6'-0"		7'-0"	10'-0"
60"	7'-0"		7'-0"	10'-0"
66"	7'-0"/8'-0"	4	8'-0"	12'-0"
72"	8'-0"		8'-0"	12'-0"
78"	9'-0"		10'-0"	12'-0"
84"	9'-0"		12'-0"	N/A

TABLE 3 NOTES:

- For Round Structures sizes with variable angles between pipes and variable pipe sizes, refer to the FDOT Storm Drain Handbook.
- For 3'-6" Precast Square Structure Bottoms, 30" Pipes with similar invert elevations are not permitted in adjacent walls. Use 4'-0" Side Dimensions when 30" pipe openings are required on adjacent walls and the difference in flow lines is less than 3'-0".
- For 4'-0" Precast Square Structure Bottoms, 36" Pipes with similar invert elevations are not permitted in adjacent walls. Use 5'-0" Side Dimensions when 36" pipe openings are required on adjacent walls and the difference in flow lines is less than 3'-0".
- For 7'-0" Precast Square Structure Bottoms, 66" Pipes with similar invert elevations are not permitted in adjacent walls. Use 8'-0" Side Dimensions when 66" pipe openings are required on adjacent walls and the difference in flow lines is less than 4'-0".

TABLE 4-MINIMUM SIZES FOR MULTIPLE PARALLEL PIPE CONNECTIONS FOR RECTANGULAR STRUCTURE BOTTOMS

PIPE SIZE	PIPE SPACING (S)	MINIMUM WALL LENGTH (L) FOR NUMBER OF PARALLEL PIPES		
		2	3	4
18"	2'-10"	6'-0"	8'-6"	11'-0"
24"	3'-5"	6'-6"	10'-0"	13'-6"
30"	4'-3"	8'-0"	12'-6"	16'-6"
36"	5'-1"	9'-6"	14'-6"	19'-6"
42"	6'-0"	11'-0"	17'-0"	-
48"	6'-9"	12'-6"	19'-0"	-
54"	7'-8"	14'-0"	-	-
60"	8'-6"	15'-0"	-	-
66"	9'-0"	16'-6"	-	-
72"	10'-0"	18'-0"	-	-
78"	10'-9"	19'-0"	-	-
84"	11'-8"	20'-6"	-	-

TABLE 4 NOTES:

- Minimum wall lengths based on precast structures, using concrete pipe with maximum skew angles per Table 5.
- Wall lengths exceeding 20'-0" require special designs.

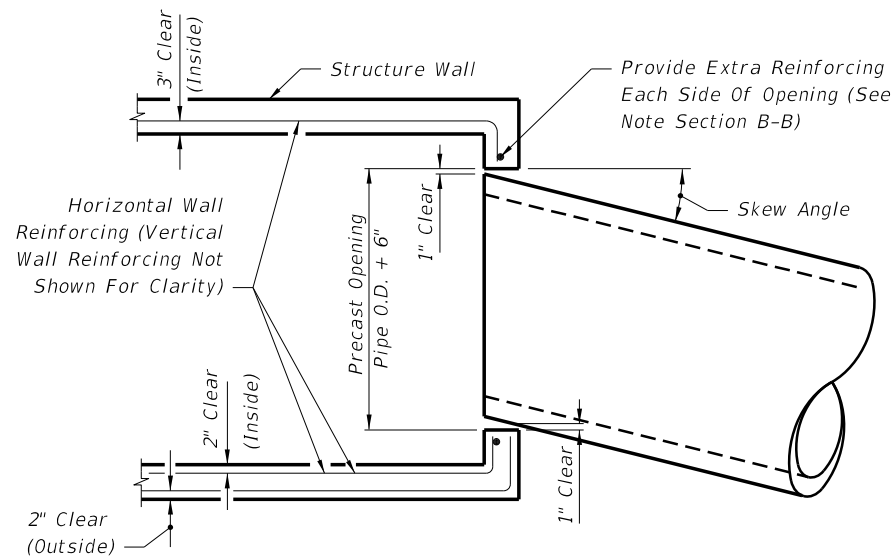

MAXIMUM PIPE SKEW FOR PRECAST ROUND OPENINGS PLAN VIEW

WALL THICKNESS	PIPE SIZE												
	18"	24"	30"	36"	42"	48"	54"	60"	66"	72"	78"	84"	
MAXIMUM SKEW ANGLE	8"	19°	17°	16°	16°	15°	14°	14°	13°	13°	13°	12°	12°

TABLE 5 NOTES:

These values are based on 2" clearance for precast structures. Larger skews are possible for Cast-In-Place Structures or elliptical pipe openings when approved by the Engineer.

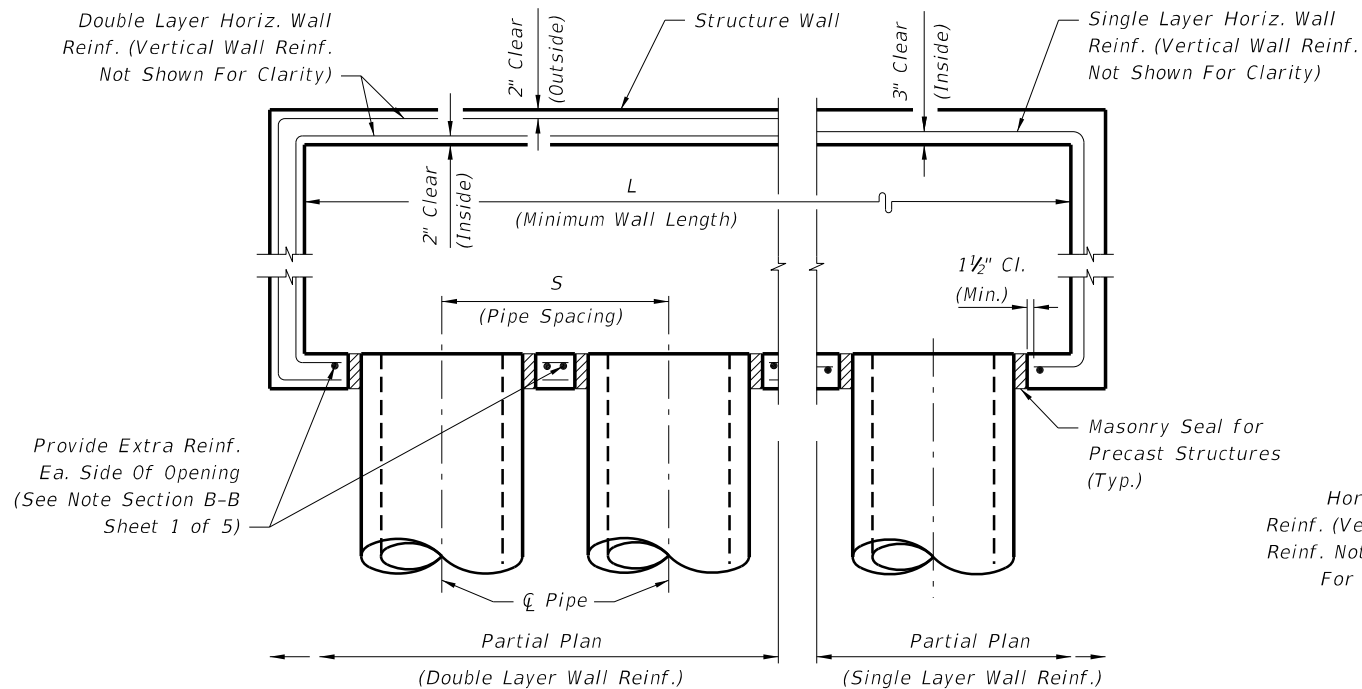

MULTIPLE PARALLEL PIPE CONNECTIONS DETAIL PLAN VIEW

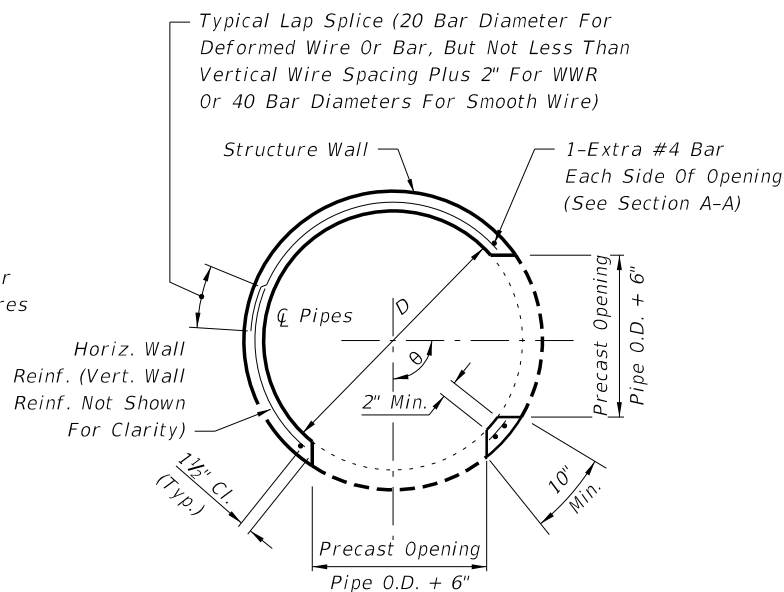

PRECAST ROUND STRUCTURES WITH MULTIPLE PIPE CONNECTIONS

STRUCTURE SIZES FOR PIPE CONNECTIONS

C:\p\projects\standards\roadway\02200-s\02200-03.dgn 4:33:38 PM smg70re 6/24/2013

SLAB DESIGNS - SQUARE AND RECTANGULAR STRUCTURES (TABLE 6)
(ALL SLABS 8" THICK EXCEPT AS NOTED - REINFORCING PARALLEL TO SHORT WAY AND LONG WAY)

SHORT-WAY		LONG-WAY	
SLAB DEPTH	SCHEDULE (Bars A)	SLAB DEPTH	SCHEDULE (Bars B)
SIZE: 3'-6" x UNLIMITED			
≥0.5' < 8'	B10	≥0.5' < 24'	B10
8' < 13'	B5.5	24'-40'	B5.5
13' < 31'	C6.5		
31'-40'	D7		
SIZE: 4' x UNLIMITED			
≥0.5' < 7'	B5.5	≥0.5' < 15'	B10
7' < 19'	C6.5	15' < 29'	B5.5
19' < 31'	D7	29'-40'	C6.5
31'-40'	E5		
SIZE: 5' x 5'			
≥0.5' < 3'	C6.5	≥0.5' < 3'	C6.5
3' < 7'	B5.5	3' < 13'	C6.5
7' < 22'	C6.5	13' < 22'	D7
22' < 29'	D7	22' < 29'	D4.5
29'-40'	E5	29'-40'	E5
SIZE: 5' x 6'			
≥0.5' < 12'	C6.5	≥0.5' < 3'	C6.5
12' < 26'	D7	3' < 9'	B5.5
26'-40'	E5	9' < 23'	C3.5
		23' < 35'	D4.5
		35'-40'	E5
SIZE: 5' x 7'			
≥0.5' < 10'	C6.5	≥0.5' < 10'	B5.5
10' < 20'	D7	10' < 31'	C3.5
20' < 34'	E5	31'-40'	D4.5
34'-40'	F5		
SIZE: 5' x 8'			
≥0.5' < 7'	C6.5	≥0.5' < 8'	B10
7' < 13'	D7	8' < 17'	B5.5
13' < 24'	E5	17' < 25'	C6.5
24'-40'	F5	25'-40'	C3.5
SIZE: 5' x 9'			
≥0.5' < 8'	C6.5	≥0.5' < 14'	B10
8' < 14'	D7	14' < 24'	B5.5
14' < 25'	E5	24' < 34'	C6.5
25'-40'	F5	34'-40'	C3.5
SIZE: 5' x UNLIMITED			
≥0.5' < 8'	C6.5	≥0.5' < 14'	B10
8' < 14'	D7	14' < 24'	B5.5
14' < 25'	E5	24' < 34'	C6.5
25'-40'	F5	34'-40'	C3.5

SHORT-WAY		LONG-WAY	
SLAB DEPTH	SCHEDULE (Bars A)	SLAB DEPTH	SCHEDULE (Bars B)
SIZE: 6' x 6'			
≥0.5' < 13'	C6.5	≥0.5' < 10'	C3.5
13' < 23'	D7	10' < 18'	D4.5
23'-40'	E5	18' < 27'	E5
		27' < 33'	E3
		33'-40'	F5
SIZE: 6' x 7'			
≥0.5' < 8'	C6.5	≥0.5' < 8'	C6.5
8' < 16'	D7	8' < 12'	C3.5
16' < 28'	E5	12' < 21'	D4.5
28'-40'	F5	21' < 28'	E5
		28' < 35'	E3
		35'-40'	F5
SIZE: 6' x 8'			
≥0.5' < 6'	C6.5	≥0.5' < 6'	B5.5
6' < 13'	D7	6' < 11'	C6.5
13' < 22'	E5	11' < 17'	C3.5
22' < 35'	F5	17' < 22'	D4.5
35'-40'	G5	22' < 32'	E5
		32'-40'	E3
SIZE: 6' x 9'			
≥0.5' < 8'	D7	≥0.5' < 8'	B5.5
8' < 14'	E5	8' < 14'	C6.5
14' < 24'	F5	14' < 21'	C3.5
24'-34'	G5	21' < 25'	D4.5
		25'-34'	E5
SIZE: 6' x UNLIMITED			
≥0.5' < 8'	D7	≥0.5' < 8'	B5.5
8' < 14'	E5	8' < 14'	C6.5
14' < 24'	F5	14' < 21'	C3.5
24'-34'	G5	21' < 25'	D4.5
		25'-34'	E5
SIZE: 7' x 7'			
≥0.5' < 8'	C6.5	≥0.5' < 4'	C6.5
8' < 15'	D7	4' < 7'	C3.5
15' < 26'	E5	7' < 11'	D4.5
26'-40'	F5	11' < 22'	E3
		22' < 32'	F3.5
		32'-40'	G3.5
SIZE: 7' x 8'			
≥0.5' < 5'	C6.5	≥0.5' < 5'	C6.5
5' < 11'	D7	5' < 8'	C3.5
11' < 19'	E5	8' < 13'	D4.5
19' < 30'	F5	13' < 22'	E3
30'-40'	G5	22' < 30'	F3.5
		30'-40'	G3.5
SIZE: 7' x 9'			
≥0.5' < 9'	D7	≥0.5' < 7'	C6.5
9' < 15'	E5	7' < 10'	C3.5
15' < 25'	F5	10' < 14'	D4.5
25' - 34'	G5	14' < 21'	E5
		21' < 29'	F5
		29'-34'	F3.5

SHORT-WAY		LONG-WAY	
SLAB DEPTH	SCHEDULE (Bars A)	SLAB DEPTH	SCHEDULE (Bars B)
SIZE: 8' x 8'			
≥0.5' < 10'	D7	≥0.5' < 9'	D4.5
10' < 19'	E5	9' < 13'	E5
19'-30'	F5	13' < 18'	F5
		18' < 23'	F3.5
		23'-30'	G3.5
SIZE: 8' x 9'			
≥0.5' < 8'	D7	≥0.5' < 7'	D7
8' < 14'	E5	7' < 9'	D4.5
14' < 23'	F5	9' < 15'	E3
23'-31'	G3.5	15' < 20'	F5
		20' < 23'	F3.5
		23'-31'	G3.5
SIZE: 9' x 9'			
≥0.5' < 8'	D7	≥0.5' < 7'	D4
8' < 14'	E5	7' < 10'	E5
14' < 22'	F5	10' < 17'	F3.5
		17' < 22'	G3.5
SIZE: 9'x9'x10" SLAB THICKNESS			
22' < 36'	F5	22' < 31'	F3.5
36'-40'	G5	31'-40'	G3.5
SIZE: 10'x10'x10" SLAB THICKNESS			
≥0.5' < 7'	C6.5	0.5' < 6'	C6.5
7' < 10'	D7	6' < 9'	D4.5
10' < 18'	E5	9' < 15'	E5
18' < 27'	F5	15' < 22'	F5
27'-32'	G5	22'-32'	G3.5
SIZE: 12'x12'x12" SLAB THICKNESS			
≥0.5' < 10'	D7	≥0.5' < 8'	D7
10' < 16'	E5	8' < 14'	E5
16' < 25'	F5	14' < 22'	F5
25'-35'	G5	22' < 30'	G5
		30'-35'	H4

SLAB AND WALL DESIGN TABLE NOTES

- Size is the inside dimension(s) of a structure.
- Slab reinforcement is appropriate for top, intermediate, and bottom slabs.
- Bottom Slabs for precast 3'-6" x 3'-6" rectangular structures at 15' depth or less, may be 6" thick.
- Slab depth is measured from finished grade to top of slab.
- Wall depth is measured to the top of the bottom slab for boxes and to the top of the intermediate slab for risers.
- Wall height is the distance between top of lower slab to bottom of upper slab. Maximum wall height is 12' for wall lengths exceeding 5', or 10' for wall lengths exceeding 12'.
- Wall lengths exceeding 6'-0" require two layers of reinforcing (See Table 8) with 2" of cover from the horizontal bars to the inside and outside faces for each layer.
- Wall lengths exceeding the dimensions or depths shown in Table 8, or 12'-0" diameter require a special design.
- Wall thickness and reinforcing for rectangular structures is the same for both long and short sides.
- Reinforcing schedules with larger areas of steel may be substituted for schedules with smaller bar or wire spacing, except that Schedule B10 may not be substituted for Schedule A6. See Index 201, Sheet 4 for allowable bar spacing adjustments when larger areas of reinforcing are substituted.

SLAB DESIGNS - ROUND STRUCTURES (TABLE 7)

SLAB DEPTH	SLAB THICKNESS	REINF. (2-WAY) SCHEDULE
SIZE: 3'-6" DIAMETER		
2'-15'	6" Precast	C6.5
0.5' < 30'	8"	A6
30'-40'	8"	B5.5
SIZE: 4'-0" DIAMETER		
≥0.5' < 19'	8"	A6
19' < 30'	8"	B5.5
30'-40'	8"	C6.5
SIZE: 5'-0" DIAMETER		
≥0.5' < 15'	8"	B5.5
15' < 26'	8"	C6.5
26' < 35'	8"	D7
35'-40'	8"	D4.5
SIZE: 6'-0" DIAMETER		
≥0.5' < 9'	8"	B5.5
9' < 15'	8"	C6.5
15' < 22'	8"	C3.5
22' < 30'	8"	D4.5
30'-40'	8"	E5
SIZE: 7'-0" DIAMETER		
≥0.5' < 8'	8"	C3.5
8' < 16'	8"	D4.5
16' < 23'	8"	E5
23' < 27'	8"	E3
27'-40'	8"	F3.5
SIZE: 8'-0" DIAMETER		
≥0.5' < 10'	8"	D4.5
10' < 16'	8"	E5
16' < 19'	8"	E3
19' < 29'	8"	F3.5
29'-40'	10"	F5
SIZE: 10'-0" DIAMETER		
≥0.5' < 12'	10"	D4.5
12' < 20'	10"	E5
20' < 28'	10"	F5
28'-40'	10"	G3.5
SIZE: 12'-0" DIAMETER		
≥0.5' < 8'	10"	D4.5
8' < 13'	10"	E5
13' < 18'	10"	F5
18' < 26'	10"	G3.5
26'-40'	12"	G3.5

C:\projects\standards\roadway\02200-s-00200-04.dgn 5/19/2014 4:33:40 PM smg70re 6/24/2013

WALL DESIGNS - RECTANGULAR STRUCTURES (TABLE 8)

VERTICAL REINFORCING		HORIZONTAL REINFORCING		WALL THICKNESS
WALL DEPTH	SCHEDULE	WALL DEPTH	SCHEDULE	
SIZE: 3'-6" & RISERS				
≥1.17' - 40'	A12	≥1.17' < 10'	B10	6"/8"
		10' < 18'	B5.5	6"/8"
		18' < 29'	C6.5	6"/8"
		29' - 40'	C3.5	6"/8"
SIZE: 4'-0"				
≥1.17' - 40'	A12	≥1.17' < 6'	B10	6"/8"
		6' < 10'	B5.5	6"/8"
		10' < 20'	C6.5	6"/8"
		20' < 28'	C3.5	6"/8"
		28' - 40'	D4.5	6"/8"
SIZE: 5'-0"				
≥1.17' - 40'	A12	≥1.17' < 5'	B5.5	6"/8"
		5' < 9'	C6.5	6"/8"
		9' < 15'	C3.5	6"/8"
		15' < 22'	D4.5	6"/8"
		22' - 40'	E3	8"
SIZE: 6'-0"				
≥1.17' < 26'	A12	≥1.17' < 9'	C3.5	6"/8"
		9' < 15'	D4.5	6"/8"
		15' < 26'	E3	8"
	Inside/Outside		Inside/Outside	
26' - 40'	A12 A12	26' - 40'	D7 D7	8"
SIZE: 7'-0"				
	Inside/Outside		Inside/Outside	
≥1.17' < 25'	A12 A12	≥1.17' < 7'	B10 B10	8"
26' - 40'	B10 B10	7' < 10'	B5.5 B5.5	8"
		10' < 20'	C6.5 C6.5	8"
		20' < 30'	D7 D7	8"
		30' - 40'	E5 E5	8"
SIZE: 8'-0"				
	Inside/Outside		Inside/Outside	
≥1.17' < 20'	A12 A12	≥1.17' < 6'	B5.5 B5.5	8"
20' - 40'	C6.5 C6.5	6' < 13'	C6.5 C6.5	8"
		13' < 22'	D7 D7	8"
		22' < 31'	E5 E5	8"
		31' - 40'	F5 F5	8"
SIZE: 9'-0"				
	Inside/Outside		Inside/Outside	
≥1.17' < 12'	A12 A12	≥1.17' < 8'	C6.5 C6.5	8"
12' < 28'	C6.5 C6.5	8' < 15'	D7 D7	8"
28' - 40'	D7 D7	15' < 23'	E5 E5	8"
		23' - 40'	F5 F5	8"
SIZE: 10'-0"				
	Inside/Outside		Inside/Outside	
≥1.17' < 10'	B10 B10	≥1.17' < 10'	D7 D7	8"
10' < 21'	C6.5 C6.5	10' < 17'	E5 E5	8"
21' < 26'	D7 D7	17' < 26'	F5 F5	8"
26' - 40'	C6.5 C6.5	26' - 40'	F5 F5	10"

VERTICAL REINFORCING		HORIZONTAL REINFORCING		WALL THICKNESS
WALL DEPTH	SCHEDULE	WALL DEPTH	SCHEDULE	
SIZE: 10'-0" (Precast Only)				
	Inside/Outside		Inside/Outside	
26' - 40'	D7 D7	26' - 40'	F5 F5	9"
SIZE: 12'-0"				
	Inside/Outside		Inside/Outside	
≥1.17' < 14'	B10 B10	≥1.17' < 10'	C6.5 C6.5	10"
14' < 25'	C6.5 C6.5	10' < 17'	D7 D7	10"
25' - 40'	D7 D7	17' < 24'	E5 E5	10"
		24' - 40'	F5 F5	10"
SIZE: 12'-0" (Precast Only)				
	Inside/Outside		Inside/Outside	
≥1.17' < 12'	B10 B10	≥1.17' < 10'	D7 D7	9"
12' < 24'	C6.5 C6.5	10' < 17'	D4.5 D4.5	9"
24' - 40'	D7 D7	17' < 23'	E5 E5	9"
		23' < 32'	F5 F5	9"
		32' - 40'	G5 G5	9"
SIZE: 16'-0"				
	Inside/Outside		Inside/Outside	
≥1.17' < 11'	C6.5 C6.5	≥1.17' < 13'	D7 D7	10"
11' < 20'	D7 D7	13' < 20'	E5 E5	10"
20' < 28'	E5 E5	20' < 28'	F5 F5	10"
28' - 40'	F5 F5	28' - 40'	G5 G5	10"
SIZE: 16'-0" (Precast Only)				
	Inside/Outside		Inside/Outside	
≥1.17' < 10'	C6.5 C6.5	≥1.17' < 9'	D7 D7	9"
10' < 18'	D7 D7	9' < 13'	D4.5 D4.5	9"
18' < 25'	E5 E5	13' < 19'	E5 E5	9"
25' - 35'	F5 F5	19' < 27'	F5 F5	9"
		27' - 35'	G5 G5	9"
SIZE: 20'-0"				
	Inside/Outside		Inside/Outside	
≥1.17' < 10'	C6.5 C6.5	≥1.17' < 8'	D7 D7	10"
10' < 17'	D7 D7	8' < 12'	E5 E5	10"
17' - 30'	E5 E5	12' < 20'	F5 F5	10"
		20' - 30'	G5 G5	10"
SIZE: 20'-0" (Precast Only)				
	Inside/Outside		Inside/Outside	
≥1.17' < 8'	C6.5 C6.5	≥1.17' < 8'	D4.5 D4.5	9"
8' < 13'	D7 D7	8' < 12'	E5 E5	9"
13' - 25'	E5 E5	12' < 19'	F5 F5	9"
		19' - 25'	G5 G5	9"

REINFORCING SCHEDULE				
SCHEDULE	GRADE 60 BARS OR 65 KSI & 70 KSI WELDED WIRE REINFORCING			
	GRADE 60 AREA (in. ² /ft.)	MAXIMUM SPACING		
		GR 60 BARS (in.)	65 KSI (in.)	70 KSI (in.)
A12	0.20	12	8	8
A6	0.20	6	5	4½
B10	0.24	10	8	7½
B5.5	0.24	5½	5	4
C6.5	0.37	6½	6	5
C3.5	0.37	3½	3	2½
D7	0.53	7	6	5
D4.5	0.53	4½	4	3½
E5	0.73	5	4	4
E3	0.73	3	3	3
F5	1.06	5	4	4
F3.5	1.06	3½	3	3
G5	1.45	5	4	4
G.3.5	1.45	3½	3	3
H4	1.75	4	3	3

*Equivalent Area Welded Wire Reinforcing may be substituted in accordance with Index No. 201, Sheet 4.

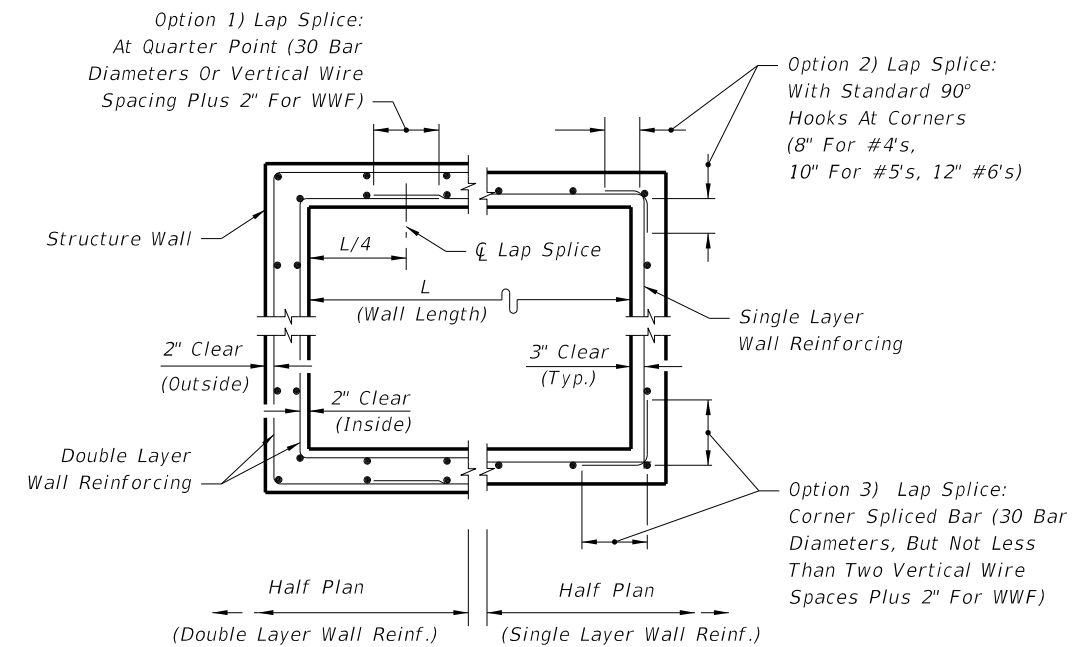

WALL REINFORCING SPLICE DETAILS (ALTERNATE B)

C:\projects\standards\roadway\00200-s-00200-05.dgn 4:33:42 PM smg70re 6/24/2013