

C:\projects\standards\roadway\11000-s\11871-1 of 2.dgn
rd960rh
3:59:46 PM
7/25/2012

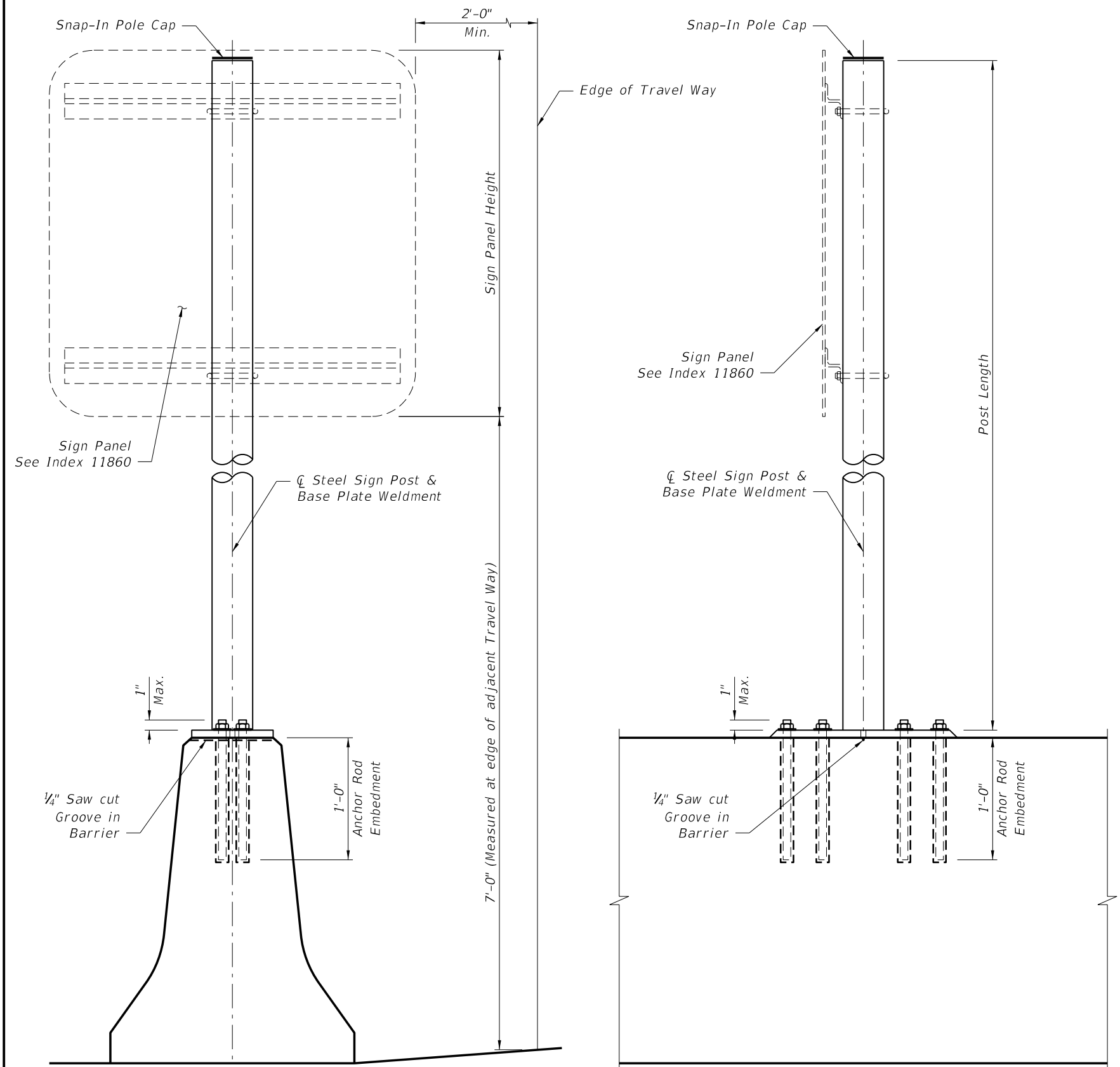

ELEVATION
 (Index 410 Standard "Full Wall" Median Barrier shown; others similar)

NOTES:

DESIGN SPECIFICATIONS:
 AASHTO Standard Specifications for Structural Supports for Highway Signs, Luminaires and Traffic Signals as modified by the FDOT Structures Manual.

WIND SPEEDS:
 See Index 11860, "Wind speeds by County" note.

GEOMETRY:
 Maximum Sign Panel Height is 6'-0".
 Edges of Sign Panels must be a minimum of 2'-0" clear from edge of adjacent Travel Way.

APPLICABILITY:
 Work this Index in conjunction with Index No 11860.

SHOP DRAWINGS:
 Shop drawings are not required.

PAYMENT:
 Include payment for sign support in the cost of the single post sign assembly.

MATERIALS:
 Sign Post: ASTM A53 Grade B, NPS Schedule 40 Steel Pipe, sized per Table 1. Maximum post length is 10'-0".
 Snap-In Pole Cap: Provide UV and weather-resistant glass-filled polyester cap.
 Steel Plates: ASTM A572 Grade 50 or A709 Grade 50.

Welding: Weld in accordance with American Welding Society Structural Welding Code (Steel), ANSI/DWS D1.1 (current edition). Required weld material is E70XX. Nondestructive testing is not required.

Coatings: Hot dip galvanize all steel, including fasteners, in accordance with Section 962. Galvanize Weldment after fabrication.

INSTALLATION:
Placement: For installations on permanent Median Barriers, locate Sign Support a minimum of 5'-0" away from open joints or transitions. For installations on Temporary Barriers, locate Sign Support at the midpoint along the length of a single segment. In all cases, shift locations as needed to avoid conflicts with reinforcement.
Bearing Surface: Surface of the railing must be structurally sound and free of cracks and spalls. Base plate must be flush with the concrete surface; grind any high spots to obtain a flat, smooth surface.
Saw Cut: For permanent installations only, saw cut a 1/4" deep groove transversely across the top of railing at the centerline of base plate vent hole location.
Anchor Rods: Use ASTM F1554 Grade 36, fully threaded rods with A563 or A194 single self-locking hex nuts and F436 washers. Size anchor rods per Table 2.

Adhesive Bonding Material: Install anchor rods using Type HSHV Adhesive Bonding Material System in accordance with Specification Sections 416 & 937. For temporary sign support installations, the use of a metal detector specifically designed for locating steel in concrete is not required to locate existing reinforcement as stated within Specification Section 416-4. For temporary sign support installations, Specification Section 416-6 is not required. For permanent sign support installations, Specification Section 416-6 applies with the exception of the following: Perform field test on only one anchor per sign support location.

Removal of Signs: Cut anchor rods flush with top of railing and coat surface with Type F-1 epoxy. Minimum thickness of epoxy is 1/16" extending 2" beyond the location of steel.

R2013-01

Wind Speed (MPH)	Max. Sign Area (SF)	Post Ø (NPS)
70 - All Temporary Signs	< 20	3.0"
110 & 130	< 13.5	3.0"
	13.5 < Sign < 20	3.5"
150	< 13.5	3.5"
	13.5 < Sign < 20	4.0"

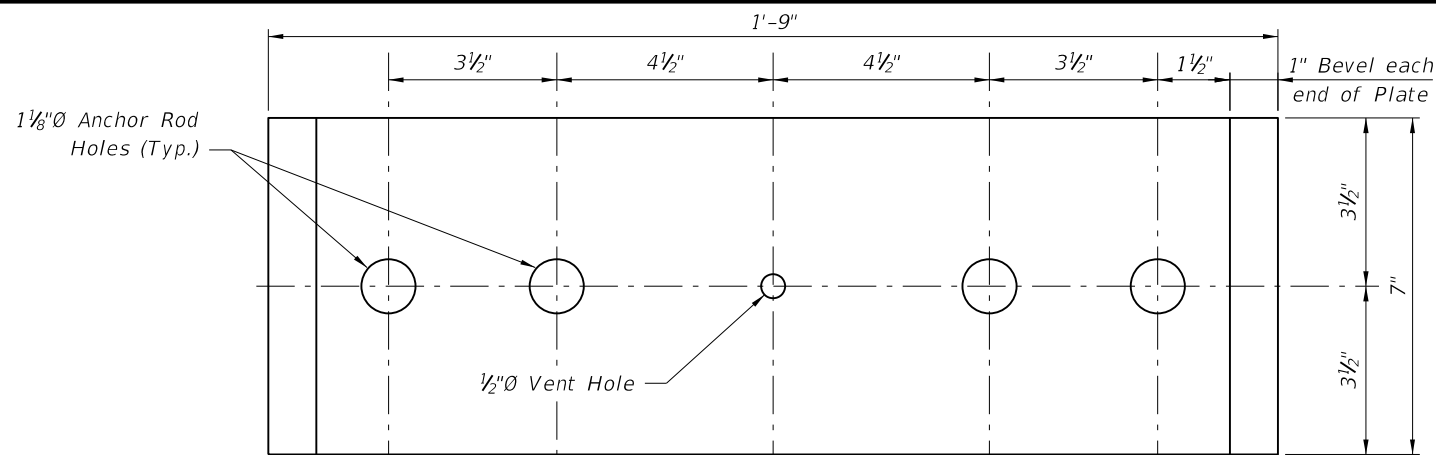

PLAN
ELEVATION
BASE PLATE TYPE A
(Linear Anchor Rod Pattern)

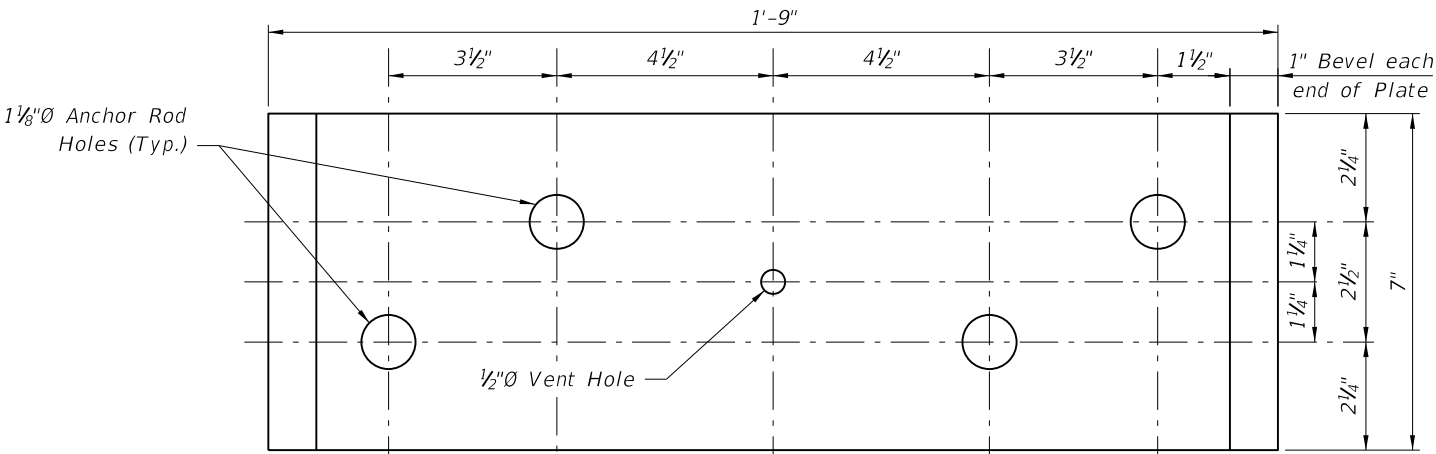

PLAN
ELEVATION
BASE PLATE TYPE B
(Staggered Anchor Rod Pattern)

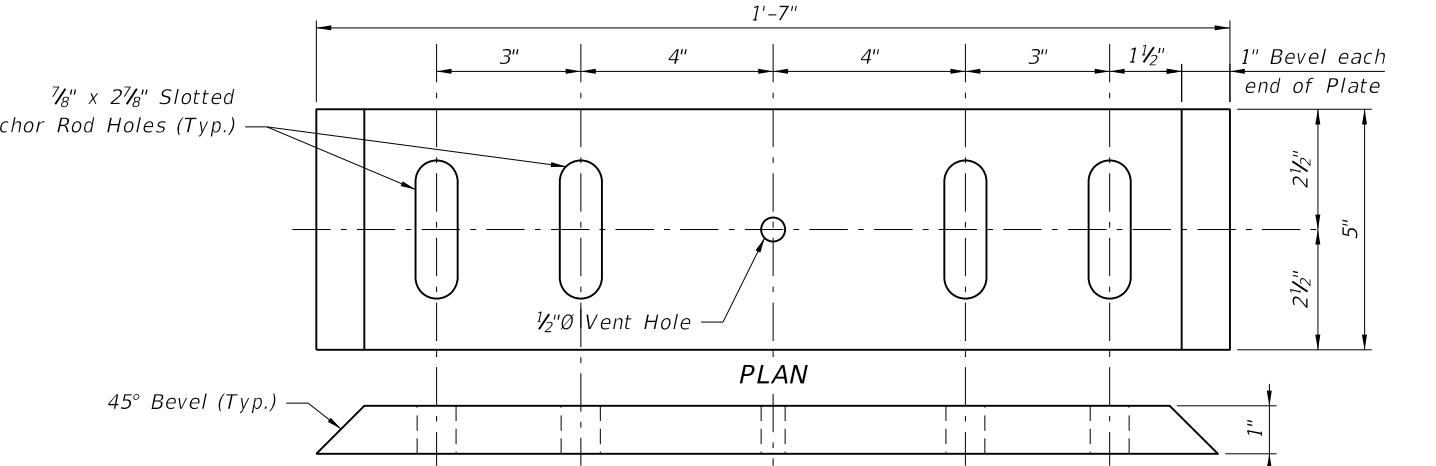

PLAN
ELEVATION
BASE PLATE TYPE C ***

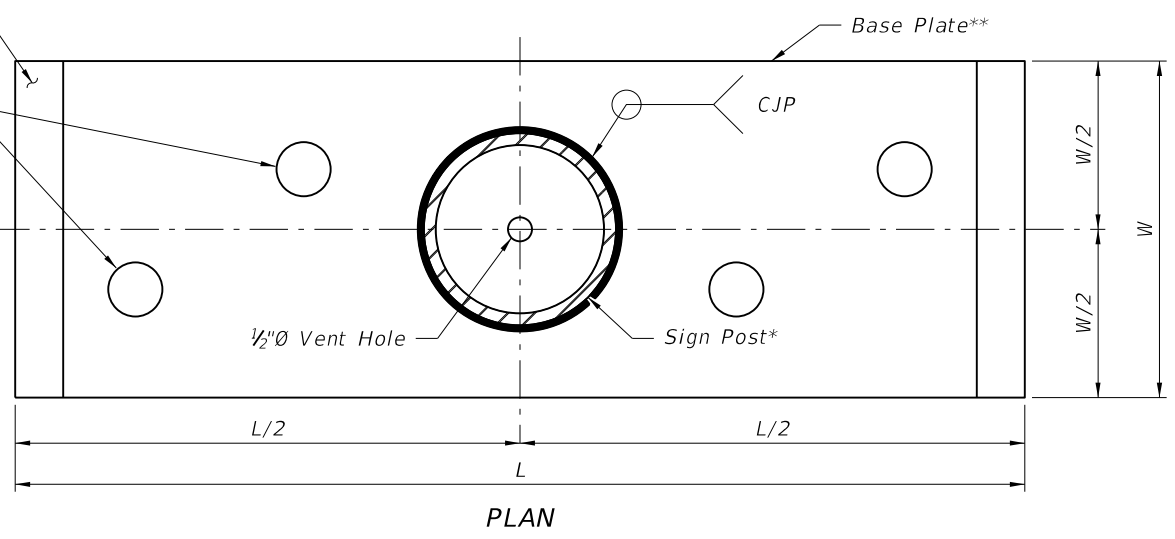
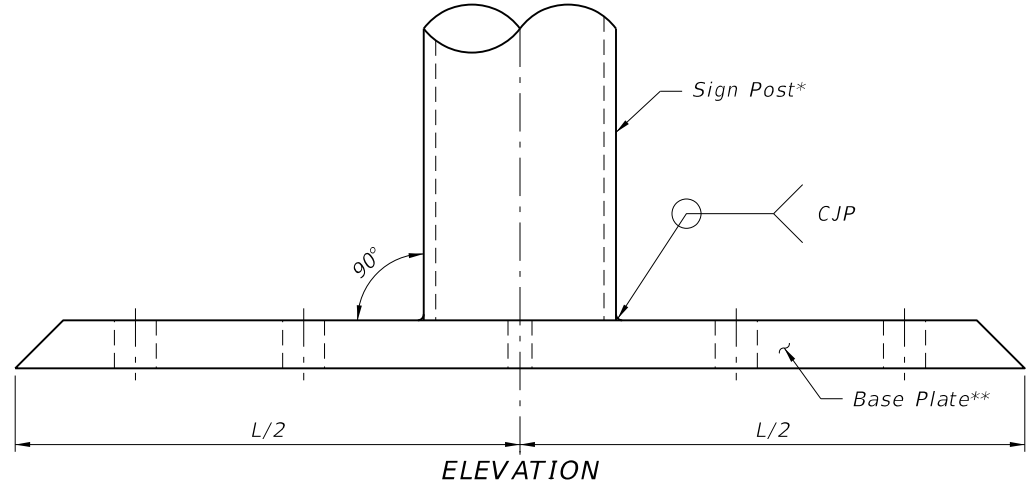

SIGN SUPPORT WELDMENT DETAIL
(Staggered Anchor Rod Pattern shown; Linear Anchor Rod Pattern similar)

* See Table 1, Sheet 1.
** See Table 2, this Sheet.

Index No.	Type/Application	Base Plate Type	Anchor Rod Ø
410	Full Wall	B	1"
410	Cantilever or L-Wall	A	
420 & 425	When Clear Space between Dual Bridge Traffic Railing is ≤ 4'-0"	A	
421	All Applications	A	
All listed above Plus 414 & 415	Temporary Signs	C ***	3/4" ***

*** Place anchor rods in a staggered or linear pattern as necessary to avoid reinforcing. Use a staggered pattern for all temporary barriers.

C:\projects\standards\roadway\11000-s\11871-2of2.dgn
r0960rh
3-30-04 PM
7/25/2012

LAST REVISION	DESCRIPTION:
07/01/12	