

ORIENTATION VIEW

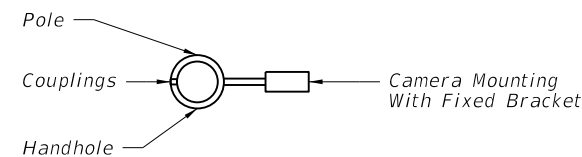

ORIENTATION VIEW

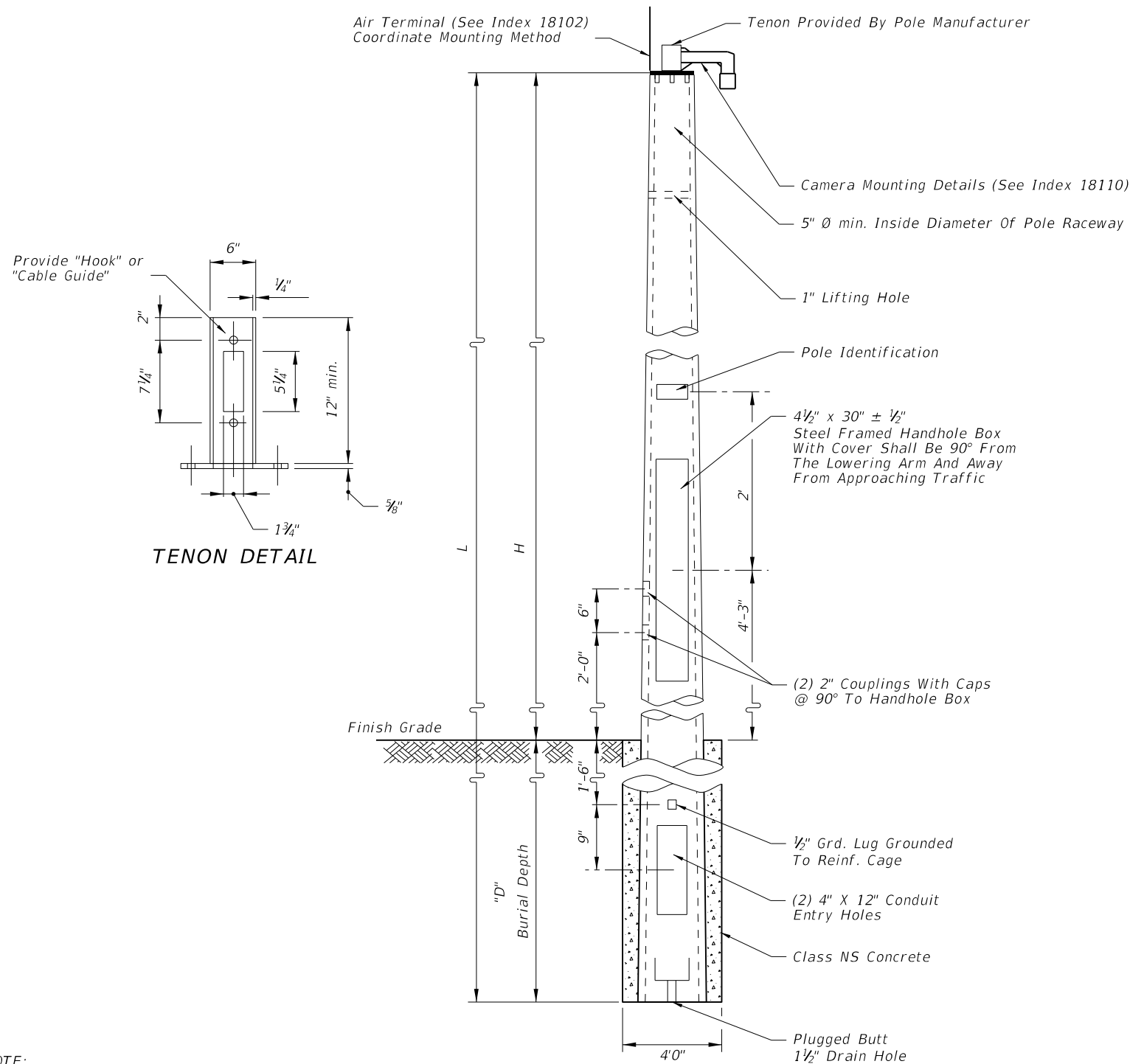

WITH LOWERING DEVICE

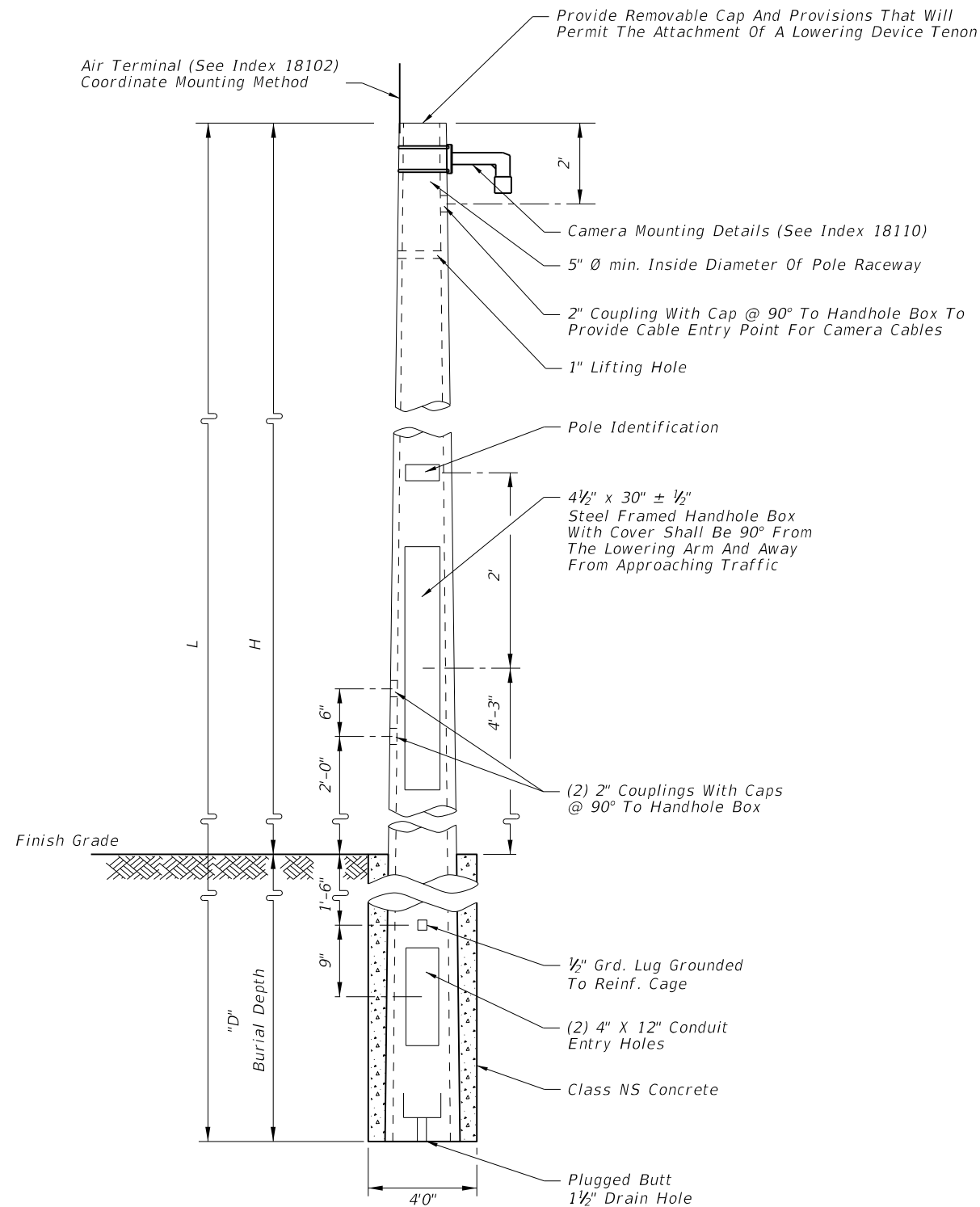

WITHOUT LOWERING DEVICE

NOTE:  
Coordinate all lowering device hardware requirements (including Tenon, Tenon mounting plates, parking stand, etc.) with lowering device manufacturer.

LAST REVISION	DESCRIPTION:
01/01/11	



FDOT DESIGN STANDARDS  
2013

CONCRETE CCTV POLE

INDEX NO.	SHEET NO.
18113	1

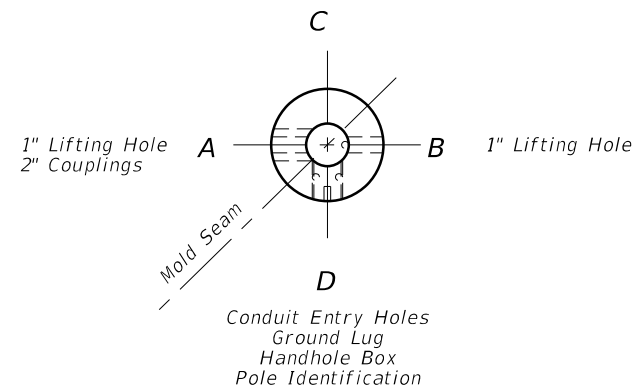

TOP VIEW

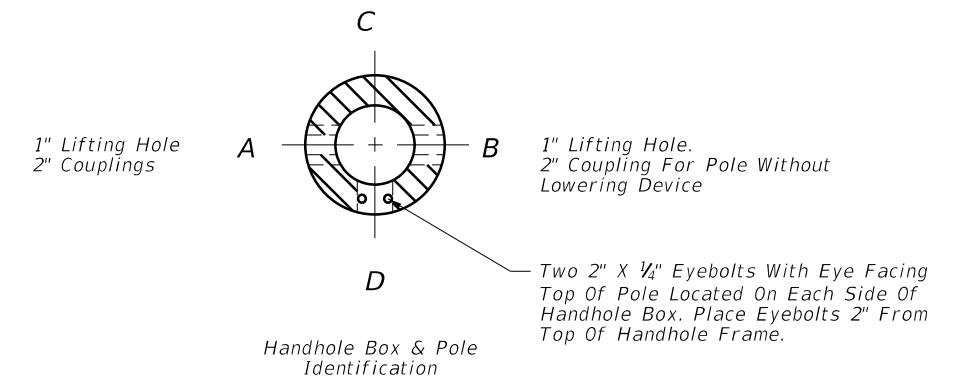

SECTIONAL VIEW THROUGH HAND HOLE BOX

**GENERAL NOTES:**

Design according to FDOT Structures Manual current edition.

Manufacturers seeking approval for inclusion on the Qualified Products List must submit a QPL Product Evaluation Application along with design documentation and drawings showing the product meets all specified requirements of this Standard. Provide documentation that certifies and demonstrates that the pole is designed to accommodate and be compatible with a lowering device listed on the Approved Product List.

Place prestressing symmetrically about both axis.

Use Class V Special Concrete or Class VI Concrete with 4 ksi minimum strength at transfer.

Use ASTM A615 Grade 60 reinforcing steel. Provide a minimum of non-prestressed reinforcement equal to 0.33% of the concrete area.

Use ASTM A416 Grade 270 stress relieved or low-lax prestressing strands.

One turn required for spiral splices and two turns required at the top and bottom of poles. Manufacture spirals from cold-drawn ASTM A82 steel wire.

Identify poles as to manufacturer, pole length, certification number and QPL qualification number by inset numerals 1" in height inscribed on the same face of the pole as the handhole and ground wire.

Provide a Class 3 surface finish.

Provide a 1" minimum cover.

Foundation design based upon the following soil criteria:

- Classification = Cohesionless (Fine Sand)
- Friction Angle = 30 Degrees (30°)
- Unit Weight = 50 lbs./cu. Ft. (assumed saturated)

Only in cases where the Designer considers the soil types at the specific site location to be of lesser strength properties should an analysis be required. Auger borings, SPT borings or CPT soundings may be utilized as needed to verify the assumed soil properties, and at relatively uniform sites, a single boring or sounding may cover several foundations. Furthermore, borings in the area that were performed for other purposes may be used to confirm the assumed soil properties.

**SPECIFICATIONS:**

Pole Top:	10 1/2" Diameter minimum
Pole Taper:	0.2 in/ft nominal
Defl Spec:	1" max. In 40 mph Wind (3 second gust)
Max. Camera EPA:	5.60 sq. ft Total
Max. Camera Wgt:	240 lbs Total

**LOWERING DEVICE INSTALLATION NOTES:**

Design tenon dimensions to facilitate lowering device component installation. Locate slots parallel to the pole centerline for mounting the lowering device. Bolt a tenon to the pole top with mounting holes and slot as required for the mounting of the lowering device.

Place the lowering cable that moves within the pole in an interior conduit to prevent it from tangling or interfering with any electrical wire that is in the pole. Ensure that any electrical wire within the pole is routed securely and free from slack.

Mount lowering arm perpendicular to the roadway or as shown in the plans. Position CCTV pole so that the camera can be safely lowered without requiring lane closures.

L (ft)	H (ft)	D (ft)
63	50	13
69	55	14
75	60	15
80	65	15
86	70	16

C:\p\projects\standards\18113-02.dgn 6/28/2012 12:44:15 PM rd960/h