

ORIENTATION VIEW

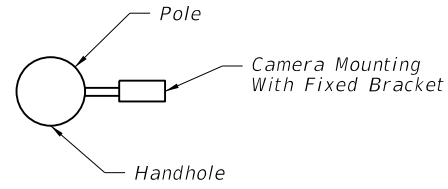

ORIENTATION VIEW

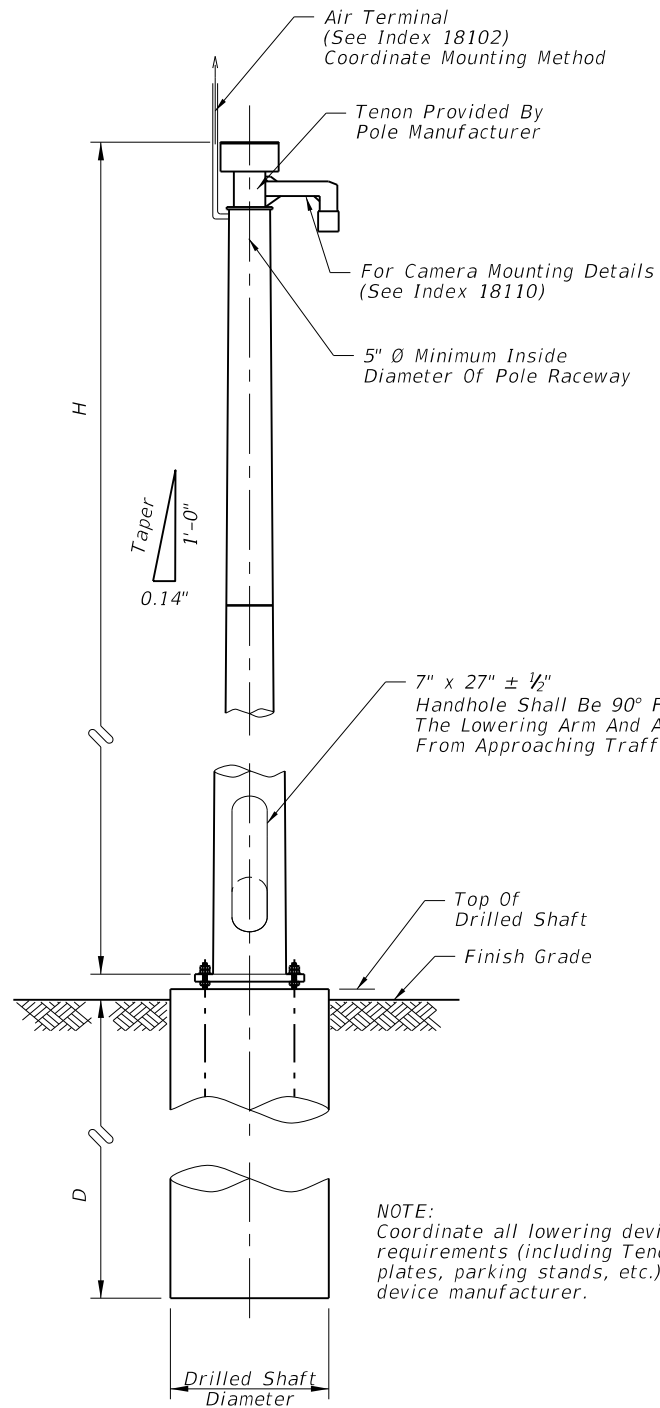

WITH LOWERING DEVICE

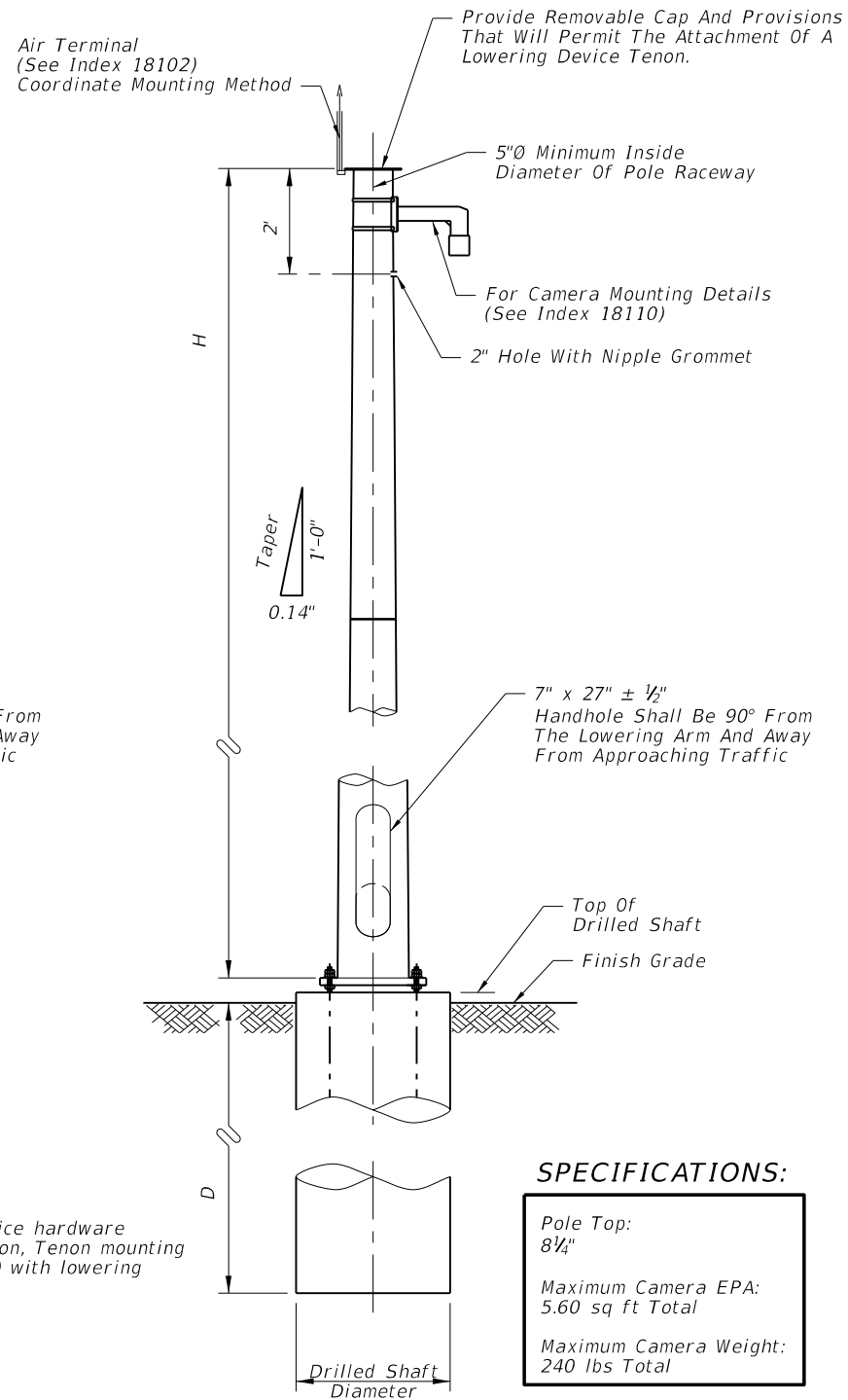

WITHOUT LOWERING DEVICE

**SPECIFICATIONS:**

Pole Top:  
8 1/4"

Maximum Camera EPA:  
5.60 sq ft Total

Maximum Camera Weight:  
240 lbs Total

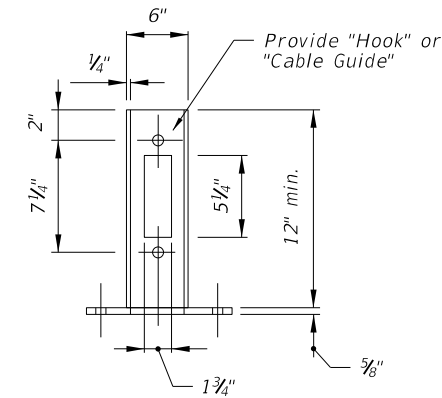

TENON DETAIL

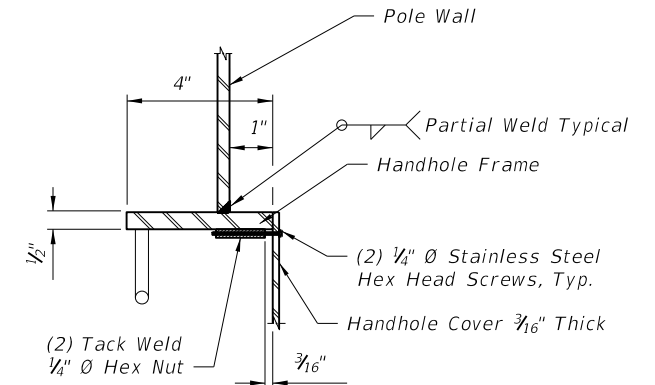

SECTION A-A

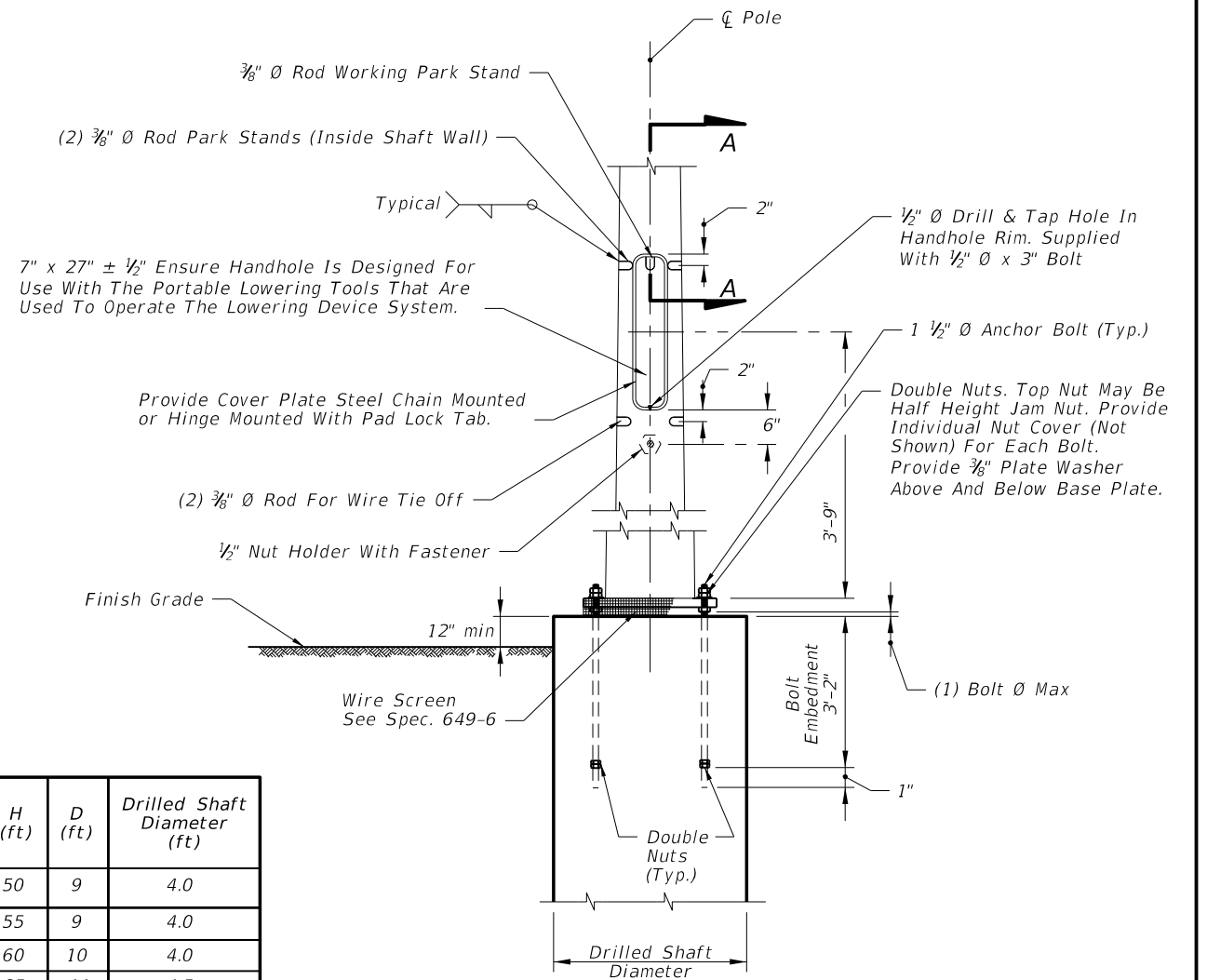

FOUNDATION AND HANDHOLE DETAIL

H (ft)	D (ft)	Drilled Shaft Diameter (ft)
50	9	4.0
55	9	4.0
60	10	4.0
65	11	4.5
70	11	4.5

C:\projects\standards\18111-01.dgn 6/28/2012 12:43:40 PM rd960rh

**DESIGN NOTES:**

Design according to FDOT Structures Manual.

Maximum 1" deflection in 40mph wind (3 second gust).

Perform all welding in accordance with the American Welding Society Structural Welding Code (Steel) ANSI/AWS D1.1 (current edition).

**Foundation materials:**

Reinforcing Steel: ASTM A615 Grade 60

Concrete: Class IV (Drilled Shaft) with a minimum 4,000 psi compressive strength at 28 days for all environment classifications.

Anchor Bolts: ASTM F1554 Grade 55 with ASTM A563 Grade A heavy-hex nuts.  
ASTM F436 Type 1 washers.  
ASTM F2329 galvanization.

Foundation design based upon the following soil criteria:

- Classification = Cohesionless (Fine Sand)
- Friction Angle = 30 Degrees (30°)
- Unit Weight = 50 lbs./cu. Ft. (assumed saturated)

Only in cases where the Designer considers the soil types at the specific site location to be of lesser strength properties should an analysis be required.

Auger borings, SPT borings or CPT soundings may be utilized as needed to verify the assumed soil properties, and at relatively uniform sites, a single boring or sounding may cover several foundations. Furthermore, borings in the area that were performed for other purposes may be used to confirm the assumed soil properties.

**INSTALLATION NOTES:**

Cable Supports: Electrical Cable Guides and Eyebolts.

Locate top and bottom electrical guides within the pole aligned with each other.

Position one cable guide 2" below the handhole.

Position other cable guide 1" directly below the top of the tenon.

Position eyebolt 2-3/4" below the top of the handhole.

Install pole plumb.

**Lowering Device Installation Notes:**

Design tenon dimensions to facilitate lowering device component installation. Locate slots parallel to the pole centerline for mounting the lowering device. Bolt a tenon to the pole top with mounting holes and slot as required for the mounting of the lowering device.

Place the lowering cable that moves within the pole in an interior conduit to prevent it from tangling or interfering with any electrical wire that is in the pole. Ensure that any electrical wire within the pole is routed securely and free from slack.

Mount lowering arm perpendicular to the roadway or as shown in the plans. Position CCTV pole so that the camera can be safely lowered without requiring lane closures.

**POLE GENERAL NOTES:**

16 sided or more or round.

Tapered 0.14 inches per foot.

Transverse welds only allowed at the base.

One or Two sections (with telescopic field splice) is allowed.

No laminated tubes.

Up to two longitudinal seam welds are permitted.

Longitudinal seam welds within 6" of circumferential welds shall be complete penetration welds. Longitudinal seam welds at telescopic field splices shall be complete penetration welds for the splice length plus six inches. All other areas, size the partial penetration welds to at least 60% of the pole tube thickness.

Identification tag:

- Aluminum, secured to pole with stainless steel screws.
- Locate inside pole and visible from handhole.
- Provide Financial Project ID, pole height, manufacturer's name, pole base (Fy of steel) and pole base wall thickness.

Perform all welding in accordance with the American Welding Society Structural Welding Code (Steel) ANSI/AWS D1.1 (current edition).

Refer to Index No. 18108 for conduit and cabinet mounting details.

Provide fourteen #11 longitudinal bars for 4'-0" diameter drilled shafts and sixteen #11 longitudinal bars for 4'-6" diameter drilled shafts. Provide seven #5 stirrups spaced at 4" from the top of the drilled shaft and #5 stirrups spaced at 1'-6" (max.) for the rest of drilled shaft. Provide 4" cover for the top of drilled shaft and 6" cover for sides and bottom. Coordinate anchor bolt design with the shaft reinforcement and CSL tube details.

**POLE SPECIFICATIONS:**

ASTM A1011 Grade 50, 55, 60 or 65 (less than 1/4")or

ASTM A572 Grade 50, 60 or 65 (greater than 1/4")or

ASTM A595 Grade A (55 ksi yield) or Grade B (60 ksi yield).

Steel Plates and Pole Cap: ASTM A36.

Weld Metal: E70XX.

Bolts: ASTM A325, Type 1.

Handhole frame: ASTM A709 Grade 36 or ASTM A36.

Handhole cover: ASTM A1011 Grade 50, 55, 60 or 65.

Stainless steel screws: AISI Type 316.

Galvanization:

- Nuts, bolts and washers: ASTM F2329.
- All other steel: ASTM A123.

One hundred percent of full-penetration groove welds and a random 25% of partial penetration groove welds shall be inspected. Full-penetration groove weld inspection shall be performed by nondestructive methods of radiography or ultrasonics.

C:\p\project\standards\181000-s\18111-1-02.dgn  
rd960rh  
12:43:42 PM  
6/29/2012

LAST REVISION	01/01/12	DESCRIPTION:	 <b>FDOT DESIGN STANDARDS</b> 2013	<b>STEEL CCTV POLE</b>	INDEX NO.	SHEET NO.
					<b>18111</b>	<b>2</b>