

C:\projects\standards\roadway\11000-s\11300-01.dgn
 6/28/2012 11:54:33 AM rd960/h

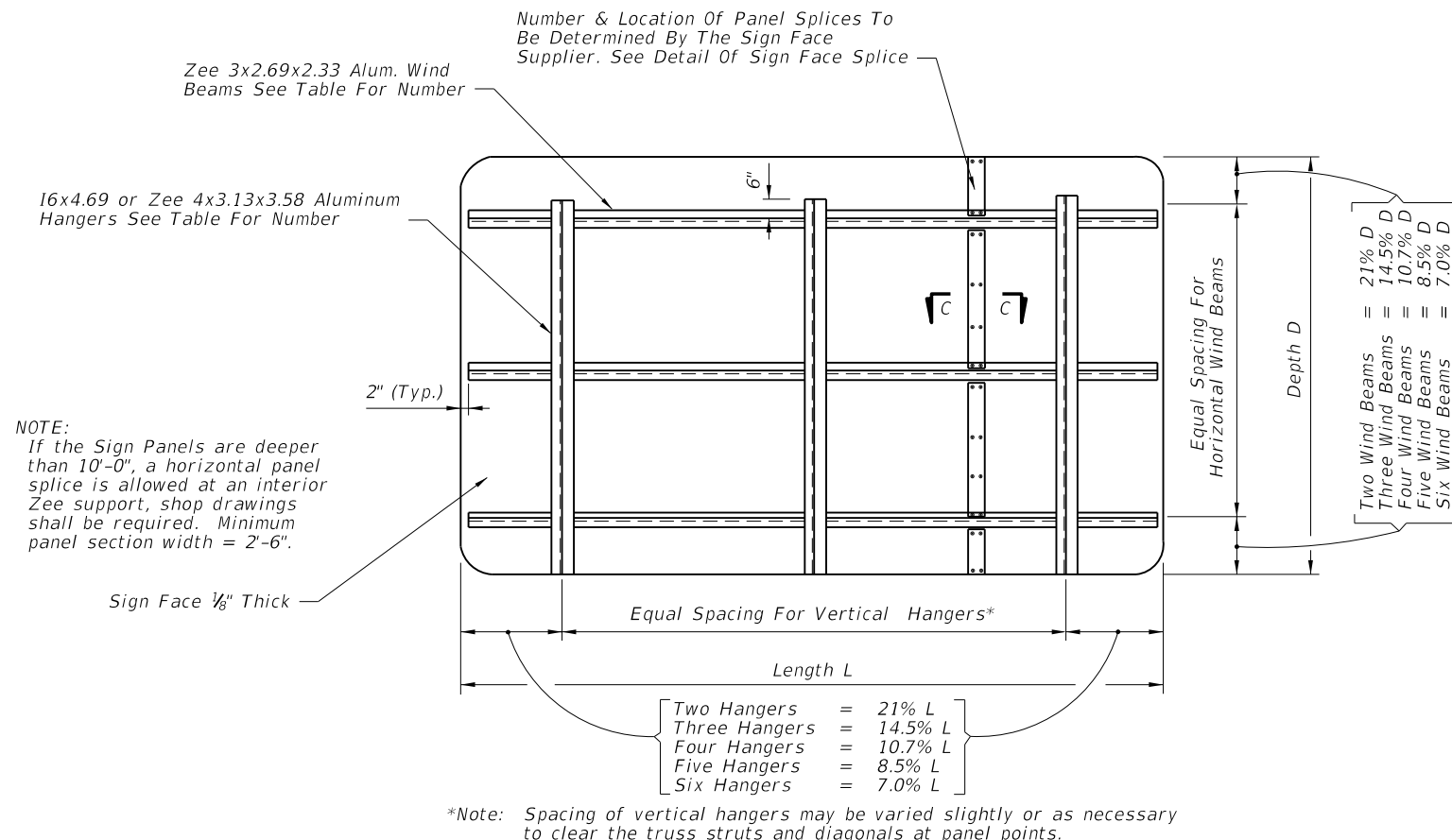

Number Of Zee 3x2.69x2.33 Horiz. Wind Beams For Sign Depth And Wind			Number Of 16x4.69 or Zee 4x3.13x3.58 Vertical Hanger Beams For Sign Length				
Wind M.P.H.	No. Beams	Max. Depth	2 Hangers	3 Hangers	4 Hangers	5 Hangers	6 Hangers
			Max Length	Max Length	Max Length	Max Length	Max Length
150	2	5'	15'	30'	45'	X	X
150	3	9'	15'	30'	45'	X	X
150	4	12'	15'	22'	30'	38'	45'
150	5	15'	15'	22'	30'	38'	45'
150	6	18'	15'	22'	30'	38'	45'
130	2	5'	15'	30'	45'	X	X
130	3	9'	15'	30'	45'	X	X
130	4	12'	15'	22'	30'	38'	45'
130	5	15'	15'	22'	30'	38'	45'
130	6	18'	15'	22'	30'	38'	45'
110	2	5'	15'	30'	45'	X	X
110	3	9'	15'	30'	45'	X	X
110	4	12'	15'	30'	38'	45'	X
110	5	15'	15'	30'	38'	45'	X
110	6	18'	15'	30'	38'	45'	X

TYPICAL SIGN FACE ELEVATION FOR OVERHEAD TRUSS

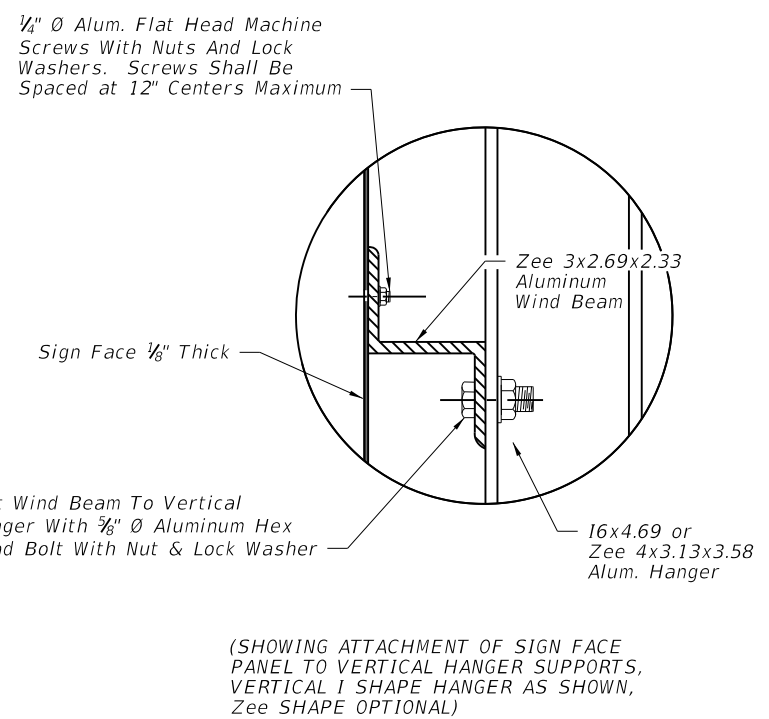
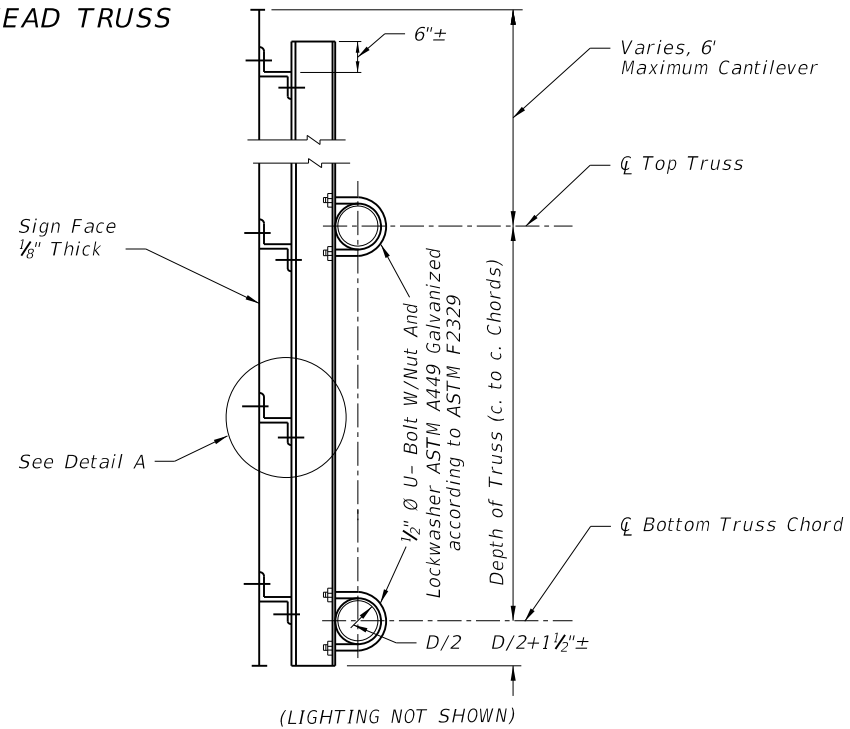
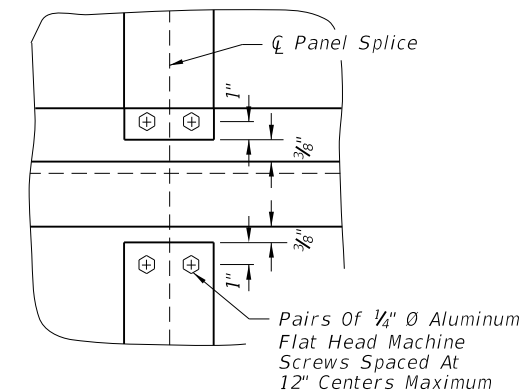
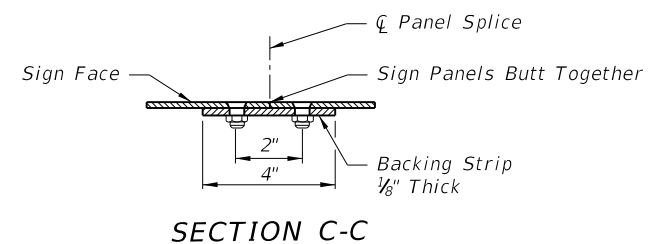

GENERAL NOTES

1. For "General Notes" covering Material Specifications see Index 11200.
2. Design based on 32 ft. maximum height to centroid of sign panel.
3. The Design Wind Speed shall conform to Wind Speed by County shown on Index 11200, Sheet 1.

DETAILS OF SIGN FACE & TRUSS CONNECTION

LAST REVISION 01/01/10	DESCRIPTION:	 FDOT DESIGN STANDARDS 2013	STEEL OVERHEAD SIGN STRUCTURES	INDEX NO. 11300	SHEET NO. 1