

4-LANE WITH TWO-WAY LEFT-TURN LANES

DESIGN SPEED (mph)	$T_a$ (FEET)	$T_d$
	ADD LANE	LANE DROP
<30	50' ( $\pm$ 1:4)	1:25
30-45		1:30
>45		1:40

Note: For locations with unrelocatable control points minimum taper rates for lane drop ( $T_d$ ) will be 1:20.

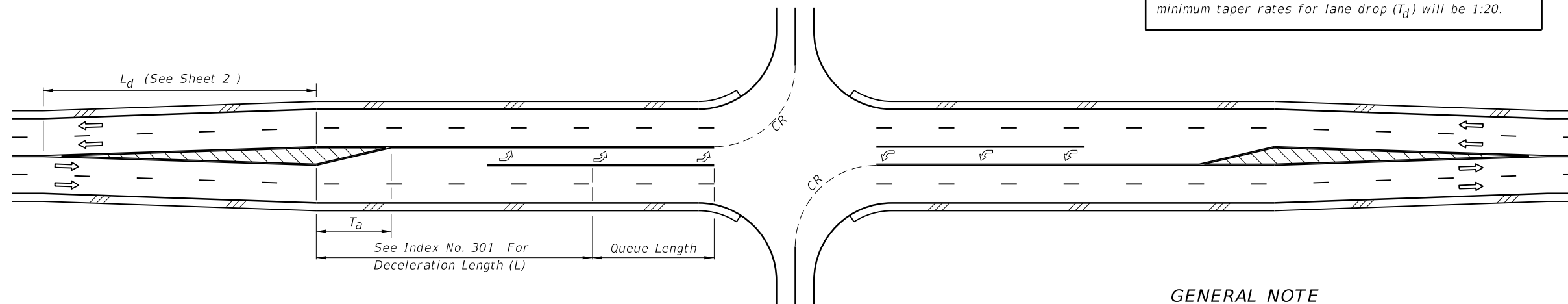

4-LANE UNDIVIDED FLARED - SYMMETRICAL

GENERAL NOTE

1. For pavement markings refer to Index No. 17346.

INTERSECTION TURNS AND STORAGE

C:\projects\standards\roadway\00500-s\00526-01.dgn 6/29/2012 10:35:15 AM rd960rh

LAST REVISION	DESCRIPTION:	 <b>FDOT DESIGN STANDARDS</b> 2013	<b>ROADWAY TRANSITIONS</b>	INDEX NO.	SHEET NO.
00				526	1

C:\projects\standards\roadway\00500-s\00526-02.dgn  
rd960r/h  
10:35:17 AM  
6/29/2012

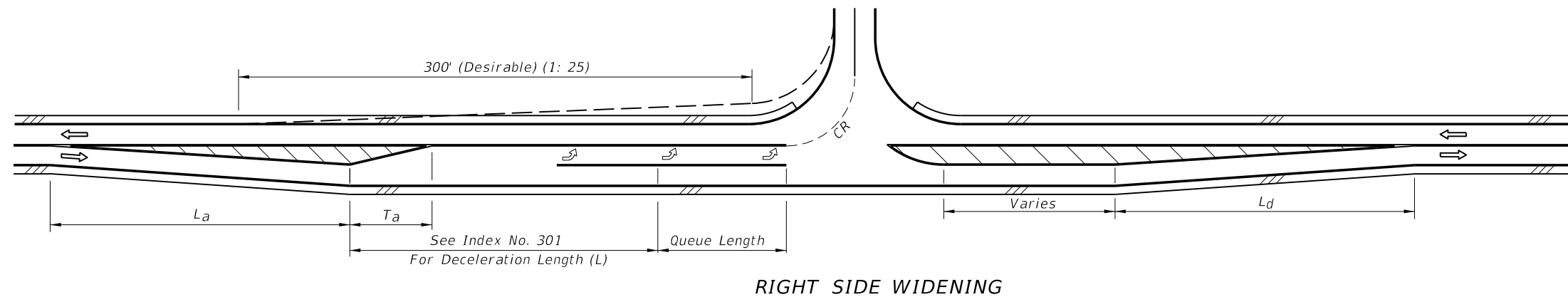
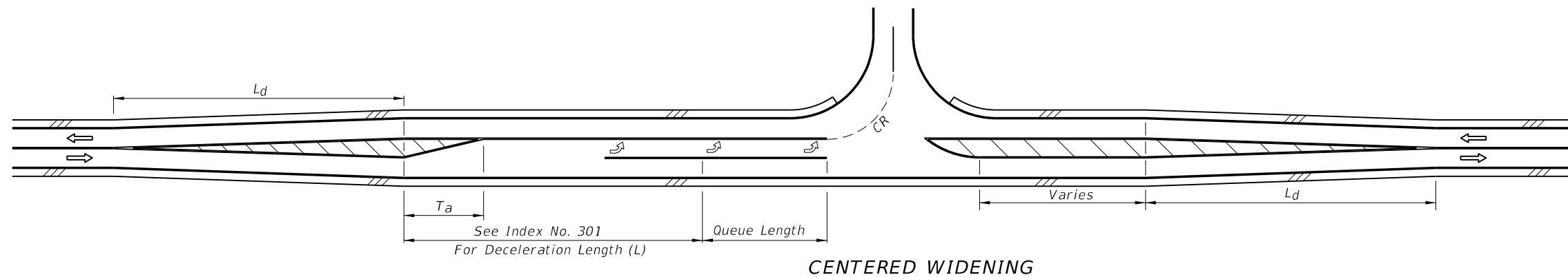
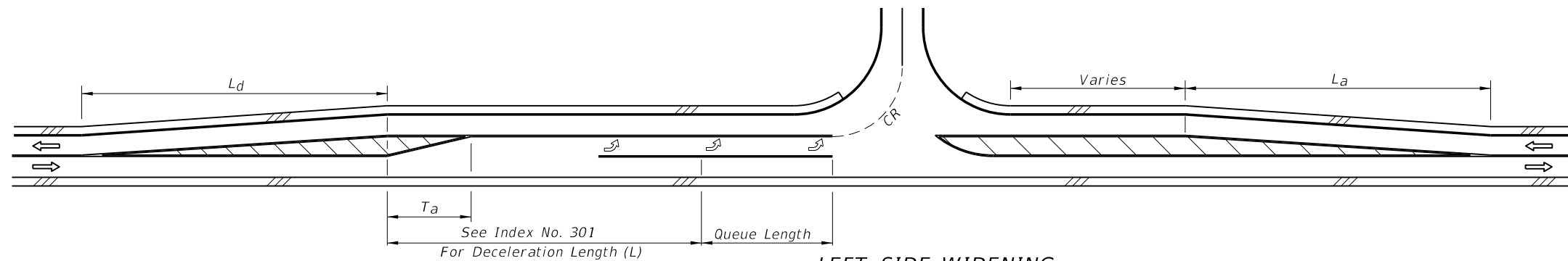

**FLARED & PAINTED LEFT TURNS FOR 2-LANE 2-WAY ROADWAYS**

DESIGN SPEED (mph)	$L_a$ (Ft.)	
	STANDARD	MINIMUM UNDER RESTRAINTS
30	180	120
40	320	150
50	500	180
60	720	240

(mph)	$L_d$ (Ft.)	
30	180	120
40	240	150
50	360	180
60	480	240

LAST REVISION	DESCRIPTION:
00	

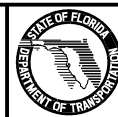

**FDOT DESIGN STANDARDS  
2013**

**ROADWAY TRANSITIONS**

INDEX NO.	SHEET NO.
526	2

6/28/2012 10:35:19 AM rd9607h C:\p\project\standards\roadway\00500-s\00526-03.dgn

$$L = \frac{WS}{2} \geq 45 \text{ mph}$$

$$L = \frac{WS^2}{120} < 45 \text{ mph}$$

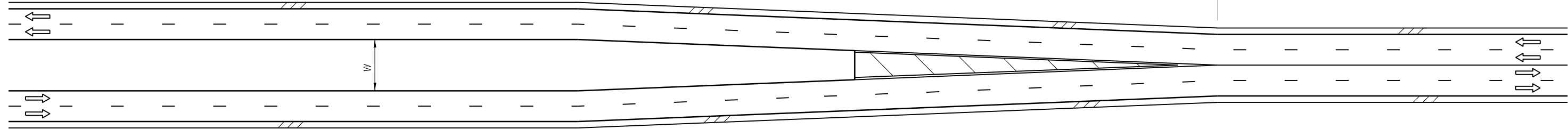

4-LANE DIVIDED TO 4-LANE UNDIVIDED

$$L = \frac{WS}{2} \geq 45 \text{ mph}$$

$$L = \frac{WS^2}{120} < 45 \text{ mph}$$

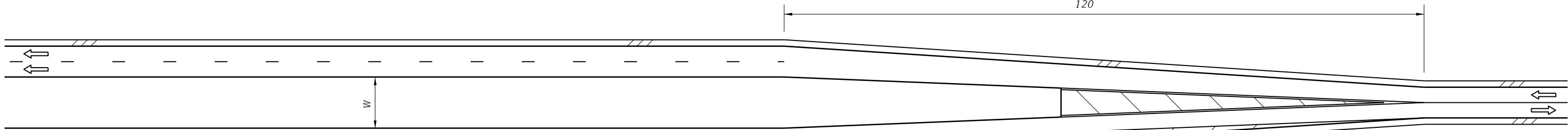

4-LANE DIVIDED TO 2-LANE UNDIVIDED

$$L = 12S \geq 45 \text{ mph}$$

$$L = \frac{S^2}{5} < 45 \text{ mph}$$

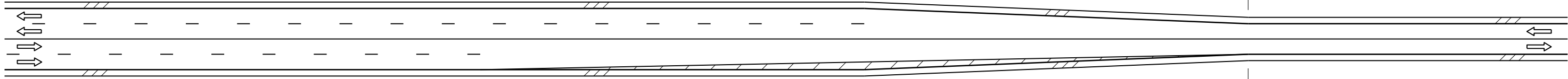

4-LANE UNDIVIDED TO 2-LANE UNDIVIDED

LANE DIVERGENCE AND CONVERGENCE FOR CENTERED ROADWAYS



LAST REVISION	REVISION	DESCRIPTION:		<b>FDOT DESIGN STANDARDS</b> 2013	<b>ROADWAY TRANSITIONS</b>	INDEX NO. <b>526</b>	SHEET NO. <b>3</b>
00							

C:\projects\standards\roadway\00500-s\00526-04.dgn  
 rd960rh  
 10:35:21 AM  
 6/29/2012

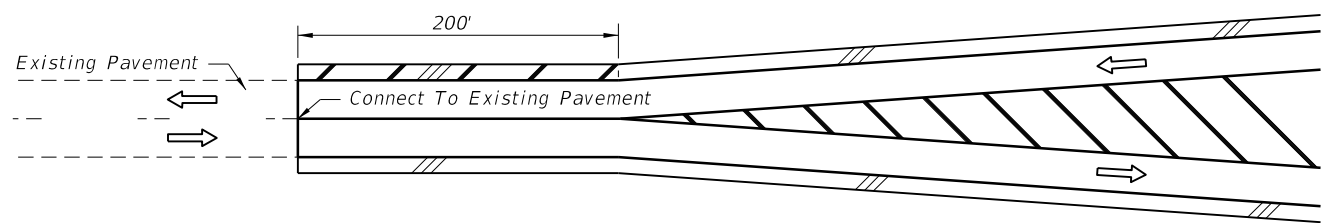

CONNECTING FLARE WITH PAVED SHOULDERS TO EXISTING ROADWAY WITHOUT PAVED SHOULDERS

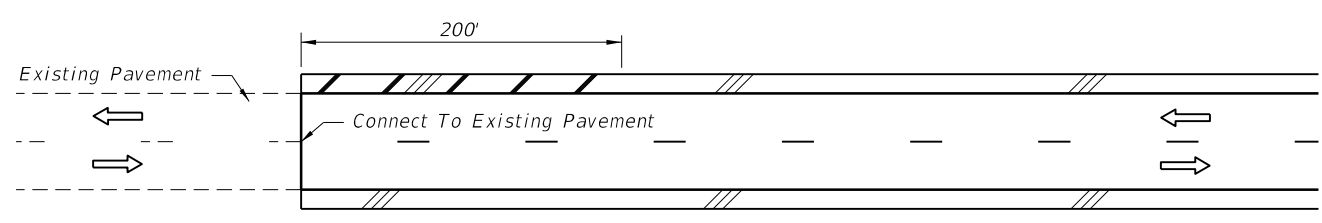

CONNECTING SIMILAR WIDTH PAVEMENTS

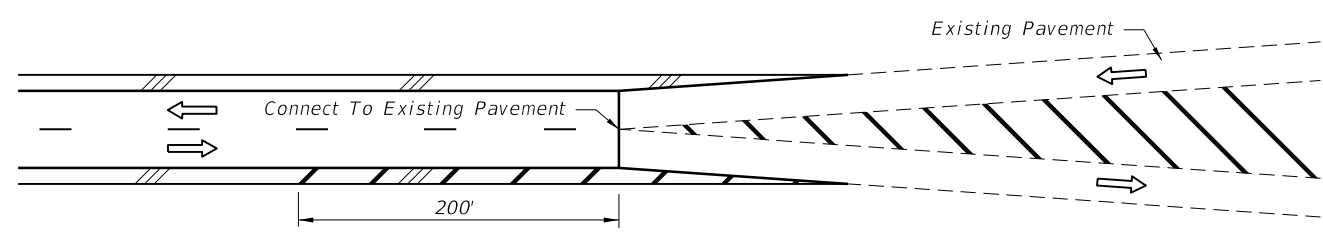

CONNECTING ROADWAY WITH PAVED SHOULDERS TO EXISTING SYMMETRICAL FLARE WITHOUT PAVED SHOULDERS

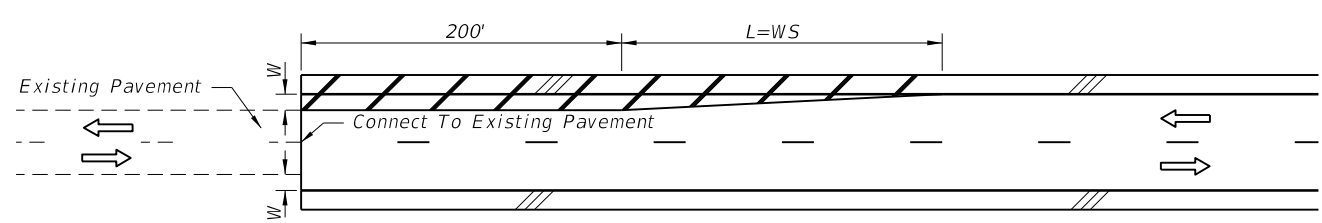

CONNECTING DIFFERENT WIDTH PAVEMENTS

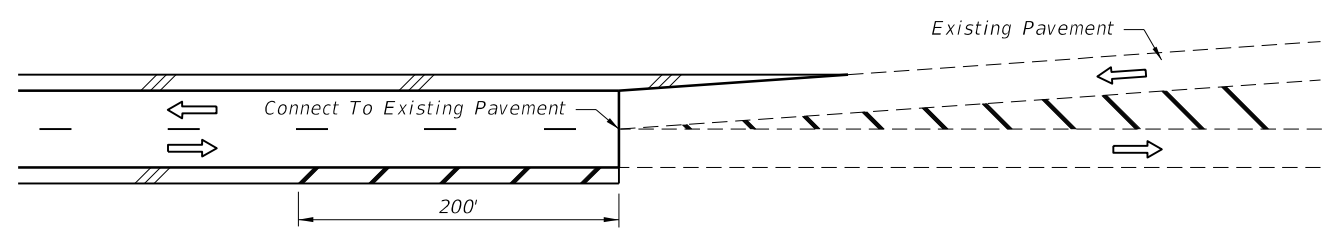

CONNECTING ROADWAY WITH PAVED SHOULDERS TO EXISTING ASYMMETRICAL FLARE WITHOUT PAVED SHOULDERS

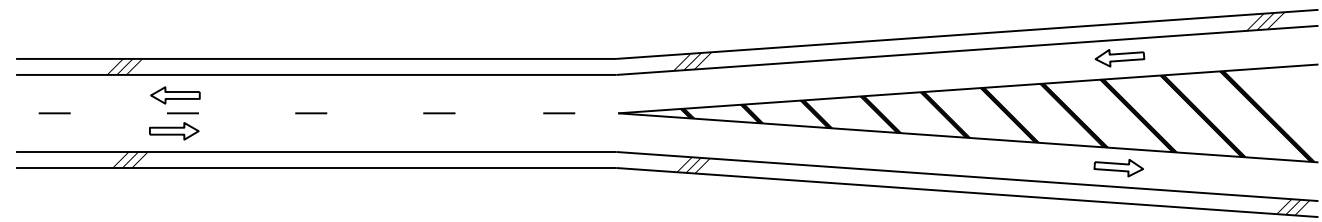

FLARED - PAVED SHOULDERS

$S = \text{Design speed (mph)}$

PAVED SHOULDER TREATMENT AT TRANSITIONS AND CONNECTIONS

LAST REVISION	DESCRIPTION:	 FDOT DESIGN STANDARDS 2013	ROADWAY TRANSITIONS	INDEX NO.	SHEET NO.
00				526	4

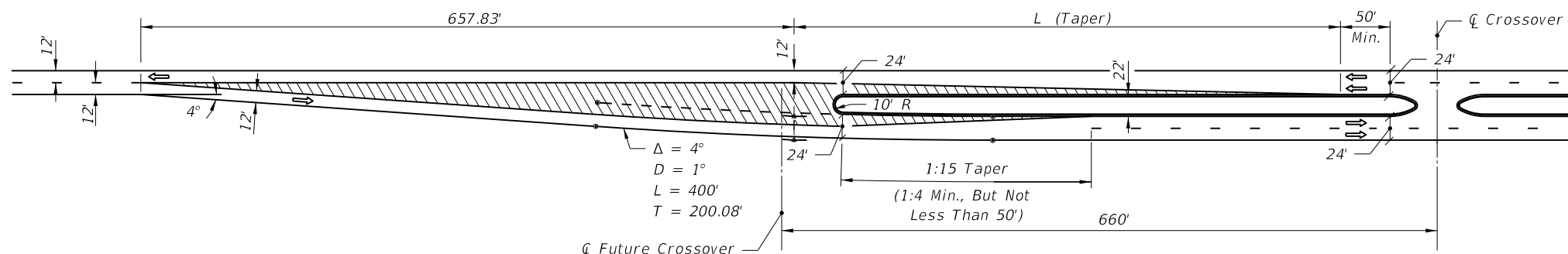

22' MEDIAN

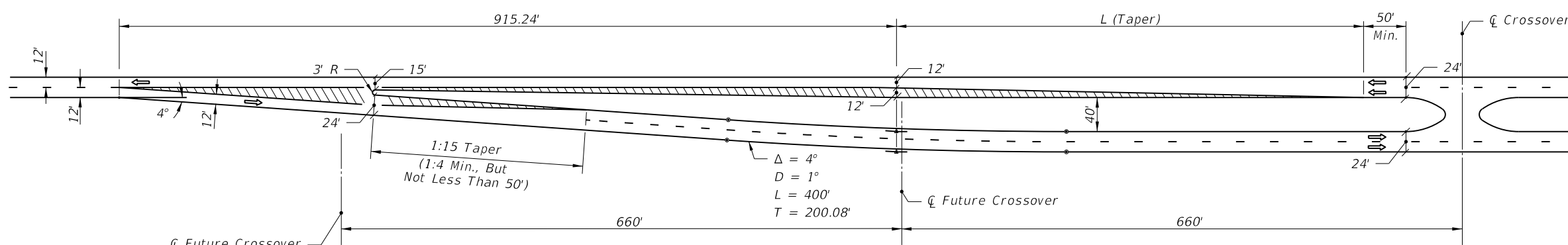

40' MEDIAN

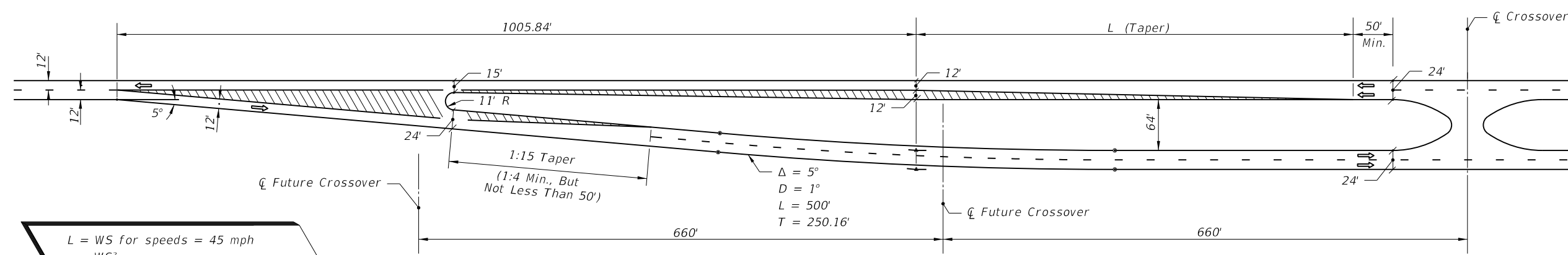

64' MEDIAN

$L = WS$  for speeds = 45 mph  
 $L = \frac{WS^2}{60}$  for speeds  $\leq 40$  mph  
 Where:  
 W=Width of lateral transition in feet.  
 S=Design speed.

**NOTES FOR SHEETS 5 THRU 8**

1. The transition details as represented on sheets 5 thru 8 are intended as guidelines only. The transition lengths, curve data, nose radii and offsets are valid only for tangent alignment, design speeds  $\leq 45$  mph, the median widths and lane widths shown.
2. Approach lane departures ( $\Delta = 5^\circ$ ) are suitable for design speeds up to 60 mph. Interior curves ( $D = 1^\circ$ ) are suitable for normal crown for design speeds up to 50 mph. Merging curves ( $D \geq 5^\circ$ ) will require superelevation.
3. The geometrics of these schemes are associated with the standard subsectional spacing for side roads, but in any case will require modification to accommodate side road location, multilane and/or divided side roads, oblique side roads, crossover widths, storage and speed change lane requirements, and, other related features.

LEFT ROADWAY CENTERED ON APPROACH ROADWAY

TWO LANE TO FOUR LANE TRANSITION

C:\projects\standards\roadway\00500-s\00526-05.dgn  
 r0960rh  
 10:35:23 AM  
 6/28/2012

LAST REVISION	DESCRIPTION:	 <b>FDOT DESIGN STANDARDS</b> <b>2013</b>	<b>ROADWAY TRANSITIONS</b>	INDEX NO.	SHEET NO.
00				526	5

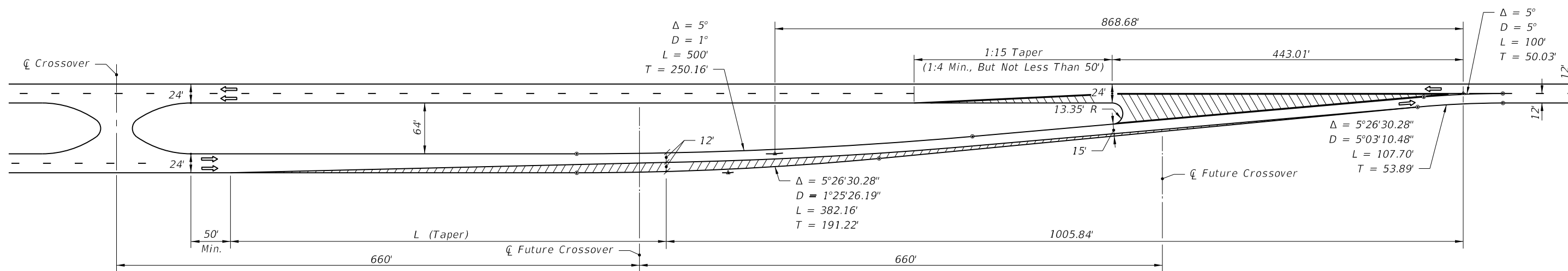
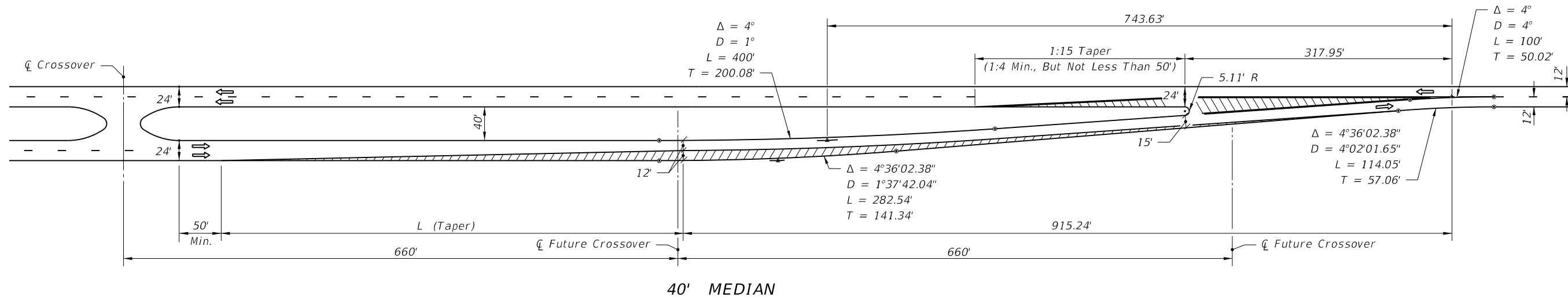
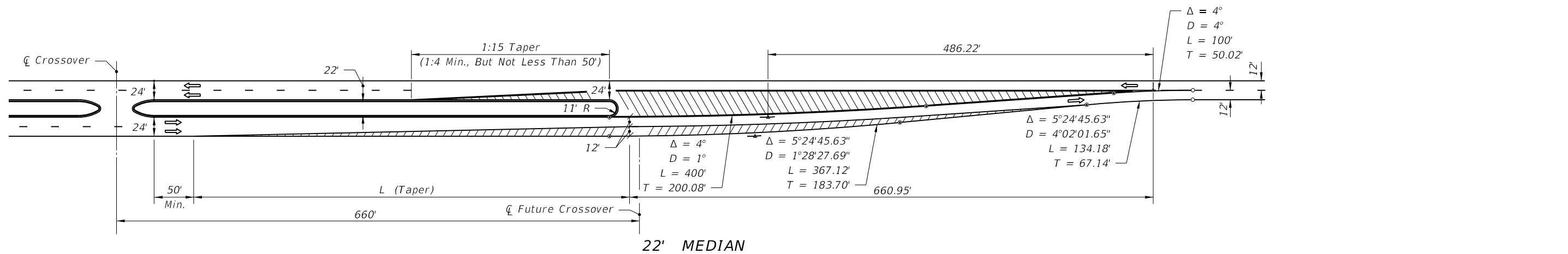

$L = WS$  for speeds = 45 mph  
 $L = \frac{WS^2}{60}$  for speeds  $\leq 40$  mph  
 Where:  
 W = Width of lateral transition in feet.  
 S = Design speed.

**64' MEDIAN**  
 LEFT ROADWAY CENTERED ON THRU ROADWAY  
 FOUR LANE TO TWO LANE TRANSITION

C:\projects\standards\roadway\00500-s\00526-06.dgn  
 rd960r/h  
 10:35:25 AM  
 6/28/2012

LAST REVISION	DESCRIPTION:	 <b>FDOT DESIGN STANDARDS</b> <b>2013</b>	<b>ROADWAY TRANSITIONS</b>	INDEX NO.	SHEET NO.
00				526	6

C:\projects\standards\roadway\00500-s\00526-07.dgn  
 rd9607h  
 10:35:27 AM  
 6/29/2012

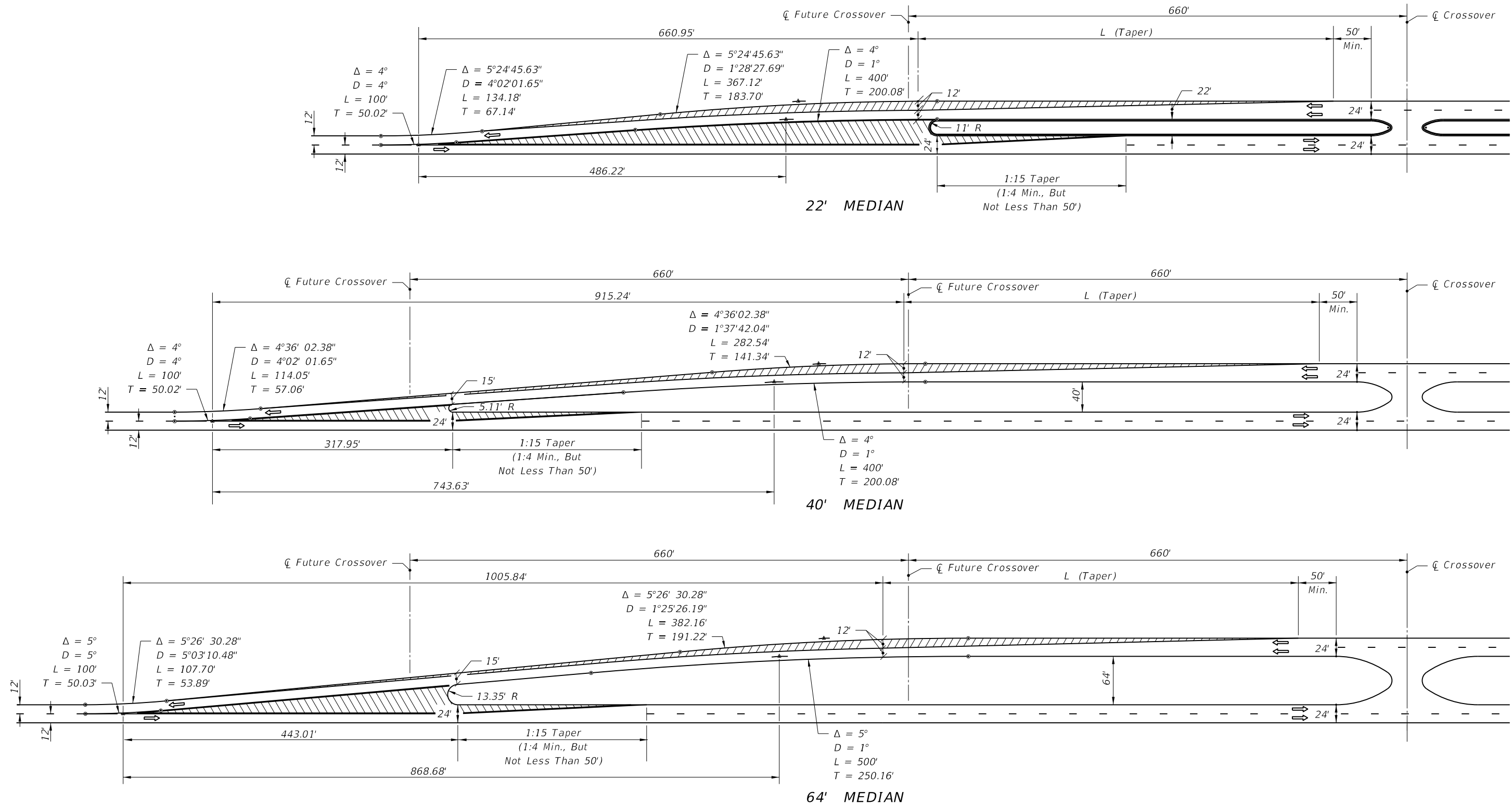

$L = WS$  for speeds = 45 mph  
 $L = \frac{WS^2}{60}$  for speeds  $\leq 40$  mph  
 Where:  
 W = Width of lateral transition in feet.  
 S = Design speed.

RIGHT ROADWAY CENTERED ON APPROACH ROADWAY  
 TWO LANE TO FOUR LANE TRANSITION

LAST REVISION	DESCRIPTION:	 <b>FDOT DESIGN STANDARDS</b> <b>2013</b>	<b>ROADWAY TRANSITIONS</b>	INDEX NO.	SHEET NO.
00	REVISION			526	7

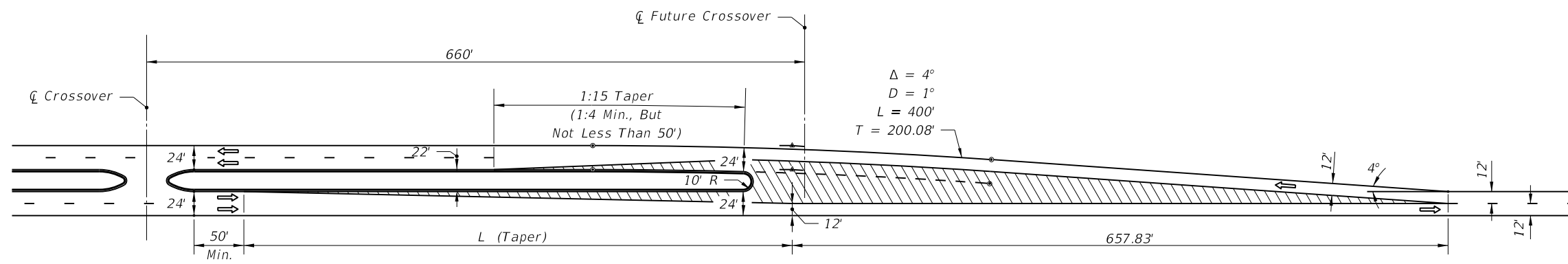

22' MEDIAN

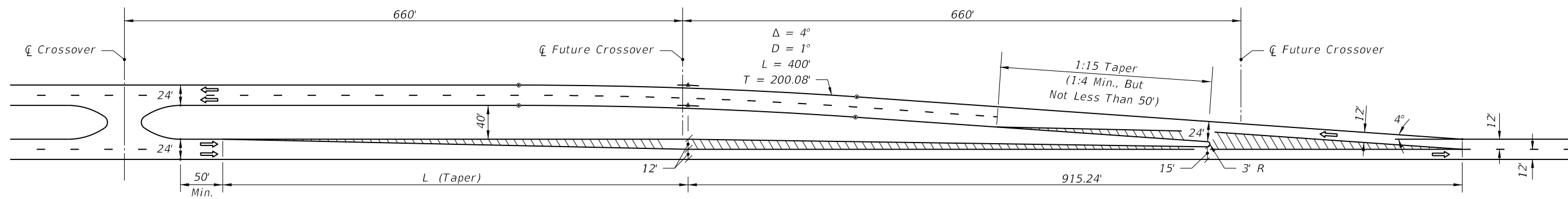

40' MEDIAN

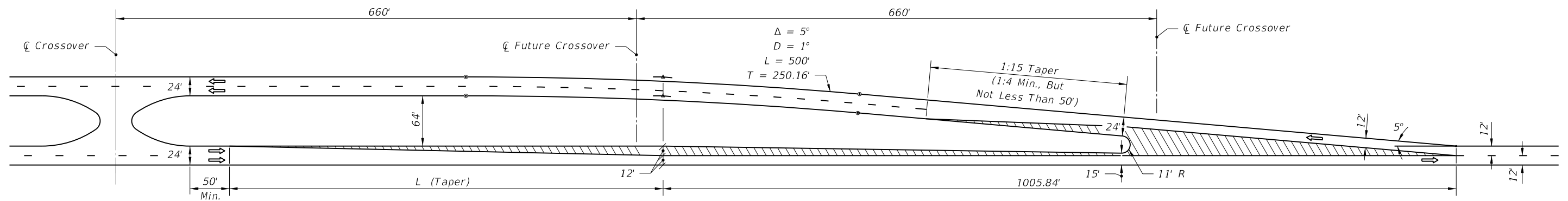

64' MEDIAN

$L = WS$  for speeds = 45 mph  
 $L = \frac{WS^2}{60}$  for speeds  $\leq 40$  mph  
 Where:  
 W = Width of lateral transition in feet.  
 S = Design speed.

RIGHT ROADWAY CENTERED ON THRU ROADWAY  
 FOUR LANE TO TWO LANE TRANSITION

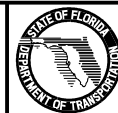

FDOT DESIGN STANDARDS  
 2013

ROADWAY TRANSITIONS

LAST REVISION	REVISION	DESCRIPTION:
00		

INDEX NO.	SHEET NO.
526	8

C:\projects\standards\roadway\00500-s\00526-08.dgn  
 6/28/2012 10:35:29 AM rd9607h