

NOTE: For Sections QQ & TT, see Index 410.

PLAN VIEW

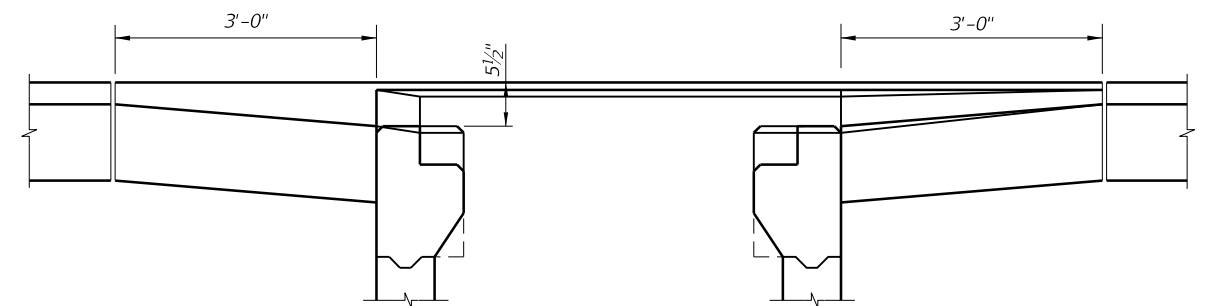

SECTION CC

PICTORIAL VIEW

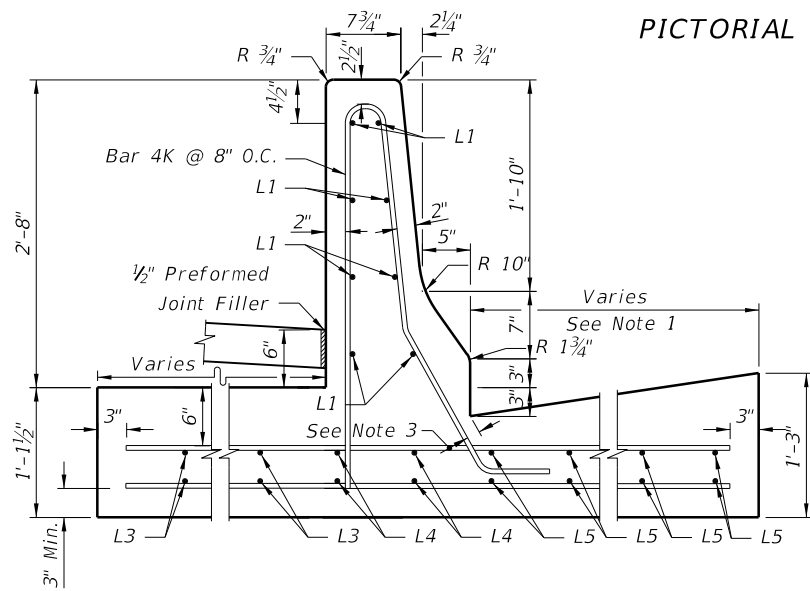

SECTION AA

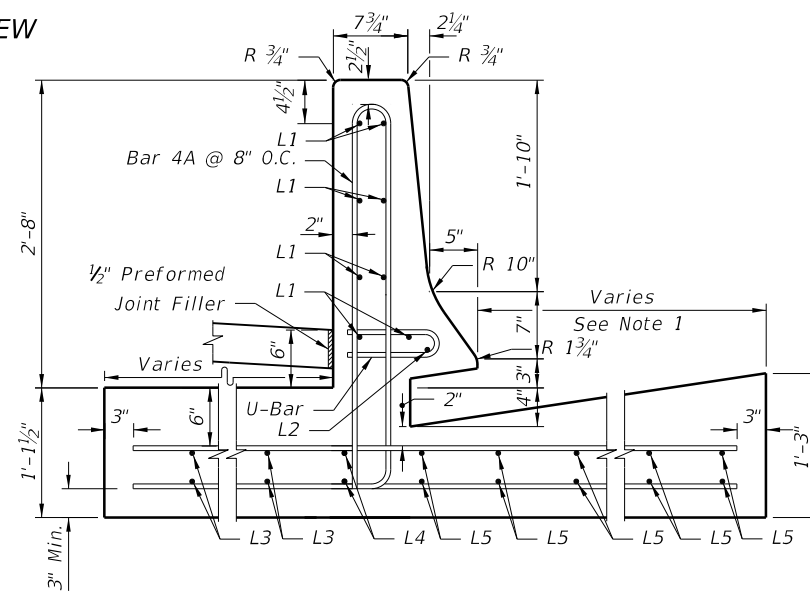

SECTION BB

- NOTES:
1. Distance = 1'-6" With Bike Lane, Or 2'-6" Without Bike Lane.
 2. For Double Throat Inlet, Section BB replaces Section AA.
 3. Field Bend Bar 4K To Maintain 2" Minimum Concrete Cover.

GENERAL NOTES

1. This inlet to be used in conjunction with Concrete Barrier Wall, Curb and Gutter, Index No. 410. The inlet is suitable for bicycle and occasional pedestrian traffic with extended crossbar or bar stub (see INSETS B & B ALTERNATE). Inlet should not be placed in a pedestrian way.
2. All reinforcing is Grade 60 bars. For equivalent area of welded wire fabric for inlet, see Index No. 201. Reinforcing shall have 2" min. cover unless otherwise shown. Bars shall be trimmed or bent to provide 1 1/2" clearance around pipe openings. Cost for additional reinforcing in barrier wall to be included in cost of concrete barrier wall.
3. Barrier wall shall be Class II Concrete, finished surface in accordance with General Note 1, Sheet 1, Index No. 410.
4. All exposed edges and corners shall be 3/4" chamfer or tooled to 1/4" radius.
5. A flat 18"x2 1/2" drainage slot shall be constructed at the inlet centerline when the inlet is located in a curb sag. For drainage slot construction, no more than two bars shall be trimmed or deleted such as type: 4A, 4K, and U-Bar. On each side of drainage slots, vertical & horizontal bars shall be placed to provide 2" concrete cover.
6. Recommended maximum pipe sizes are 18" longitudinal and 30" transverse. For larger pipe, use Alternate B bottoms, Index No. 200.
7. Grates can be fabricated with reticulate bars or with either 1/2" welded or 3/8" electroforged cross bars and bearing bars as detailed on Sheet 3.
8. When Alternate G grate is specified in plans, the grate is to be hot-dip galvanized after fabrication according to Specification 962-9.
9. For Pay Item purposes, the depth of the barrier wall inlet shall be computed using the center of box grate elevation, less the flow line elevation of the lowest pipe flow line or to the top of the sump floor elevation.
10. All dimensions are for both precast and C-I-P inlets unless otherwise noted.
11. Inlets to be paid for under the contract unit price for Inlets, Barrier Wall, Rigid, Curb & Gutter, Each.
12. Concrete Barrier Wall to be paid for under the contract unit price for Shoulder Concrete Barrier Wall, Rigid-Curb & Gutter, LF.

6/29/2012 7:23:13 AM rd960rh C:\projects\standards\roadway\02200-s\02219-01.dgn

LAST REVISION	01/01/12	DESCRIPTION:	 FDOT DESIGN STANDARDS 2013	CONCRETE BARRIER WALL INLET	INDEX NO.	SHEET NO.
					219	1

6/28/2012 7:23:16 AM rd960rh C:\projects\standards\roadway\02200-s\00219-02.dgn

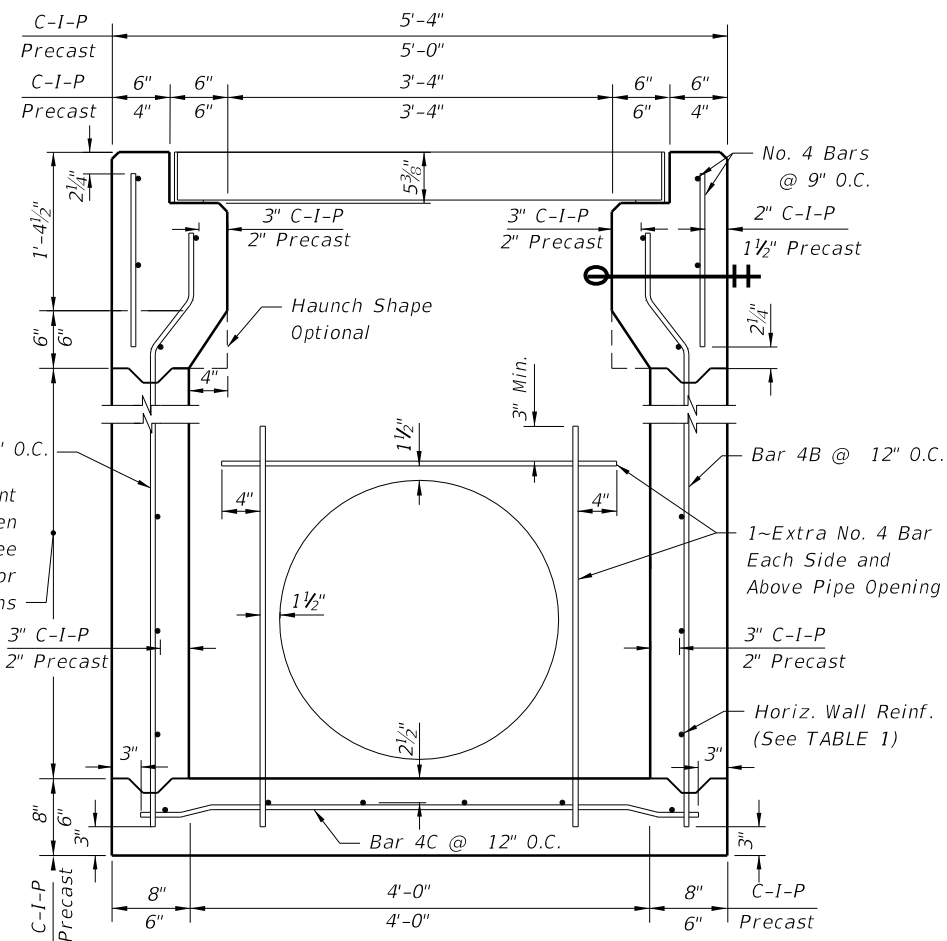

(18" Dia. Pipe Opening Shown)
SECTION DD

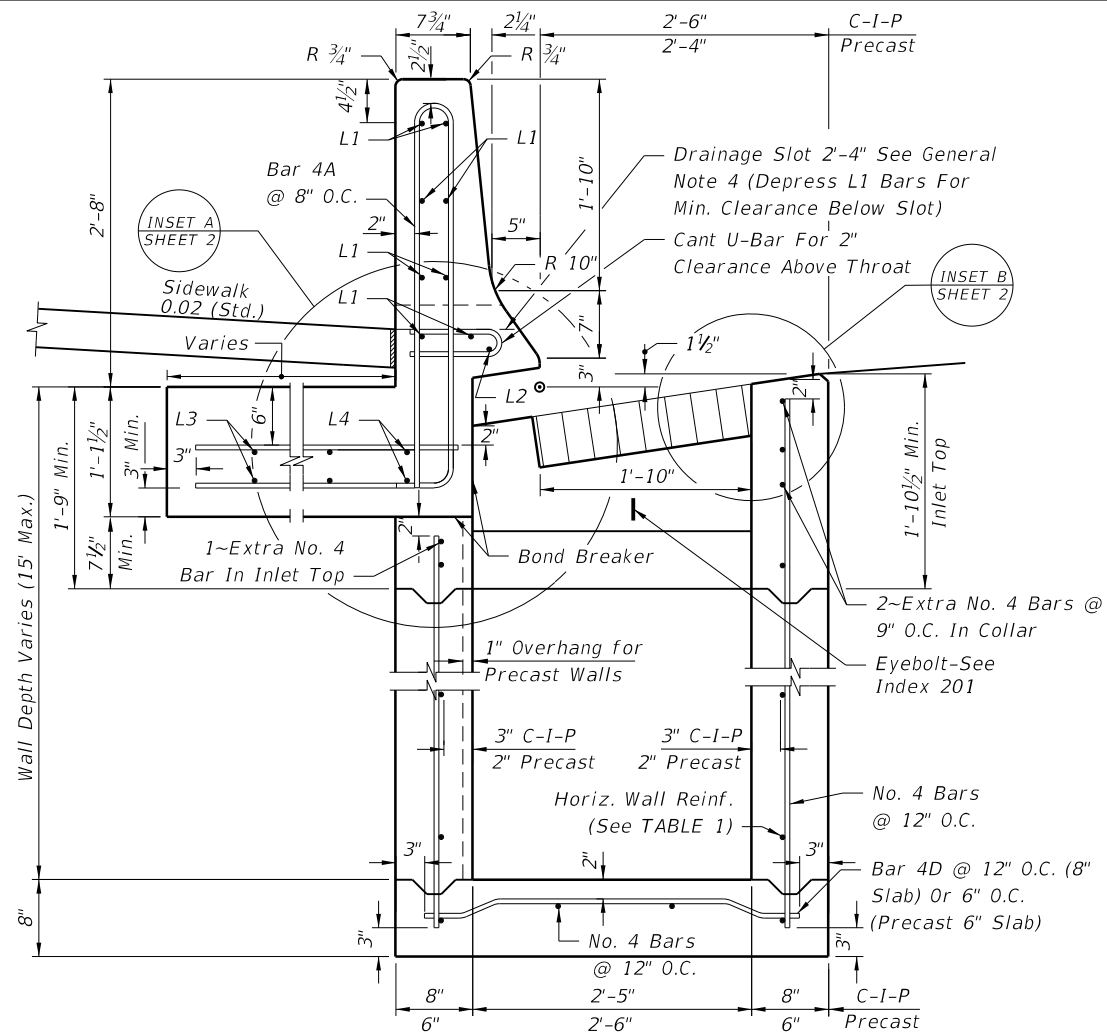

(Pipe Opening Not Shown)
SECTION EE

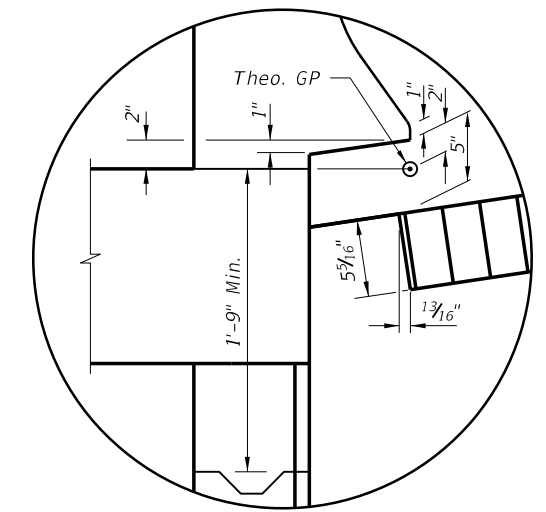

INSET A
Install Grate With Extended CROSSBAR OPTIONS (Sheet 3) To Front Of Inlet

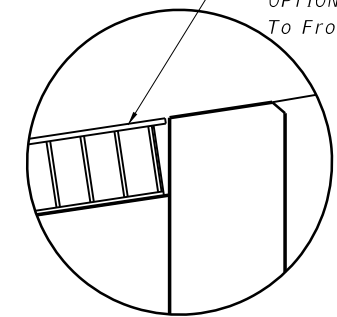

INSET B

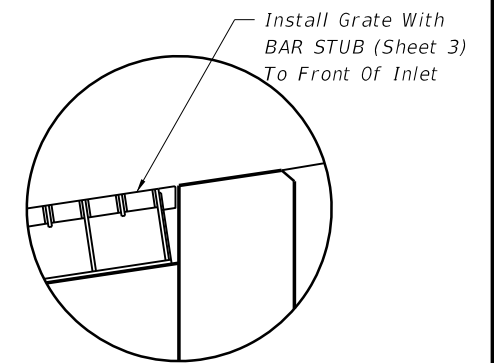

INSET B (ALTERNATE)

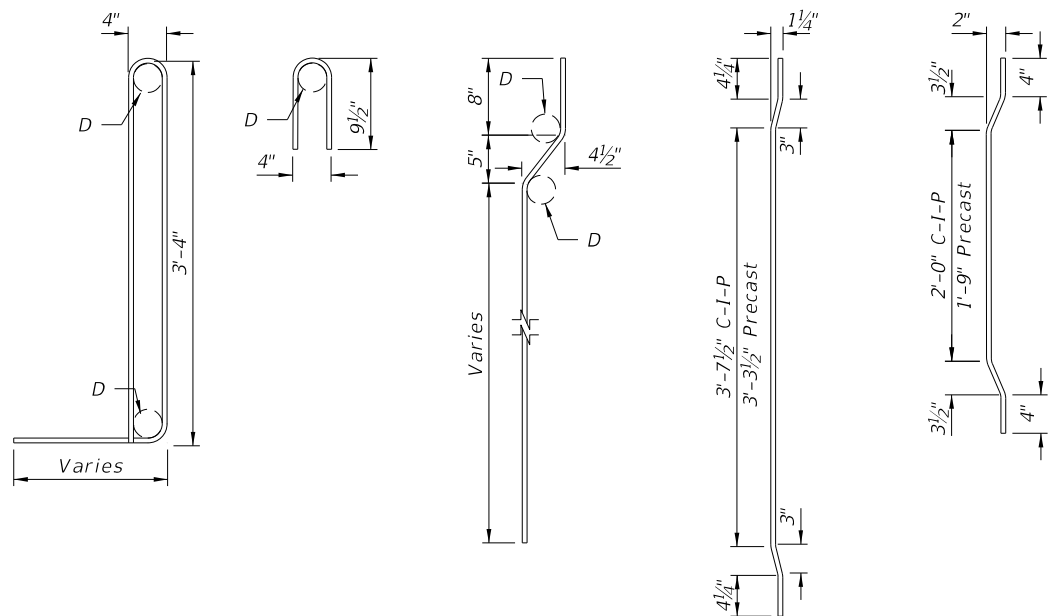

BAR 4A U-BAR BAR 4B BAR 4C BAR 4D
BAR BENDING DIAGRAMS

REINFORCING NOTES:

1. Bars L1: Length 11'-1", Straight @ 8" O.C.
2. Bars L2: Length: 8'-4" (Single Throat) 11'-0" (Double Throat) @ 8" O.C.
3. Bars L3 & L4: Length 11'-1" Field Bend For 4" Drop (Top Bars) 3" Drop (Bottom Bars) @ 8" O.C.
4. Bars L5: Length 2'-8" Field Bend For Drop Same As L3 & L4 @ 8" O.C.
5. U Bars @ 8" O.C.

WALL DEPTH C-I-P PRECAST	SCHEDULE	AREA (in. ² /ft.)	MAX. SPACING	
			BARS	WWR
0'-4"	A12	0.20	12"	8"
4'-9"	A6	0.20	6"	5"
9'-15"	B5.5	0.24	5 1/2"	5"
10'-15"	C6.5	0.37	6 1/2"	6"

HORIZONTAL WALL REINFORCING SCHEDULE (TABLE 1)

NOTES:

1. For DOWELED TRANSVERSE CONSTRUCTION JOINT WHEN ABUTTING SEGMENT(S) LESS THAN 40' IN LENGTH, see DETAIL B, Index 410.
2. For Additional Information on "STANDARD BAR BENDING DETAILS," See Index 21300.

LAST REVISION	DESCRIPTION:
01/01/12	



CONCRETE BARRIER WALL INLET

INDEX NO.	SHEET NO.
219	2

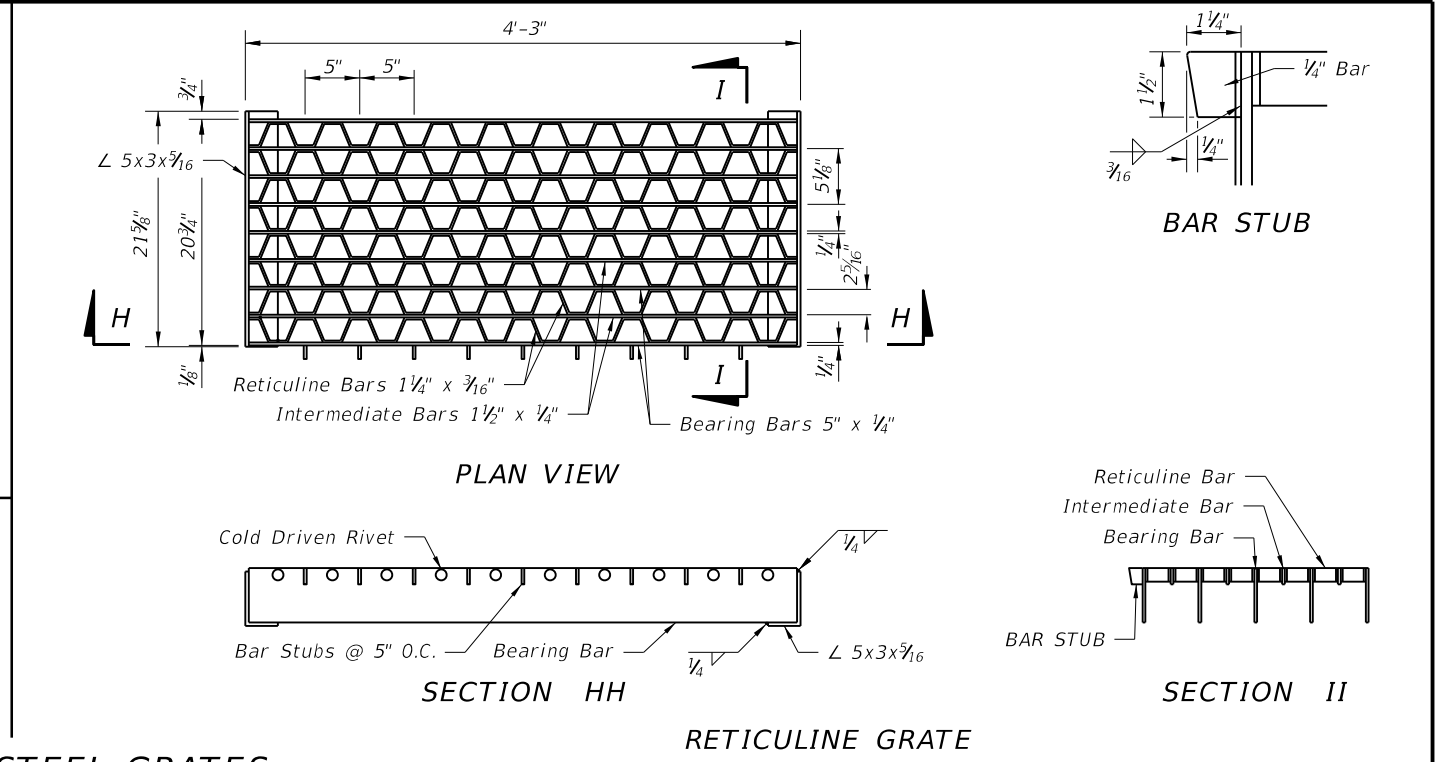
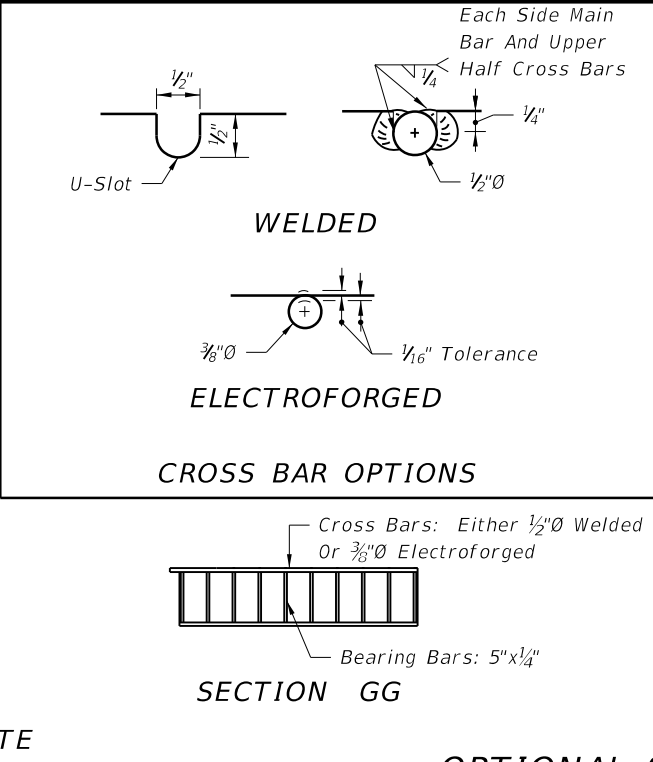
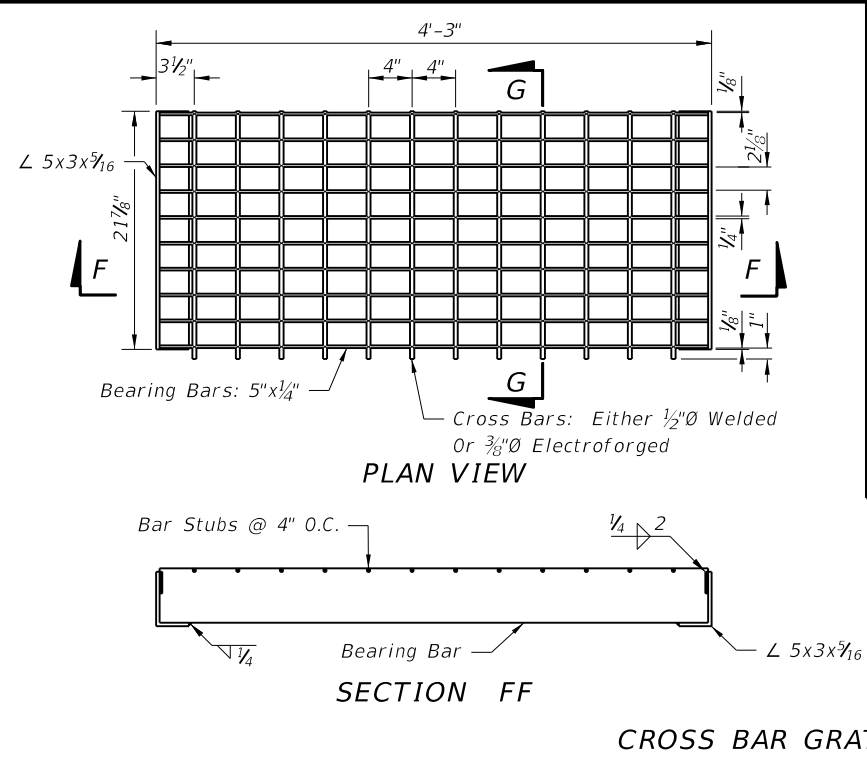

OPTIONAL STEEL GRATES

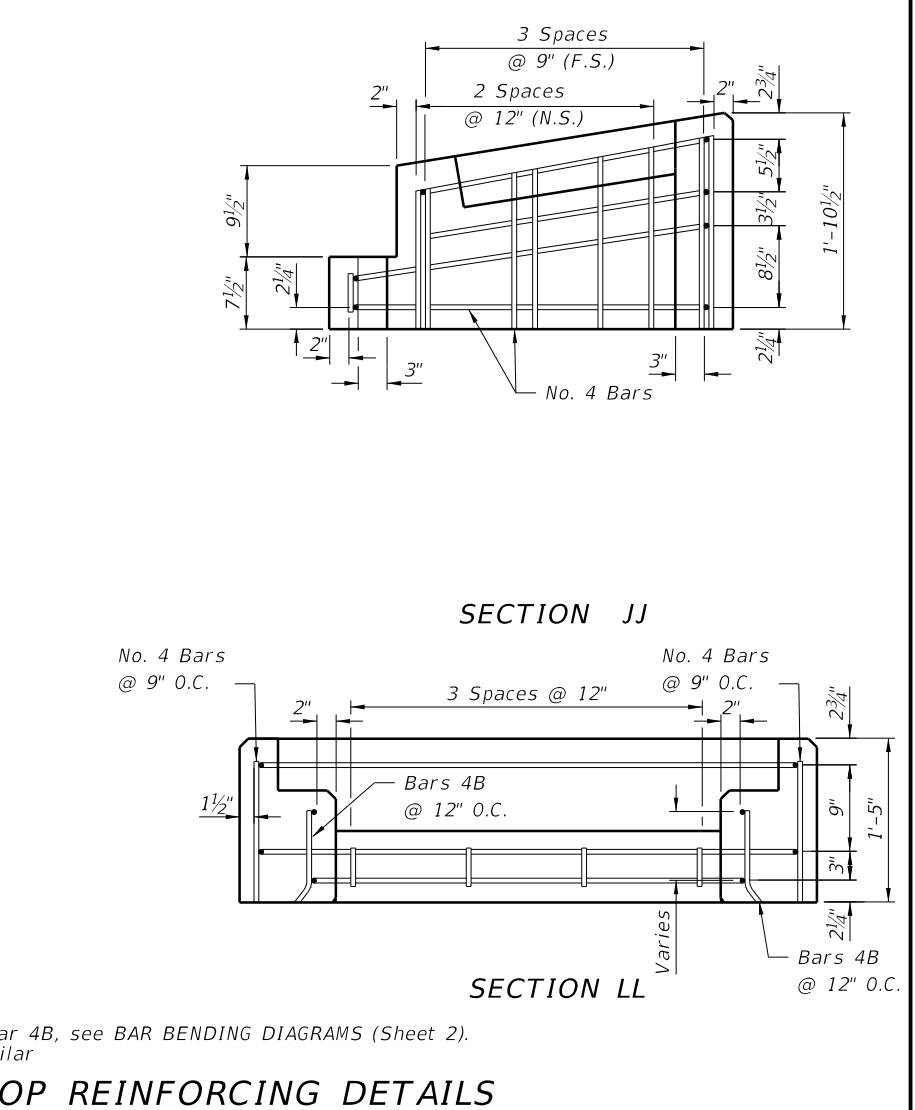
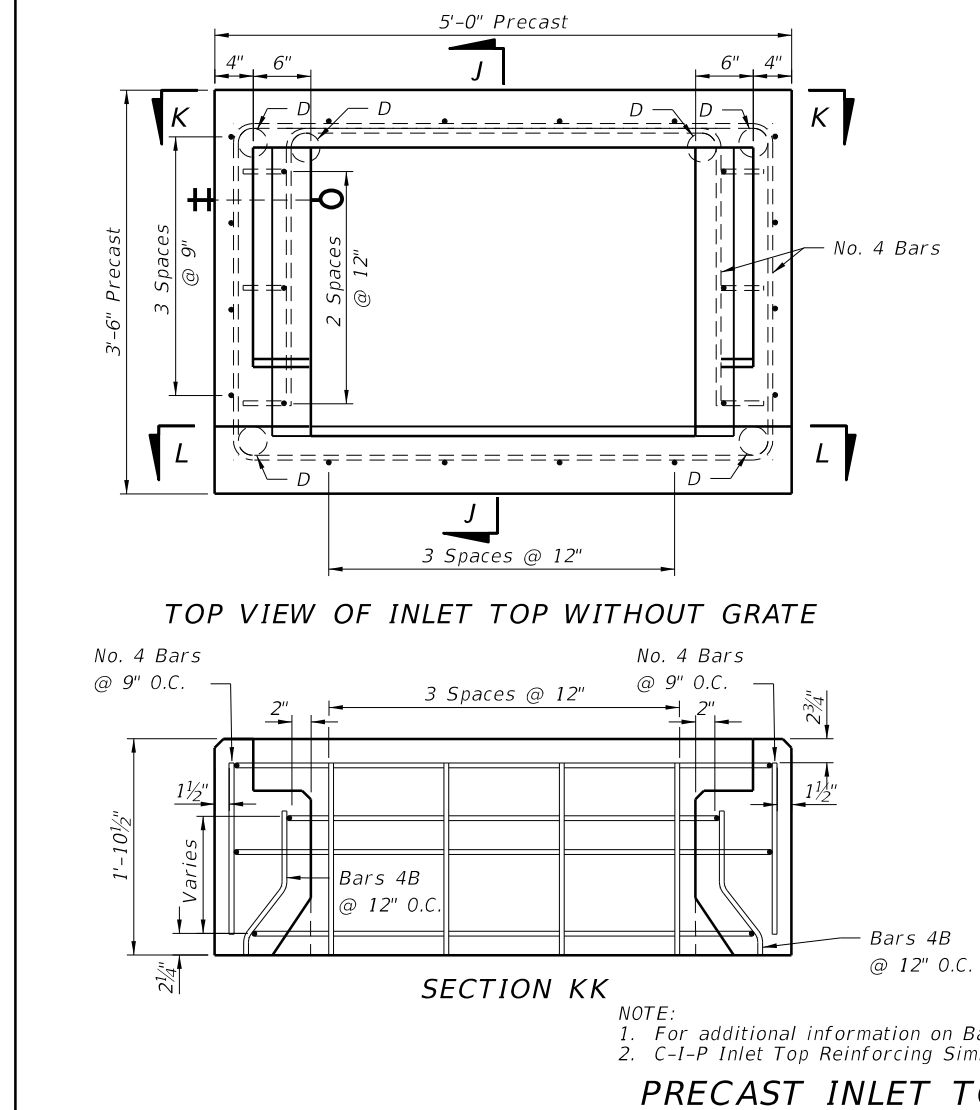
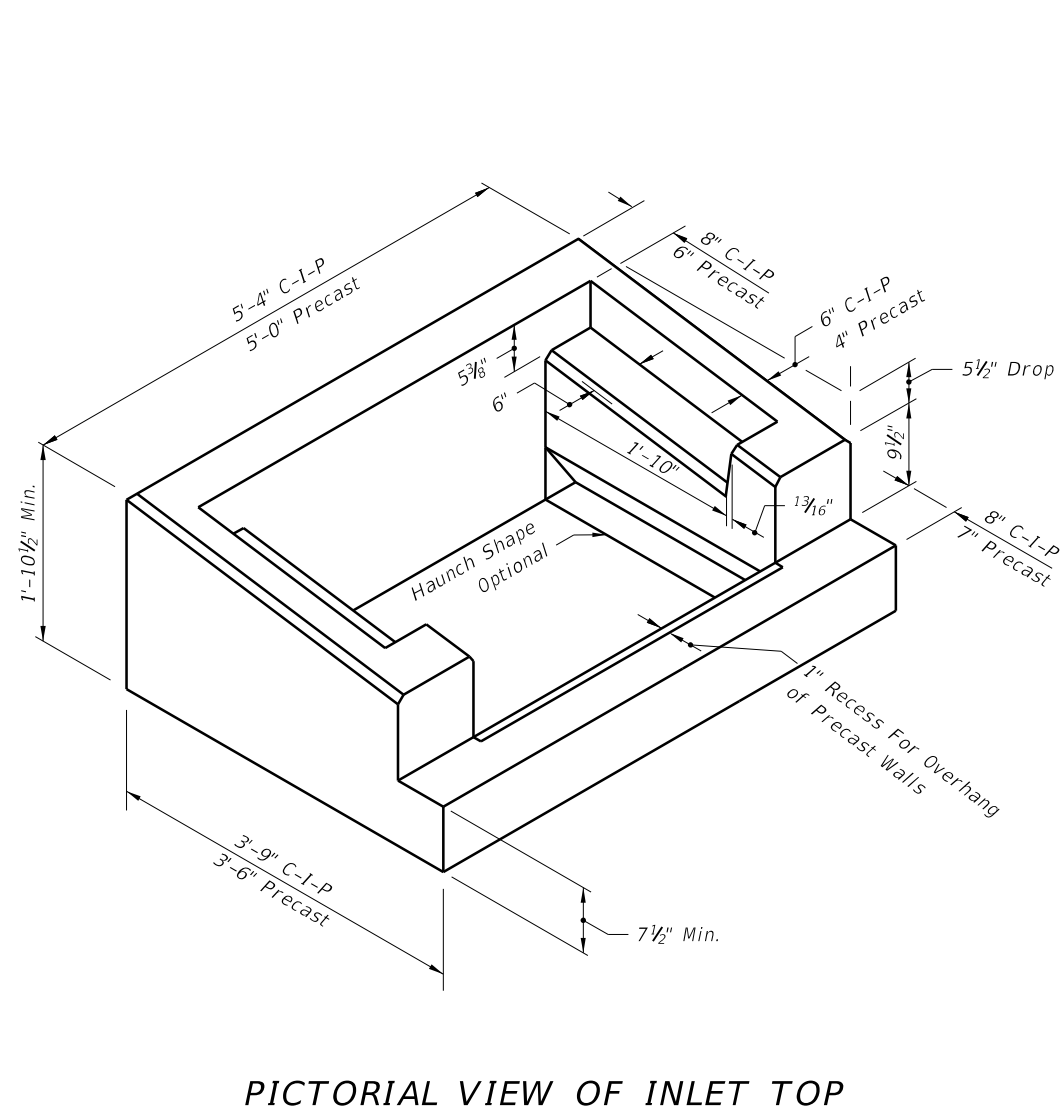

NOTE:
 1. For additional information on Bar 4B, see BAR BENDING DIAGRAMS (Sheet 2).
 2. C-I-P Inlet Top Reinforcing Similar

PRECAST INLET TOP REINFORCING DETAILS

C:\p\projects\standards\roadway\02200-s\0219-03.dgn
 rd960rh
 7:23:19 AM
 6/28/2012

LAST REVISION	DESCRIPTION:	 FDOT DESIGN STANDARDS 2013	CONCRETE BARRIER WALL INLET	INDEX NO.	SHEET NO.
01/01/12				219	3