

LOW SIDE SUPERELEVATION PAVEMENT WARP FOR SHOULDERS IN SUPERELEVATION
HIGH SIDE TRANSITION PAVEMENT WARP FOR SHOULDERS IN SUPERELEVATION

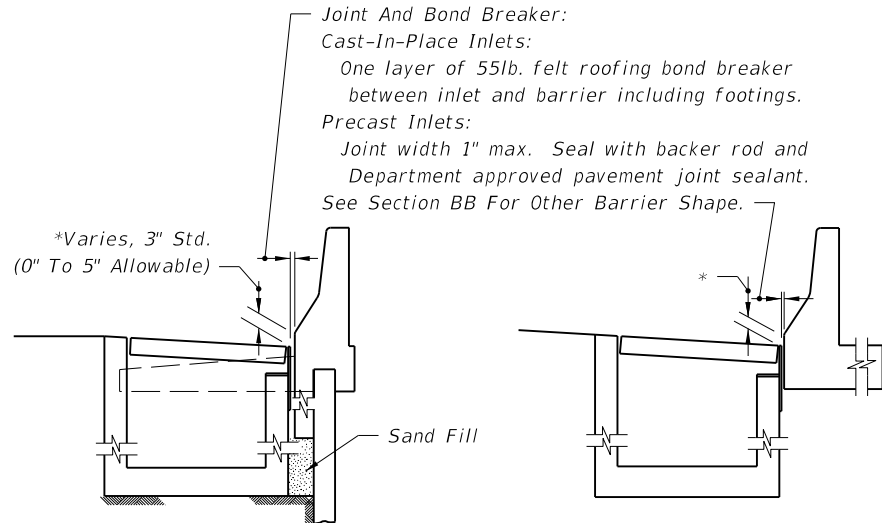

BARRIER WALL / RETAINING WALL INLET SECTION AT WALLS
SINGLE FACE ROADWAY BARRIER INLET SECTION AT WALLS

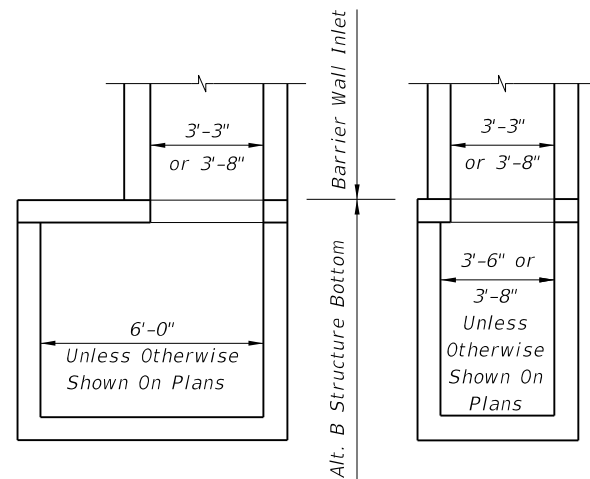

Note: Alt. B Structure Bottom Only. See Index No. 200.

INLET WITH STRUCTURE BOTTOM

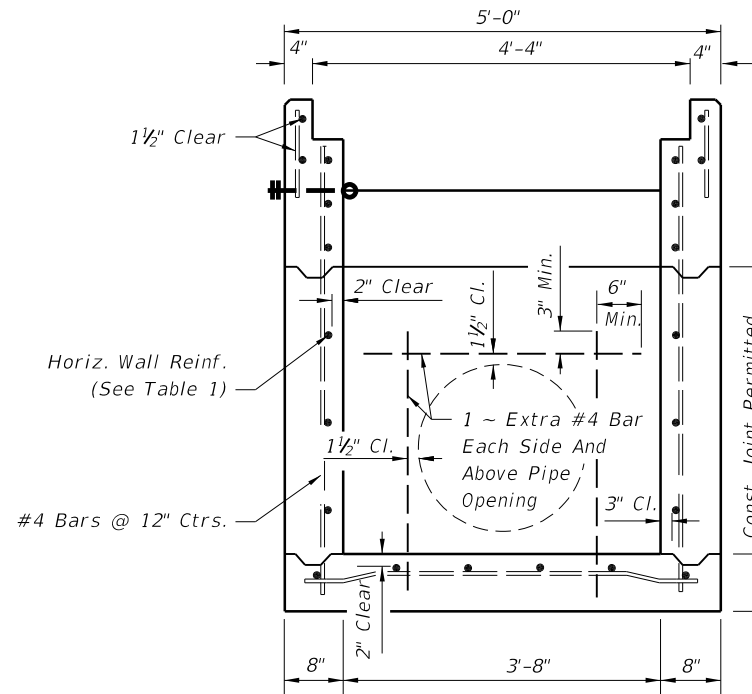

(Pipe Opening Shown)
SECTION AA (WITHOUT GRATE)

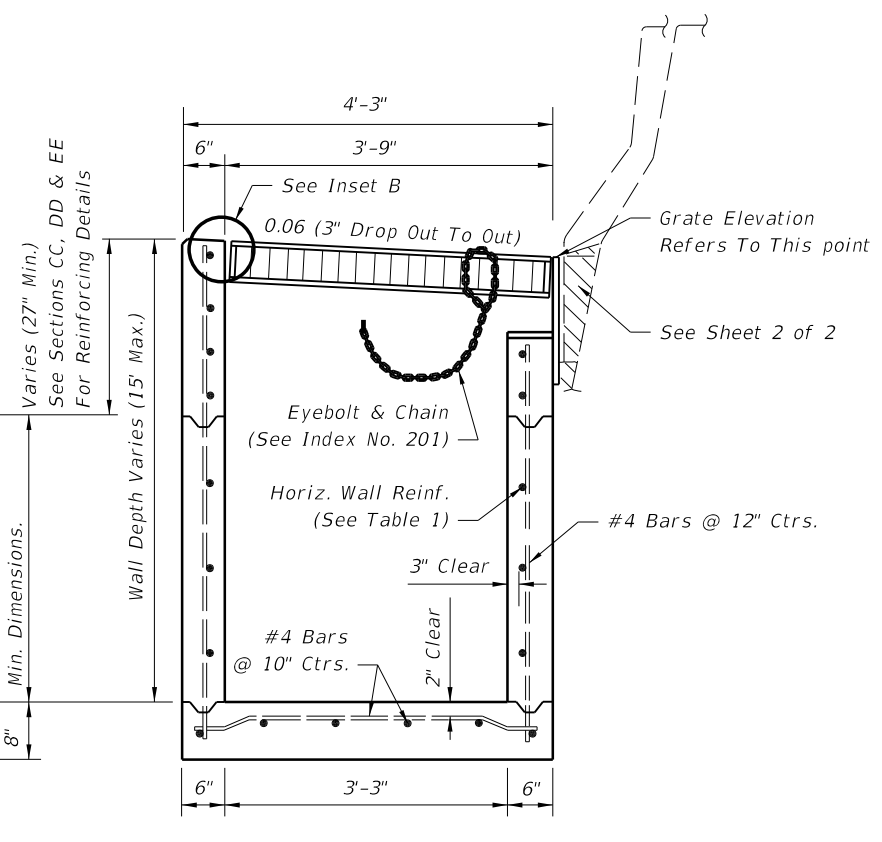

(Pipe Opening Not Shown)
SECTION BB

GENERAL NOTES

1. This inlet is primarily intended for use adjacent to concrete barrier walls on paved shoulders. Use of the inlet adjacent to other wall types shall be approved by the Drainage Engineer. The inlet is suitable for bicycle and occasional pedestrian traffic, with roller bar installation (see inset B) but should not be placed in a designated pedestrian travel way. It is not intended for use in curb and gutter or other areas where throated inlets are required, nor areas subject to high debris.
2. Inlets located in embankments constructed with earth anchored retaining wall shall be designed with minimum depths to reduce adverse impact on the anchorage system. Runs of pipe parallel to and near anchored wall shall be avoided wherever practical. Special coordination must be exercised during the design and construction of storm water systems within anchored wall systems.
3. Inlet bottoms and/or tops may be either precast or cast-in-place. Whether cast as a single unit or as multiple segments, and whether precast or cast-in-place, the upper 2'-3" of the inlet shall be reinforced in accordance with sections CC, DD and EE.
4. All exposed edges and corners shall be 3/4" chamfer or tooled to 1/4" radius.
5. When Alternate G grate is specified in the plans, the grate is to be hot-dip galvanized after fabrication. Field installation of the filler bar called for in Inset B will not be permitted, thereby requiring tolerance adjustment during fabrication and/or casting, or, matching grate to structure prior to galvanizing.
6. All reinforcing is Grade 60 bars. See Index No. 201 for equivalent area of welded wire fabric.
7. All dimensions are for both precast and cast-in-place inlets unless otherwise noted.
8. For supplemental details see Index Nos. 200 and 201.
9. Inlets to be paid for under the contract unit for Inlets (Barrier Wall), Each.

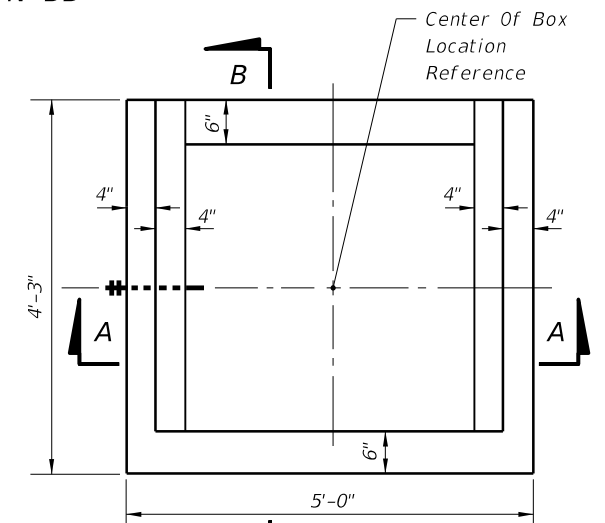

TOP VIEW (WITHOUT GRATE)

HORIZONTAL WALL REINFORCING SCHEDULE (TABLE 1)

WALL DEPTH	SCHEDULE	AREA (in. ² /ft.)	MAX. SPACING	
			BARS	WWF
0'-5'	A12	0.20	12"	8"
5'-10'	A6	0.20	6"	5"
10'-15'	A4	0.20	4"	3"
10'-15'	B5.5	0.24	5 1/2"	5"

C:\projects\standards\roadway\00200-s\00218-01.dgn
r0960rh
7:22:29 AM
6/28/2012

C:\projects\standards\roadway\00200-s\00218-02.dgn
 r0960rh
 7:22:31 AM
 6/29/2012

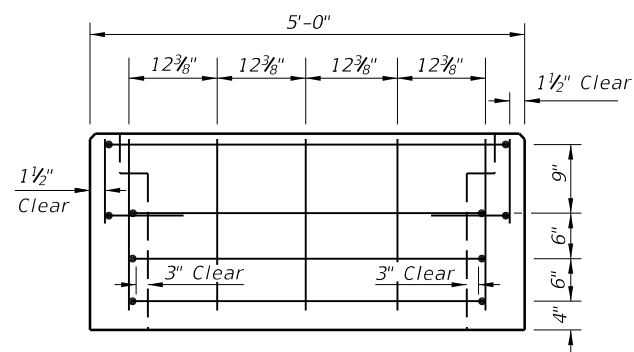

SECTION CC

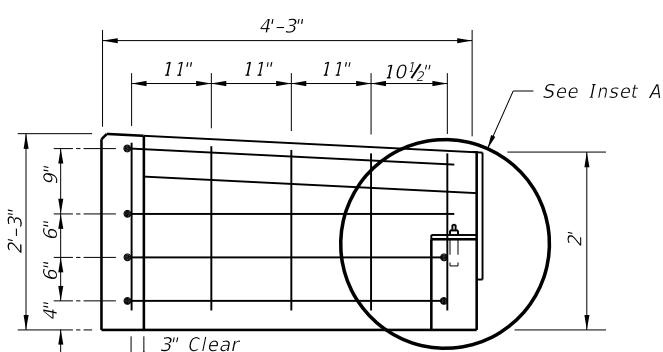

SECTION DD

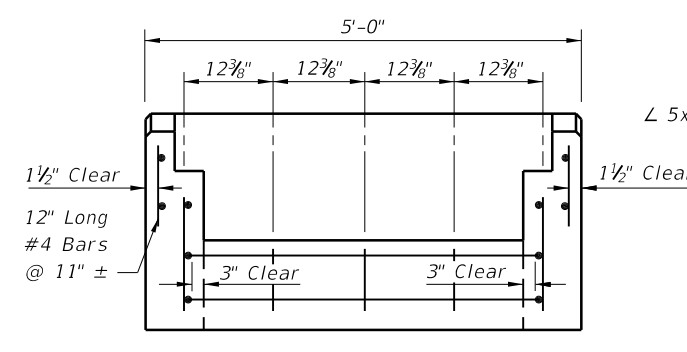

SECTION EE

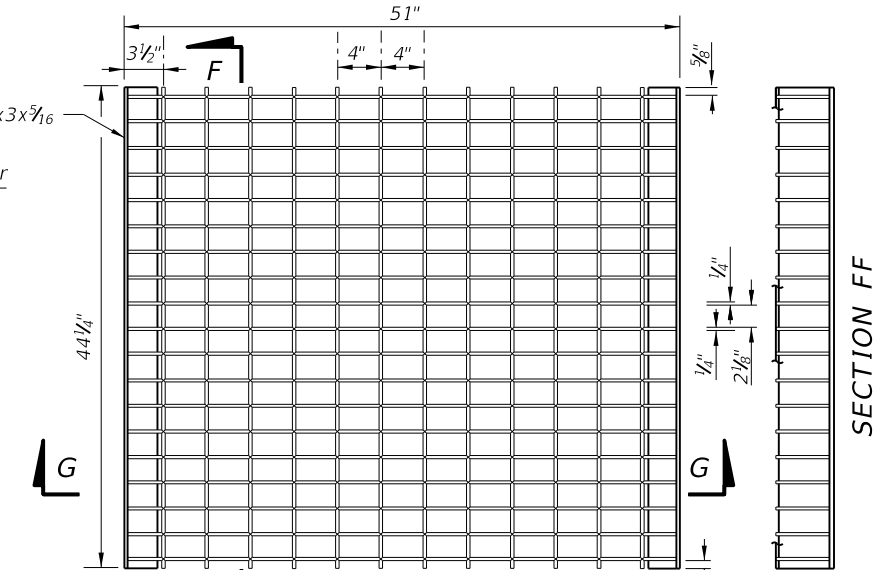

SECTION FF
Main Bars: 5" x 1/4"
Cross Bars: Either 3/8" Electroforged or 1/2" Welded
TOP VIEW

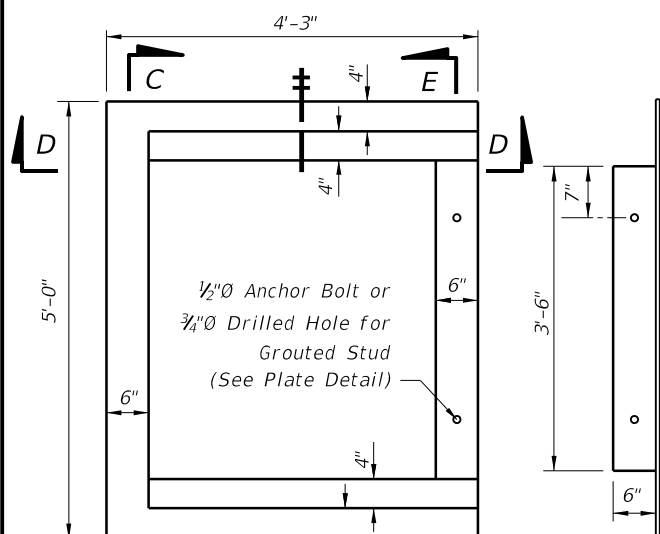

TOP VIEW OF INLET WITHOUT GRATE

TOP VIEW OF METAL PLATE

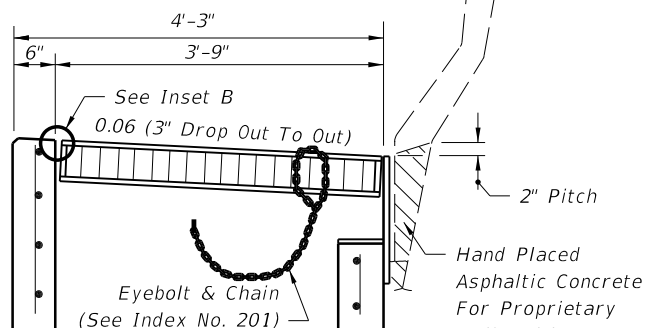

TRANSVERSE SECTION WITH GRATE & PLATE

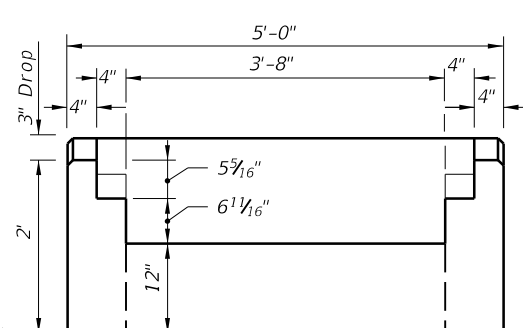

BACK VIEW WITHOUT BACK PLATE

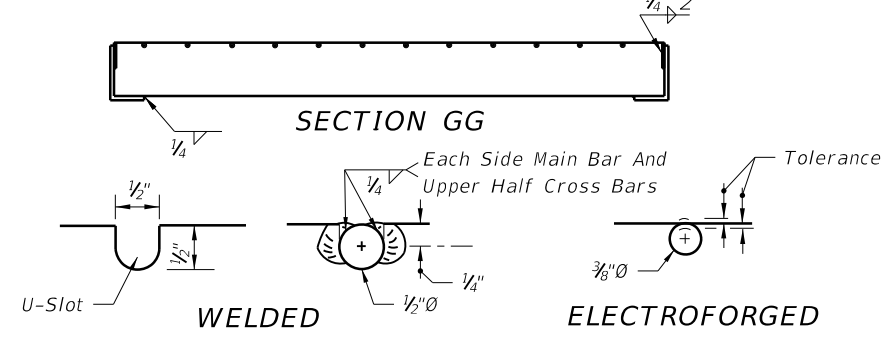

CROSS BAR OPTIONS STEEL GRATE

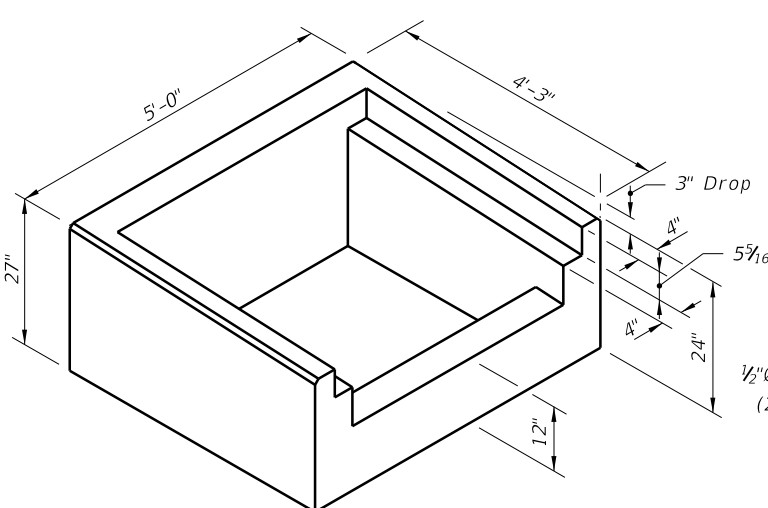

PICTORIAL VIEW OF INLET COLLAR

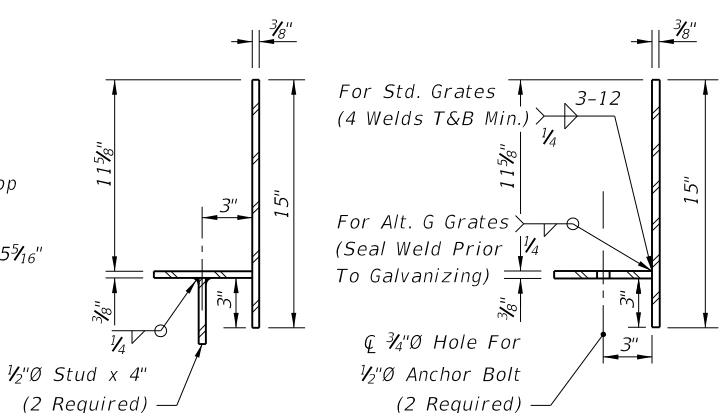

TRANSVERSE SECTIONS THRU BACKWALL PLATE

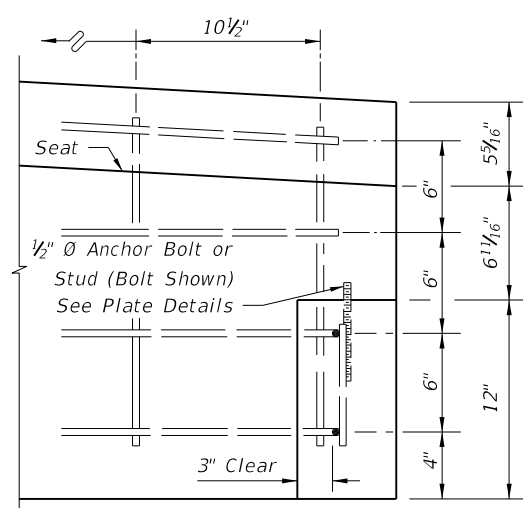

INSET A

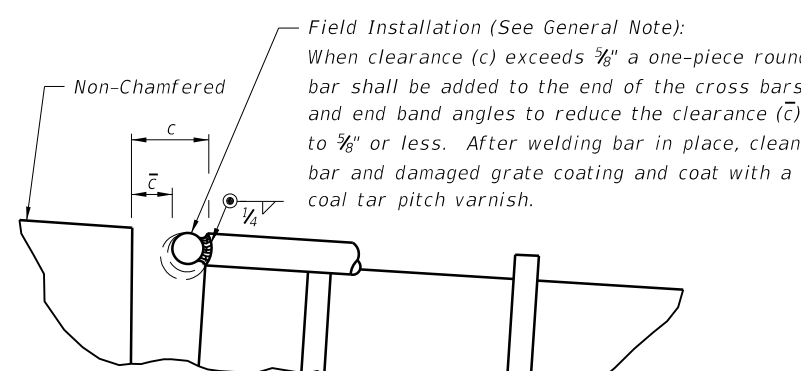

INSET B

NOTES

- All bars #4.
- Anchor bolts shall be either ASTM A307 hex head bolts cast-in-place, or ASTM A36 or F1554 (Grade 36) galvanized fully threaded rod, adhesive bonded anchors installed in accordance with Specification Section 416. Bolts or rods shall be 6" long (4" min. embedment) with one heavy hex head nut (ASTM 194 or A563) and one flat washer (ASTM F436) each. All anchor bolts, nuts and washers shall be hot-dip galvanized.

LAST REVISION	REVISION	DESCRIPTION:	FDOT DESIGN STANDARDS 2013	BARRIER WALL INLET	INDEX NO.	SHEET NO.
07/07/09					218	2