

C:\projects\standards\structures\current\ready\4\release\2012\book_draft\21803-1of3.dgn
 11:51:52 AM
 r0960rh
 12/30/2011

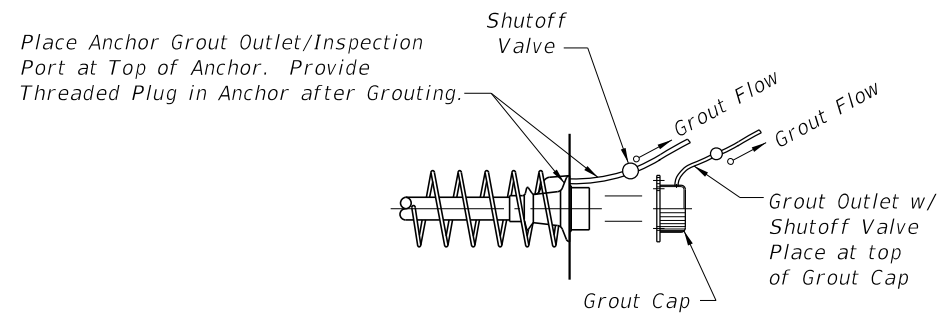

FACE INSPECTED ANCHOR WITH GROUT OUTLET

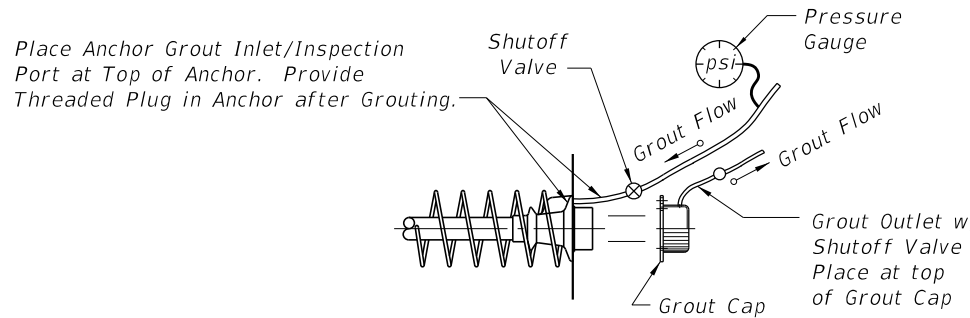

FACE INSPECTED ANCHOR WITH GROUT INLET

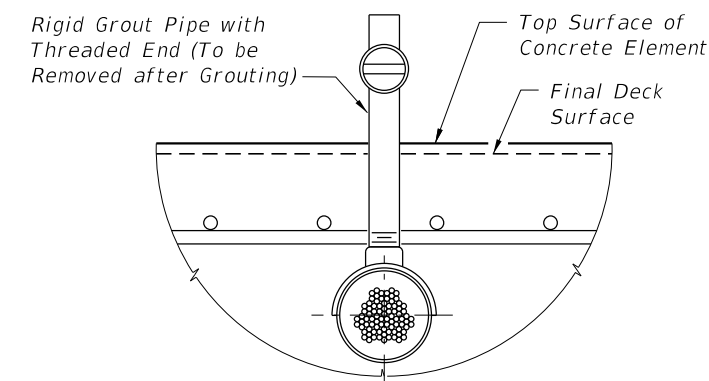

1 GROUT OUTLET CONNECTION TO TENDON

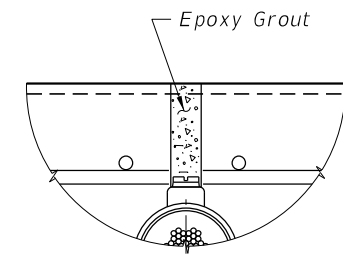

3 FILLING POCKET

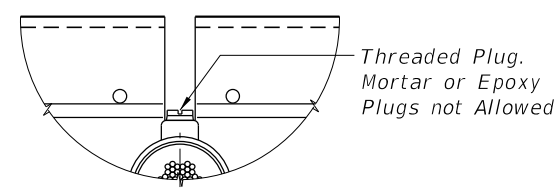

2 POCKET PREPARATION

- PROCEDURE:**
1. Remove Rigid Grout Pipe.
 2. Inspect Tendon for Voids as Necessary.
 3. Vacuum Grout as Required and Allow Grout to Cure. Remove Pipe used for Vacuum Grouting.
 4. Clean Threads and Rethread as Required.
 5. Install Threaded Plug into Outlet to Form a Tight Fit.
 6. Over-Ream Hole (1/4" Ø Over-Ream) Clean and Roughen Sides.
 7. Fill Pocket with Epoxy Grout.

GROUT OUTLET DETAIL AT HORIZONTAL SURFACES

Oversize Rigid Pipe with Temporary Cap Protection (Align with Opening in Grout Cap)

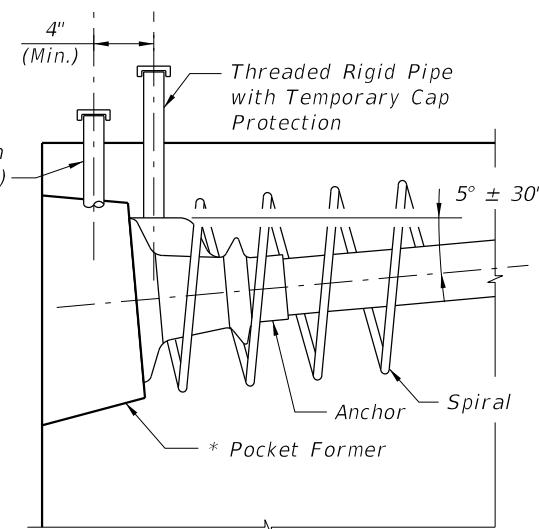

1 INSTALLATION & SHIPPING

Thread Grout Outlet with Grout Valve through Oversize Pipe and into Grout Cap

psi Pressure Gauge

Thread Grout Pipe with Grout Valve and Pressure Gauge into Existing Pipe

4" (Min.)

Threaded Anchor Inlet/Outlet to be offset by 5° to allow vertical anchor inspection.

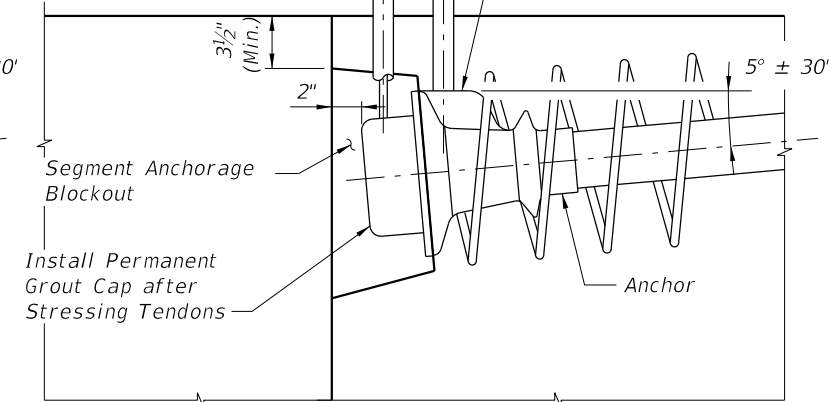

2 GROUTING

Remove and Clean as Per Grout Outlet Detail at Horizontal Surfaces

Inspect Anchor for Voids through Grout Inlet/Outlet. (See Grout Outlet Detail at Horizontal Surfaces for Procedures)

Install Threaded Plug after Inspection of Voids

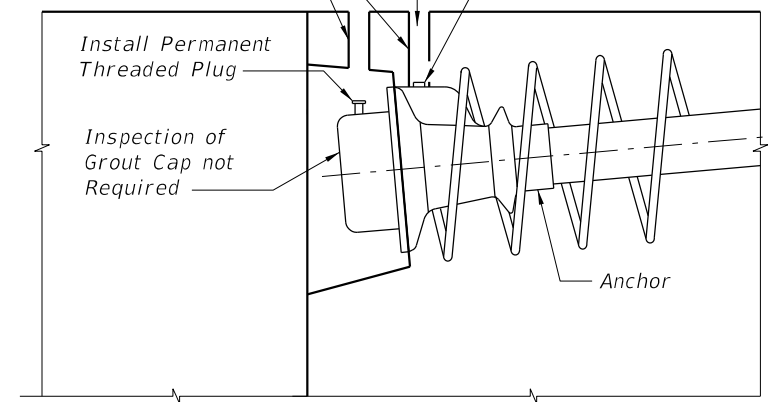

3 INSPECTION

Pour Epoxy Grout into Pipe Recesses

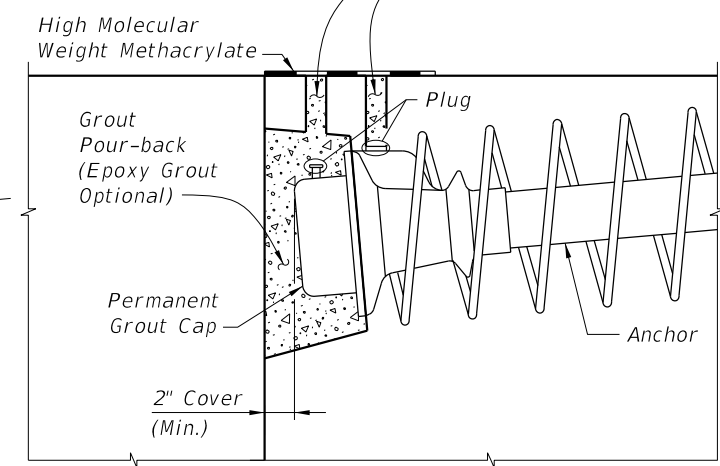

4 PROTECTION

NOTES:

1. Holes used for the Inspection and Grout Inlets/Outlets may be Formed using Tapered Pipes or Mandrels.

TOP INSPECTED ANCHOR WITH GROUT INLET INSTALLATION, GROUTING, INSPECTION & PROTECTION

- * Round ○ Pocket Former - Gravity Fed Placement of Grout Acceptable
- Modified Square ◻ Pocket Former - Gravity Fed Placement of Grout Acceptable
- Square □ Pocket Former - Vacuum Grouting Required

LAST REVISION	DESCRIPTION:	FDOT DESIGN STANDARDS FY 2012/2013	POST-TENSIONING ANCHORAGE AND GROUTING DETAILS	INDEX NO.	SHEET NO.
01/01/11				21803	1

C:\projects\standards\structures\current\ready\4release\2012book_draft\21803-2of3.dgn
 rd960rh
 11:51:53 AM
 12/30/2011

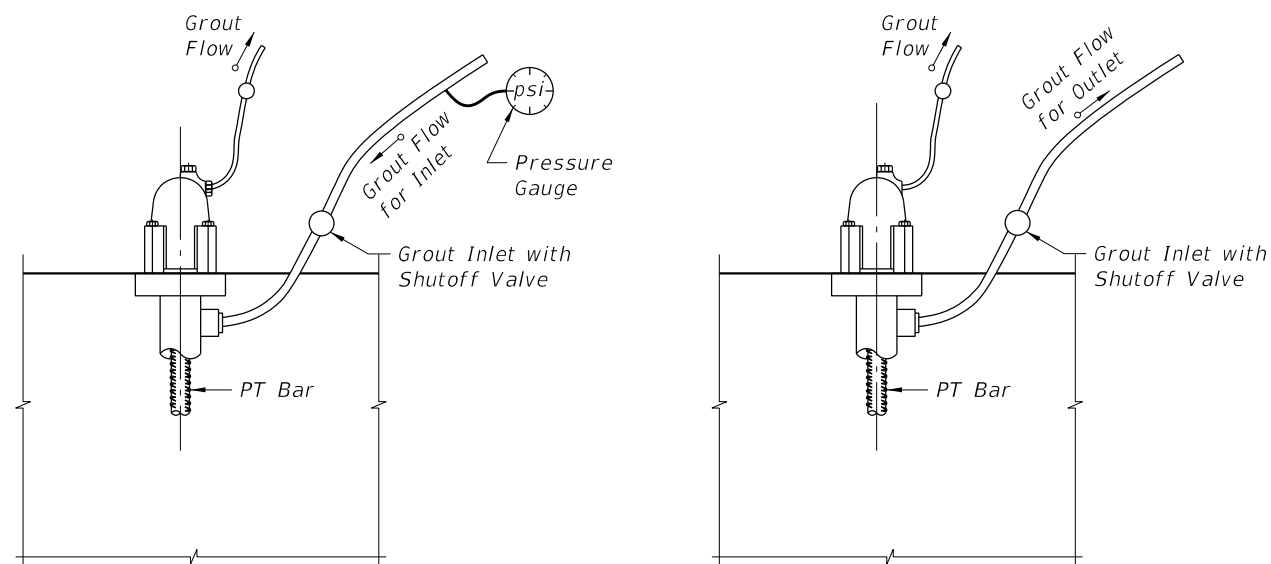

INLET END

OUTLET END

== GROUT INLET AND OUTLET DETAILS FOR PT BARS ==

NOTE:
Anchor or Nut to allow for Flow of Grout into Cap.

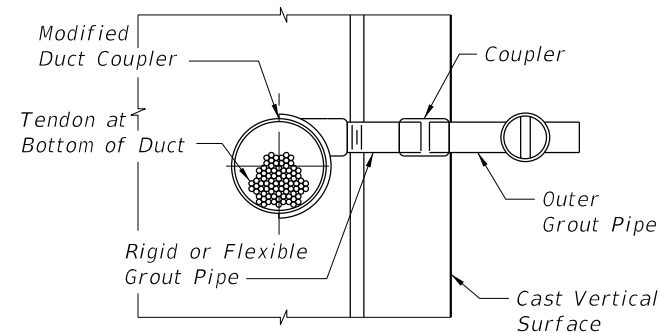

① GROUT OUTLET CONNECTION TO TENDON

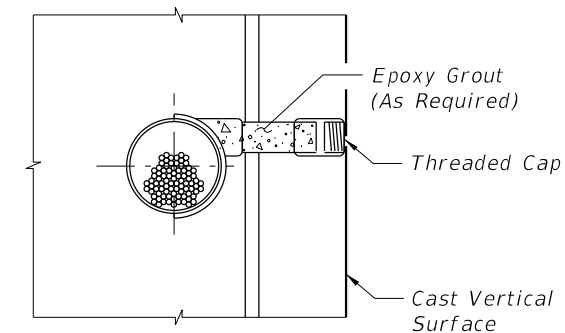

③ FILLING POCKET

PROCEDURE:

1. Remove Rigid Grout Pipe. or Drill Grout in Flexible Pipe.
2. Inspect Tendon for Voids as Necessary.
3. Vacuum Grout as Required and Allow Grout to Cure for 24 hr. (Min.). Remove Pipe used for Vacuum Grouting.
4. Plug Recess with Threaded Cap on Inside Surfaces of Box Sections and Inside (non-fascia) Surfaces of I-Girders. For all other Surfaces, Plug Recess with both Threaded Cap and Epoxy Grout.

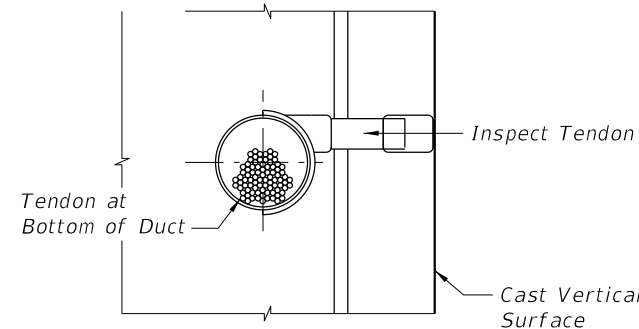

② POCKET PREPARATION

== GROUT OUTLET DETAIL AT VERTICAL SURFACES ==

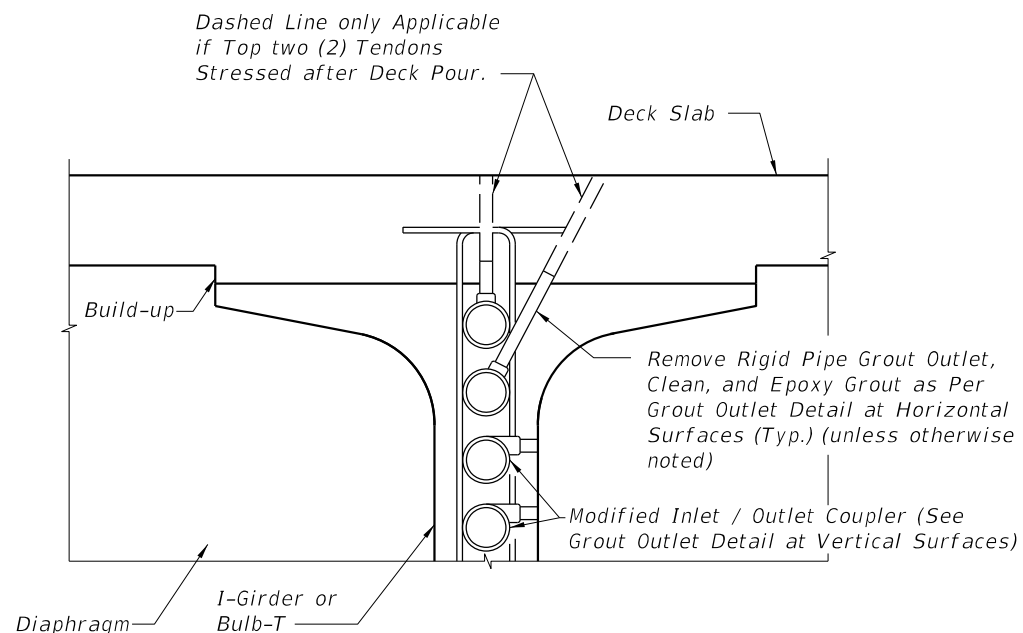

HIGH POINT INSPECTION
LOCATION AT GROUT OUTLET

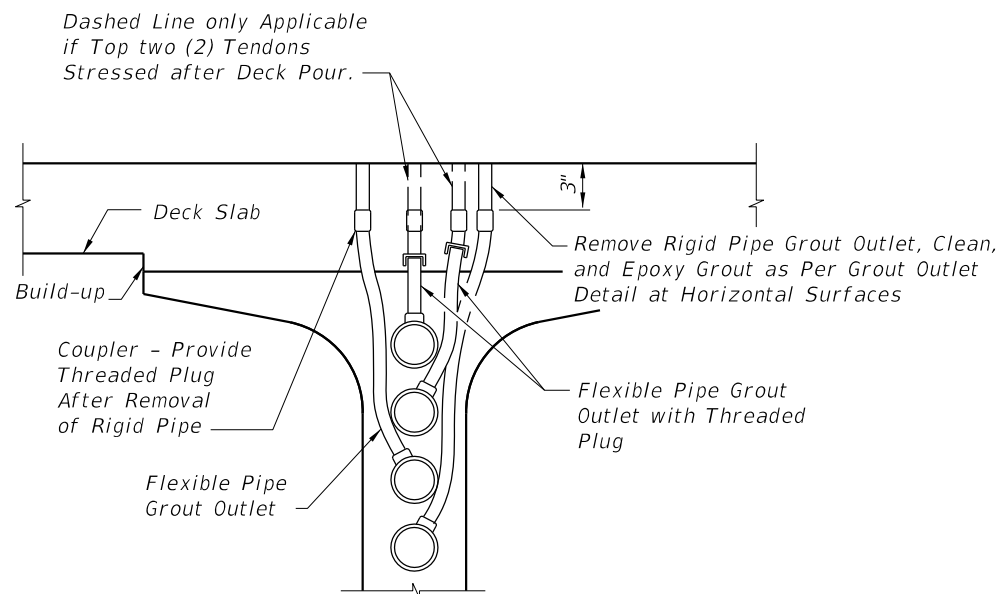

TENDONS AT 3' TO 6'
FROM HIGH POINTS (GROUT OUTLET)

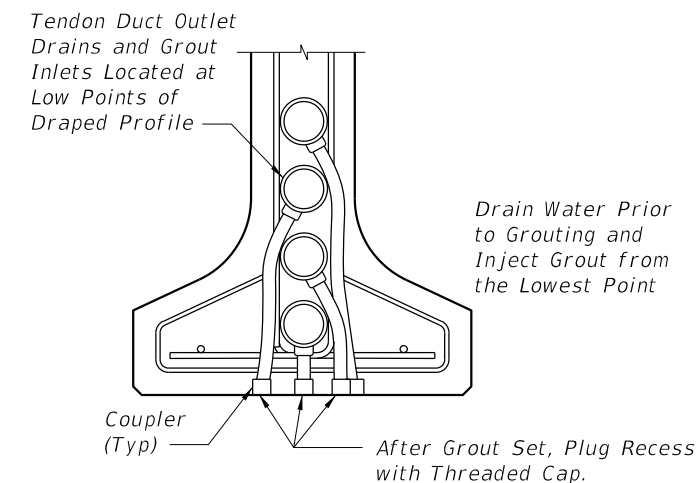

TENDONS AT LOW POINTS
(GROUT INLET / DRAIN)

== GROUT INLET AND OUTLET DETAILS FOR I-GIRDERS/BULB-T'S ==
 Details for C-I-P Boxes with Internal Tendons Similar. Web Reinforcing not Shown for Clarity.

LAST REVISION	DESCRIPTION:
01/01/11	

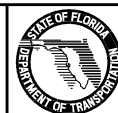

FDOT DESIGN STANDARDS
FY 2012/2013

POST-TENSIONING ANCHORAGE
AND GROUTING DETAILS

INDEX NO.	SHEET NO.
21803	2

C:\projects\standards\structures\current\ready\4release\2012book_draft\21803-3of3.dgn
 rd960rh
 11:51:54 AM
 12/30/2011

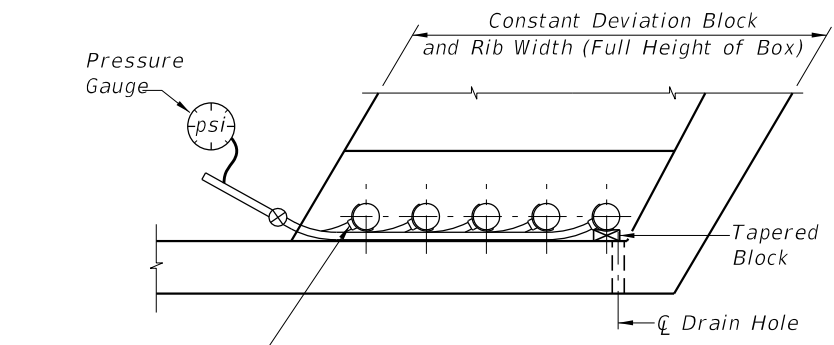

NOTES:
 Place Tapered Blocks Under Each Tendon to be Grouted to Raise Duct off Tendon Strands.
 Center Strands within Duct before Grouting.
 Blocks Shall be Removed after Grout has Set.
 Blocks Shall not Damage or Permanently Deform Duct.

ELEVATION OF GROUT INLET

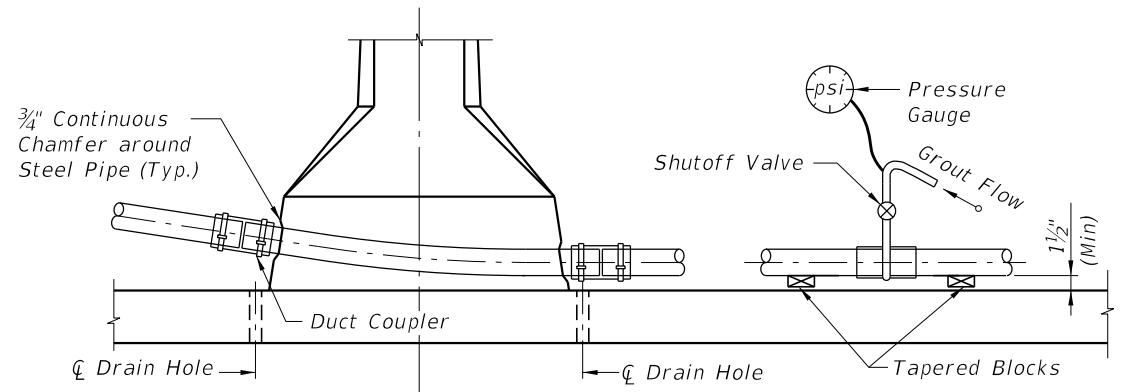

SECTION
GROUTING FOR SPAN BY SPAN CONSTRUCTION

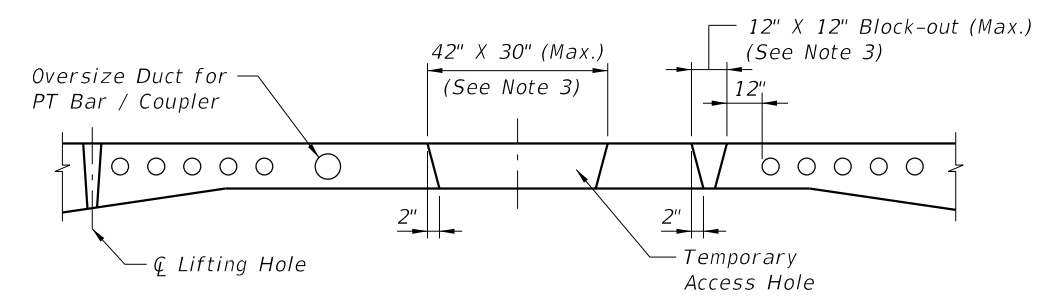

TEMPORARY ACCESS HOLES

- Notes: Temporary Access Holes**
1. Temporary access holes to facilitate access for erection, jacking and grouting operations inside the box during construction are allowed. The access holes shall be limited to a maximum size of 42" wide x 30" long and shall be limited to one per span.
 2. Slab block-outs for temporary / permanent longitudinal post-tensioning bars are not allowed. Temporary / permanent PT bars in the top slab shall be placed in oversized ducts in the slab to accommodate both the bar and coupler.
 3. In lieu of 1 ~ 42" x 30" temporary access hole, a maximum of 2 top slab block-outs (12" x 12" (Max.)) between the webs is allowed for construction per span. Block-outs shall be a minimum of 12" from the nearest duct or anchor and shall be located as to prevent direct drip onto bottom slab anchors.

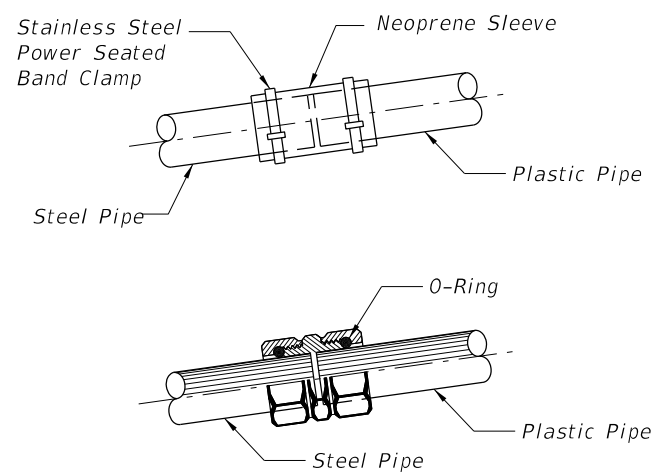

DUCT COUPLER DETAIL

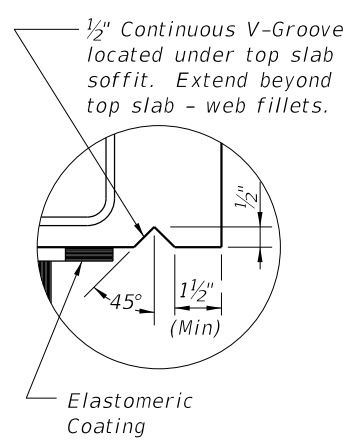

DETAIL OF DRIP LEDGE AT ABUTMENTS AND EXPANSION JOINTS FOR SEGMENTAL AND CAST-IN-PLACE BOX CONSTRUCTION

- Notes: Repair of Temporary Access Holes, Block-outs, and Lifting Holes**
1. Form all large block-outs with tapered sides.
 2. Immediately before casting the concrete, mechanically clean the mating concrete surfaces to remove any laitance and to expose small aggregate.
 3. Repair all holes and block-outs with Magnesium Ammonium Phosphate Concrete within 24 hours of cleaning concrete.
 4. After completion of the deck grooving, coat the repaired and surrounding concrete surfaces with High Molecular Weight Methacrylate.
 5. Alternately, epoxy grout may be used to repair holes. High Molecular Weight Methacrylate is not required with epoxy grout.

LAST REVISION	REVISION	DESCRIPTION:	 FDOT DESIGN STANDARDS FY 2012/2013	POST-TENSIONING ANCHORAGE AND GROUTING DETAILS	INDEX NO. 21803	SHEET NO. 3
01/01/11						