

* These dimensions are measured perpendicular to the end of beam

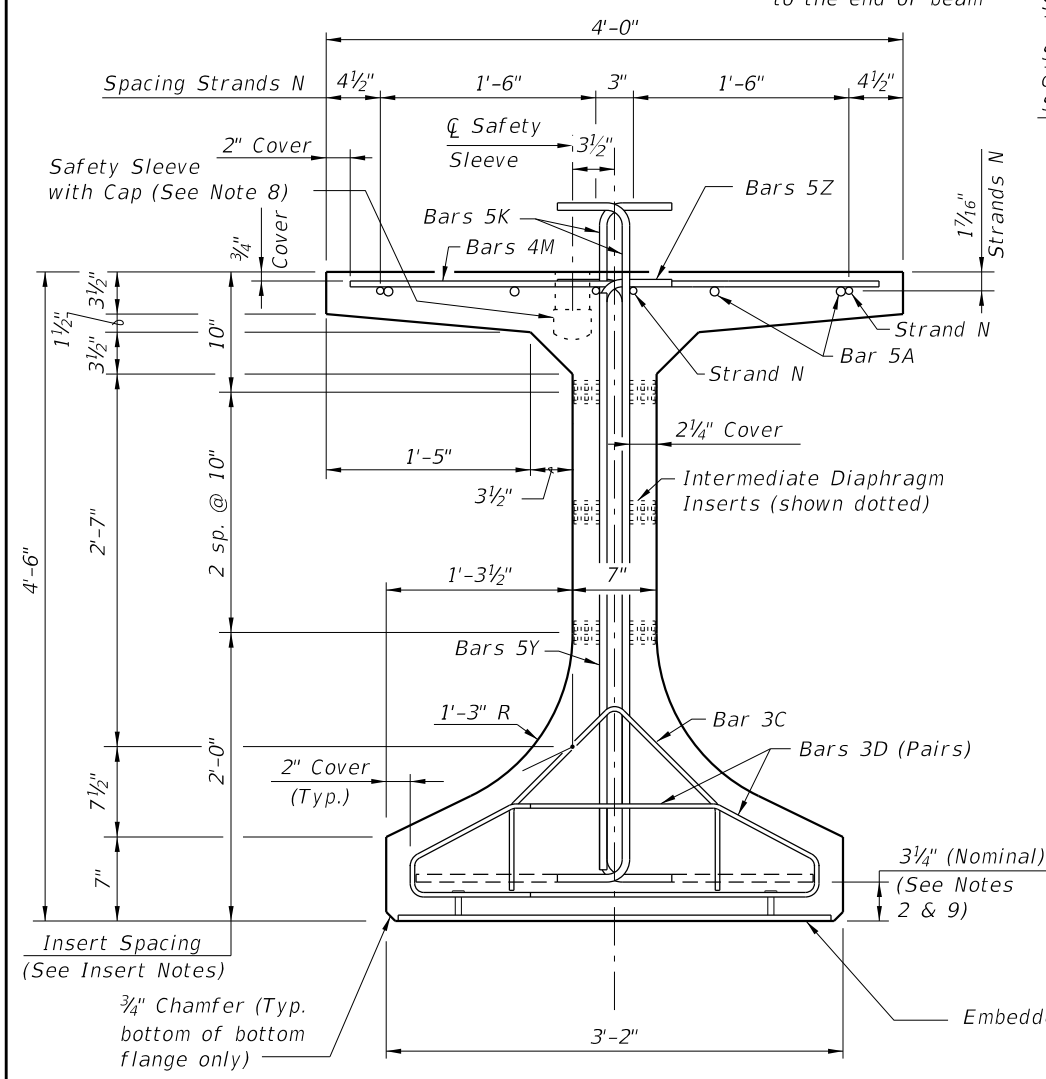

END VIEW

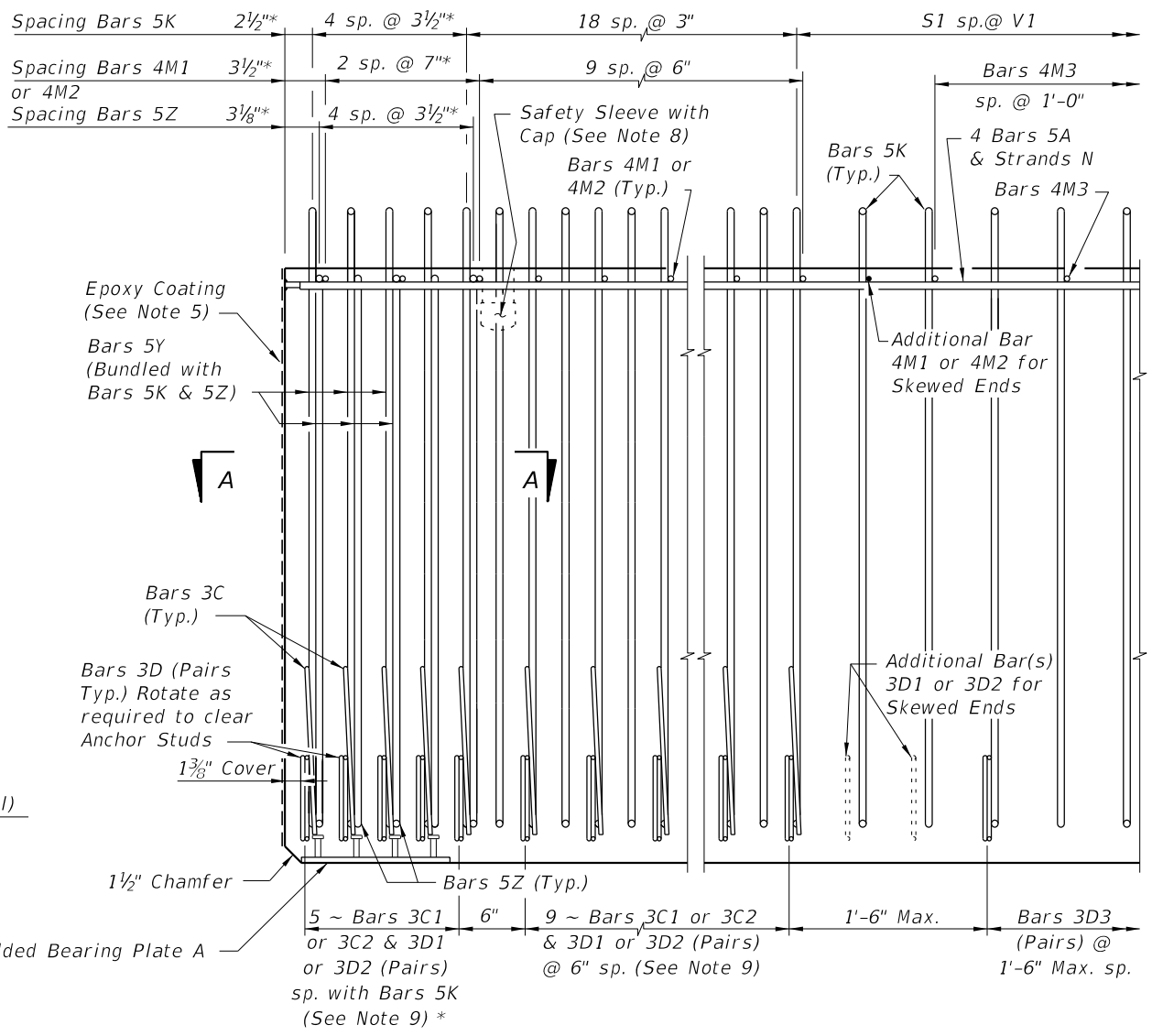

ELEVATION AT END OF BEAM
(Flanges Not Shown For Clarity)
(End 1 Shown, End 2 Similar)

| CONVENTIONAL REINFORCING BAR BENDING DETAILS | | | | |
|--|----------------|---------------|-----------------|-----------------|
| BILL OF REINFORCING STEEL | | | | |
| MARK | NOTE NUMBERS | SIZE | NUMBER REQUIRED | LENGTH (NOTE 1) |
| A | — | 5 | 8 | 22'-0" |
| C1 | 9, 10 & 11 | 3 | 14 (End 1) | Varies |
| C2 | 9, 10 & 11 | 3 | 14 (End 2) | Varies |
| D1 | 9, 10, 11 & 14 | 3 | 28 (End 1) | Varies |
| D2 | 9, 10, 11 & 14 | 3 | 28 (End 2) | Varies |
| D3 | 9 & 14 | 3 | See Table | 4'-3" |
| K | 2, 9, 11 & 13 | 5 | See Table | 5'-8" |
| M1 | 9 & 10 | 4 | 12 (End 1) | Varies |
| M2 | 9 & 10 | 4 | 12 (End 2) | Varies |
| M3 | 9 | 4 | See Table | 3'-8" |
| N | 3 & 4 | 3/8" Ø Strand | 4 | Dim. L |
| Y | 9 & 11 | 5 | 12 | 4'-0" |
| Z | 2, 9, 11 & 13 | 5 | 10 | 5'-2" |

BENDING DIAGRAMS (See Note 1)

NOTES:
 A. Work this Index with Index No. 20010 - Typical Florida-I Beam Details and Notes and the Florida-I Beam - Table of Beam Variables in Structures Plans.
 B. For referenced notes, see Index No. 20010.
 C. For Dimensions A, B, C, D, L, R & V1 and number of spaces S1 thru S4, see Florida-I Beam - Table of Beam Variables in Structures Plans.

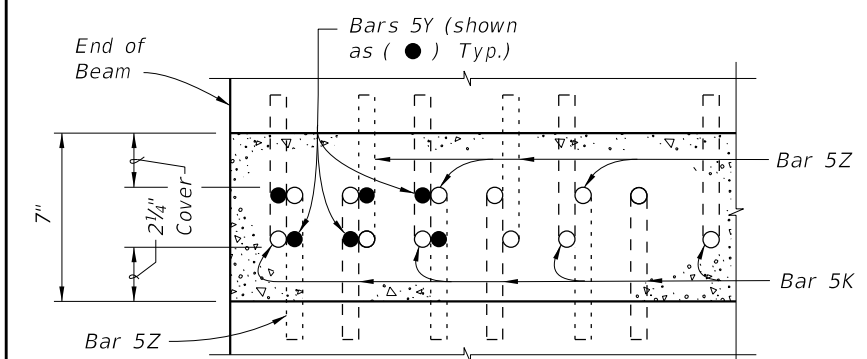

SECTION A-A FOR CONVENTIONAL REINFORCING
(Showing Bars 5K, 5Y & 5Z Only)

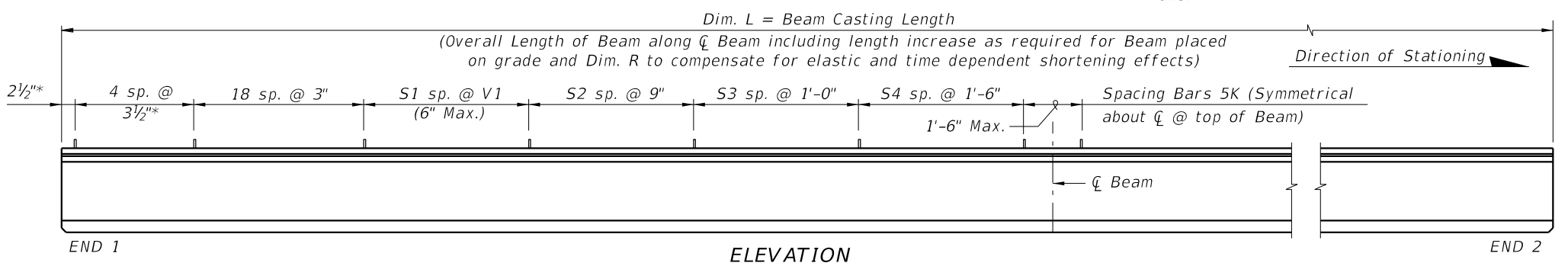

END 1

ELEVATION

END 2

12/30/2011 11:50:21 AM r0960rh C:\projects\standards\structures\current\ready\4release_2012\book_draft\20054-1of2.dgn

ALTERNATE REINFORCING STEEL (WELDED WIRE REINFORCEMENT) DETAILS

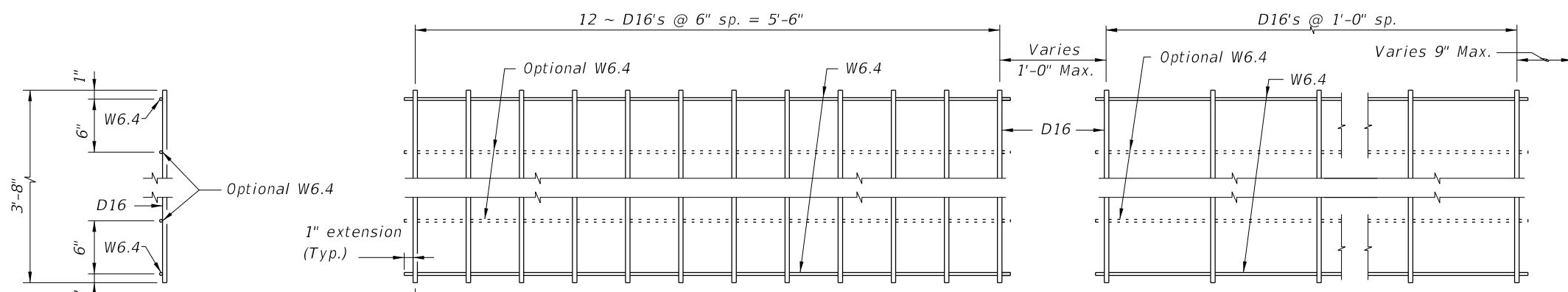

PLAN VIEW
PIECE M-1
(2 Required)

PLAN VIEW
PIECE M-3
(2 Required)

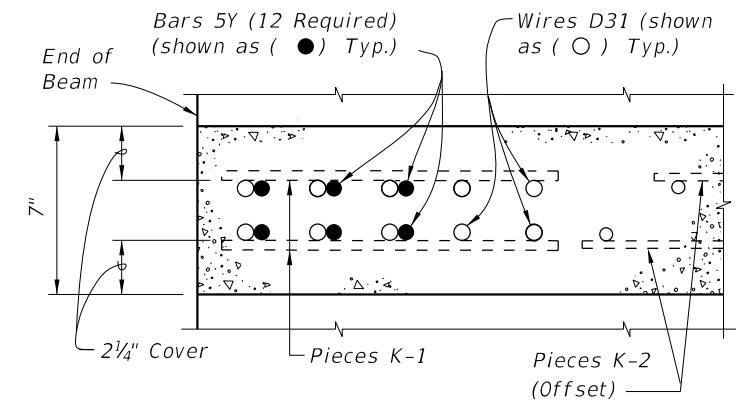

SECTION A-A
FOR WELDED WIRE REINFORCEMENT

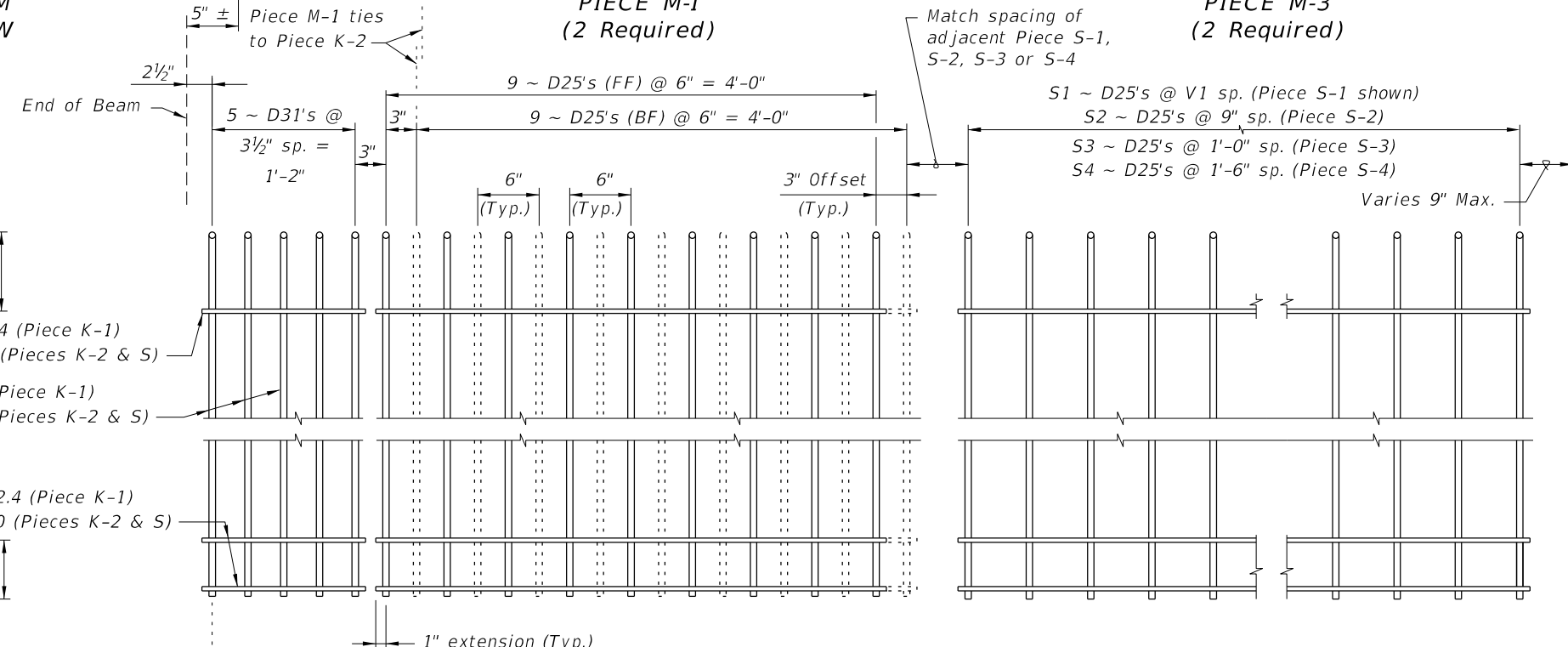

PIECE K-1
(Aligned EF)
(4 Required ~ 2 Pairs)

PIECE K-2
(FF Shown Solid, BF Shown Dashed)
(4 Required)

PIECE S-1, S-2, S-3 or S-4
(2 Required Each Piece)

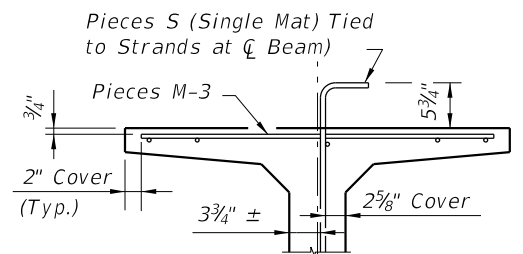

PARTIAL SECTION AT CENTER BEAM

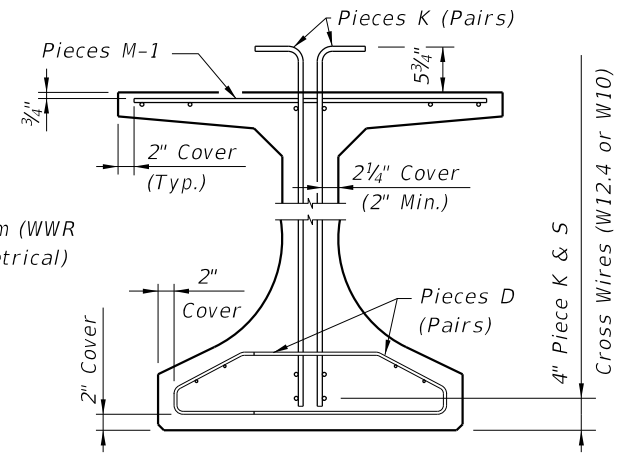

PARTIAL BEAM END VIEW
(Conventional Reinforcing Bars A, C, Y and Strands not Shown for Clarity)

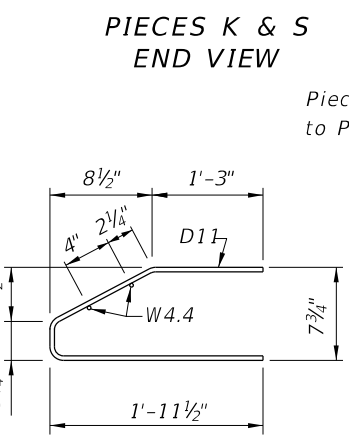

PIECES D
END VIEW

PIECE D-1
(4 Required ~ 2 Pairs)

PIECE D-2
(4 Required ~ 2 Pairs)

PIECE D-3
(4 Required ~ 2 Pairs)

LEGEND:
EF = Each Face
FF = Front Face
BF = Back Face

- NOTES:
- See Sheet 1 for placement details & Table of Beam Variables in Structures Plans for variables S1, S2, S3, S4 & V1.
 - Place Conventional Reinforcement Bars 5A & 3C as shown on Sheet 1. Place additional Bars 5Y as shown in Section A-A for Welded Wire Reinforcement. Bars 5Z will not be used with the WWR Option.
 - Pieces may be fabricated in multiple length sections.
 - For beams with skewed end conditions, Pieces D-1, D-2 & M-1 shall not be used; Conventional Reinforcement Bars D1, D2, C1, C2, M1 & M2 shall be used. See Index No. 20010 Skew Details and Note 9 for placement details. Shift Pieces K & Bars 5Y to accommodate skewed end conditions and align with Bars C and D.

12/30/2011 11:50:22 AM rd960r/h C:\projects\standards\structures\current\ready\4release\2012book_draft\20054-2of2.dgn

| | | | | | | | |
|---------------------------|--------------|--|---------------------------------------|--------------------------------------|--|--------------------|----------------|
| LAST REVISION 07/01/10 | DESCRIPTION: | | FDOT DESIGN STANDARDS FY 2012/2013 | FLORIDA-I 54 BEAM - STANDARD DETAILS | | INDEX NO. 20054 | SHEET NO. 2 |
| REVISION | | | | | | | |