

12/30/2011 11:49:17 AM r4960/h C:\projects\standards\roadway\17700-s\17721-01.dgn

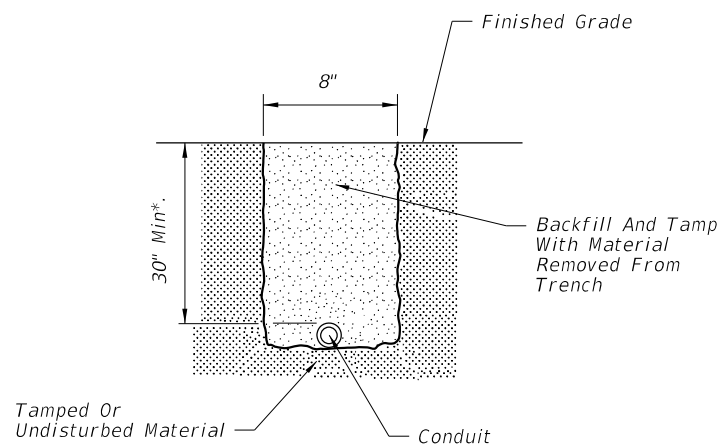

FOR USE IN AREAS NOT EXPOSED TO VEHICULAR TRAFFIC

FIGURE A

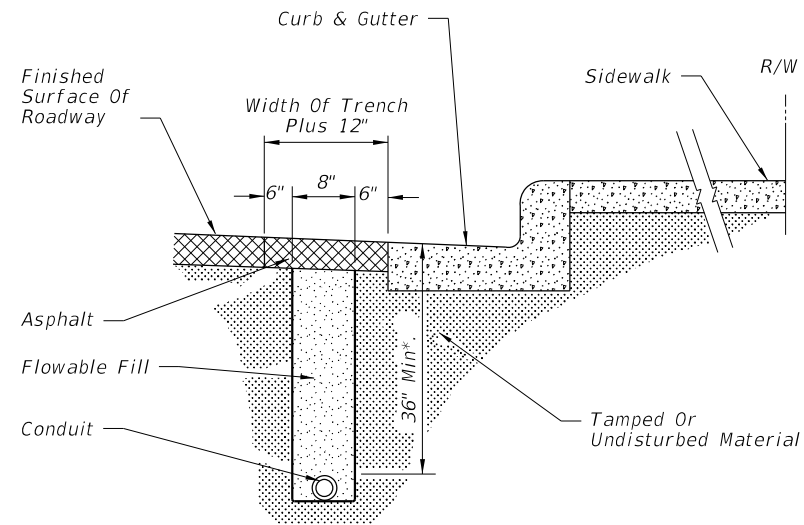

FOR USE IN ASPHALT ROADWAY ADJACENT TO GUTTER WHEN PLACEMENT OUTSIDE OF THE PAVEMENT IS NOT FEASIBLE.

FIGURE B

- Note:
1. Trench not to be open more than 250' at a time when construction area is subject to vehicular or pedestrian traffic.
 2. Asphalt to be sawcut to leave neat lines at the pavement cut.
 3. See note 3 Figure C.

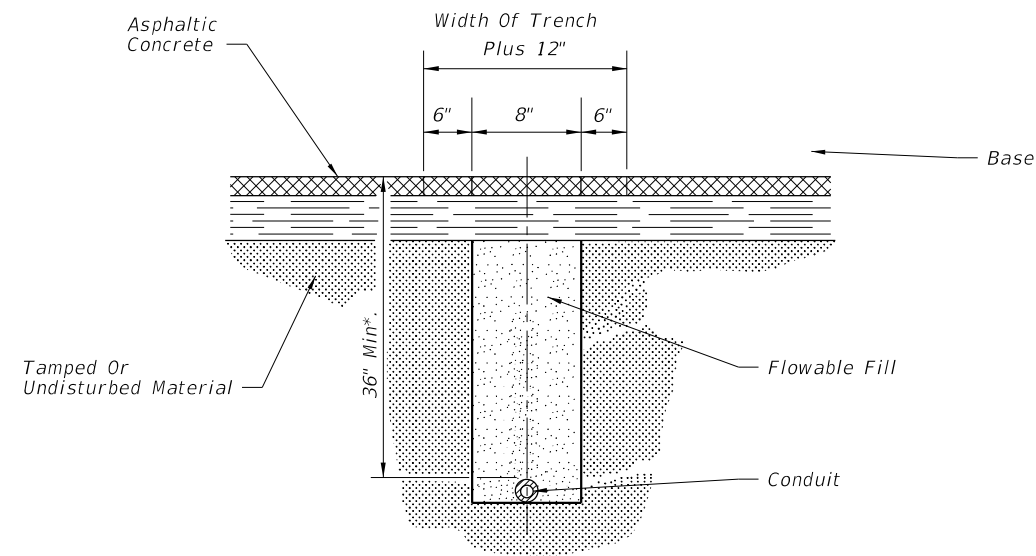

FOR USE IN INSTALLING CONDUIT UNDER EXISTING ASPHALT PAVEMENT NOT ADJACENT TO GUTTER WHEN JACKING OR DIRECT BORING IS NOT FEASIBLE.

FIGURE C

- Note:
1. Rigid conduit must be used when jacking under existing pavement at 36" minimum depth.
 2. Asphalt to be sawcut at the edges of the trench.
 3. The removal and replacement of the additional pavement width (6") will not be required when the trench can be constructed without disturbing the asphalt surface on either side.

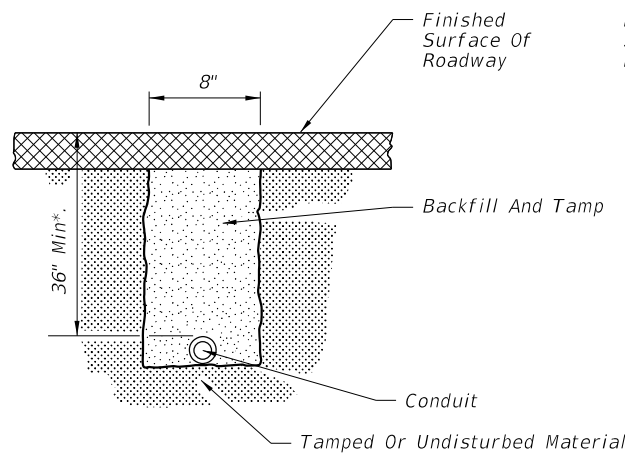

FOR USE INSTALLING CONDUIT UNDER A NEW ROADWAY PRIOR TO INSTALLATION OF BASE AND PAVEMENT

FIGURE D

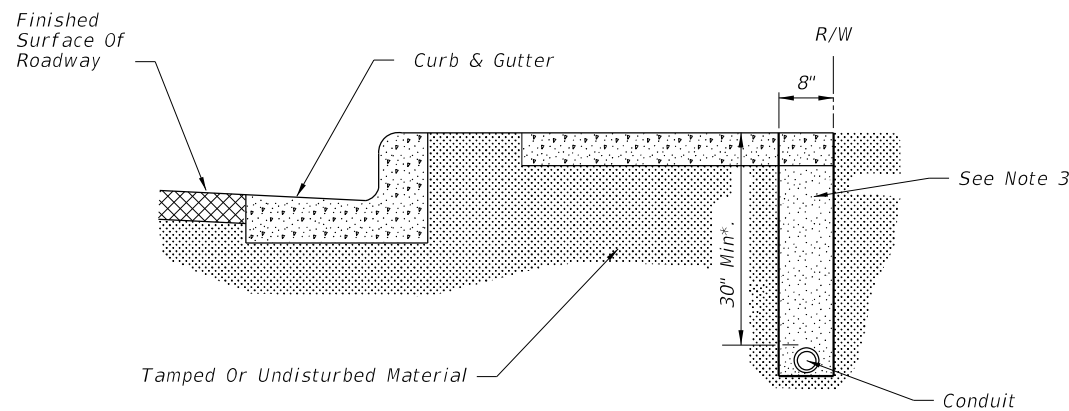

FOR USE IN INSTALLING CONDUIT UNDER SIDEWALK

FIGURE E

- Note:
1. Sidewalk patches to match existing joints.
 2. Entire sidewalk slab must be replaced when specified in the plans.
 3. Backfill and tamp with material from trench except at driveways. At driveways, backfill a length of trench within the driveway entirely with Flowable Fill.

*May be adjusted due to field conditions upon approval of project engineer.

LAST REVISION	REVISION	DESCRIPTION:	 FDOT DESIGN STANDARDS FY 2012/2013	CONDUIT INSTALLATION DETAILS	INDEX NO.	SHEET NO.
01/01/12					17721	1

C:\projects\standards\roadway\17700-s\17721-02.dgn
 r0960/h
 11:49:18 AM
 12/30/2011

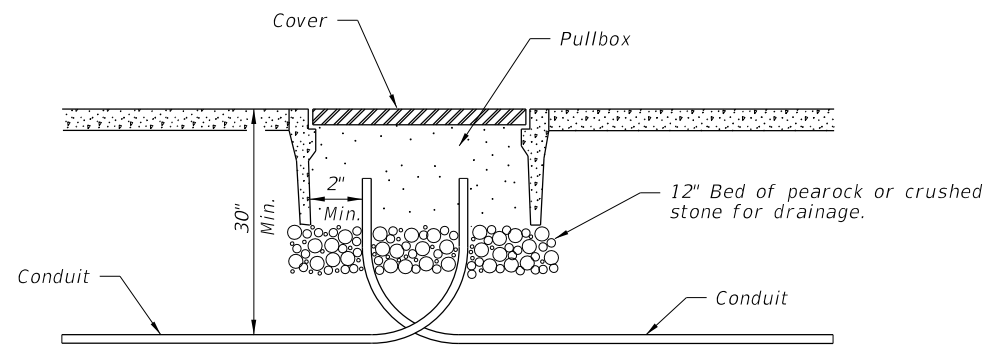

PULLBOX ENTRY OF CONDUIT UNDER SIDEWALKS

FIGURE A

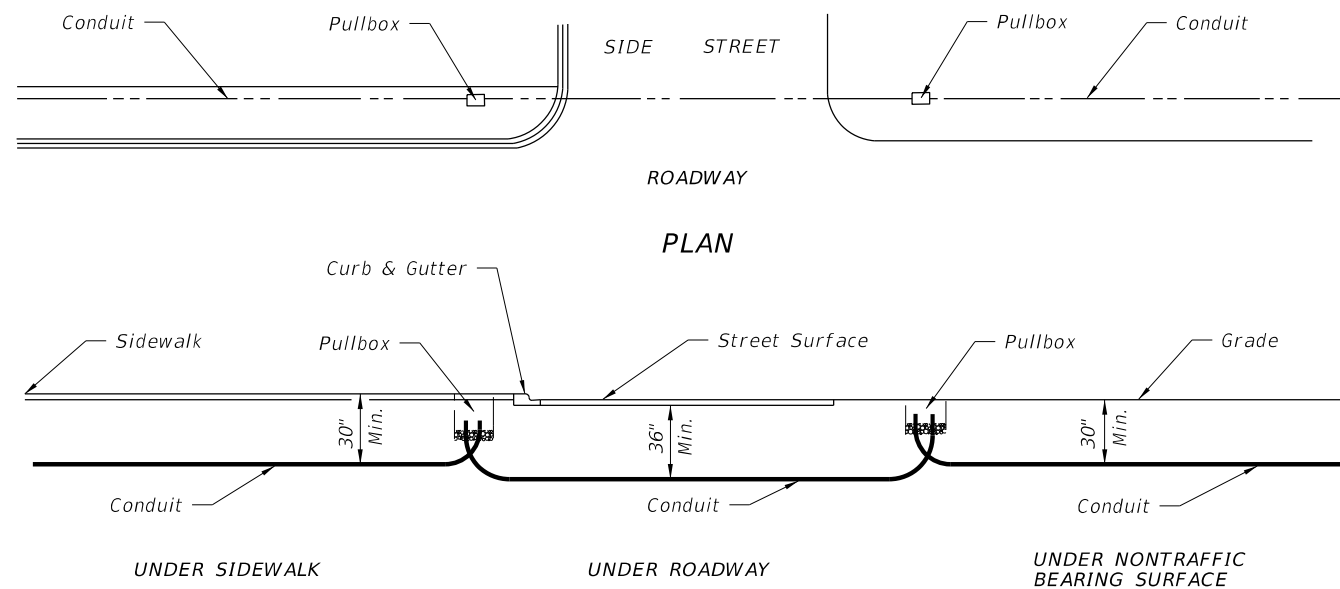

SECTION

FIGURE B

Note:
 Ends of conduit shall be sealed in accordance
 with Section 630 of the Standard Specifications
 for Road and Bridge Construction.

Note:
 One run of conduit (between pullboxes) shall not contain
 more than 360° of bend including pullbox bends.

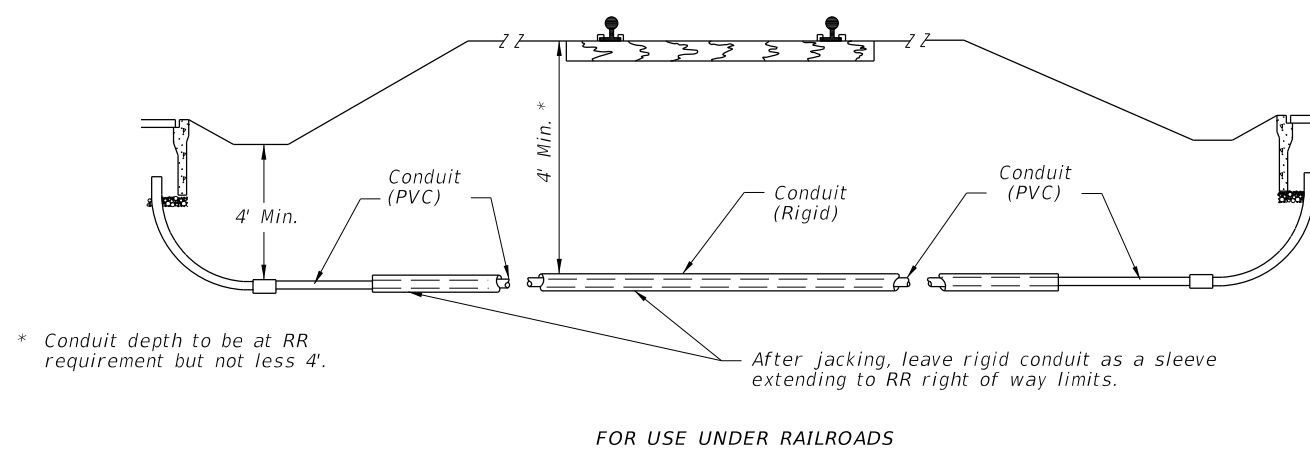

FIGURE C

LAST REVISION	DESCRIPTION:	 FDOT DESIGN STANDARDS FY 2012/2013	CONDUIT INSTALLATION DETAILS		INDEX NO.	SHEET NO.
07/01/00					17721	2