

C:\projects\standards\structures\current\ready\4release\2012book_draft\11870-1of2.dgn
 rd960rh
 11:48:18 AM
 12/30/2011

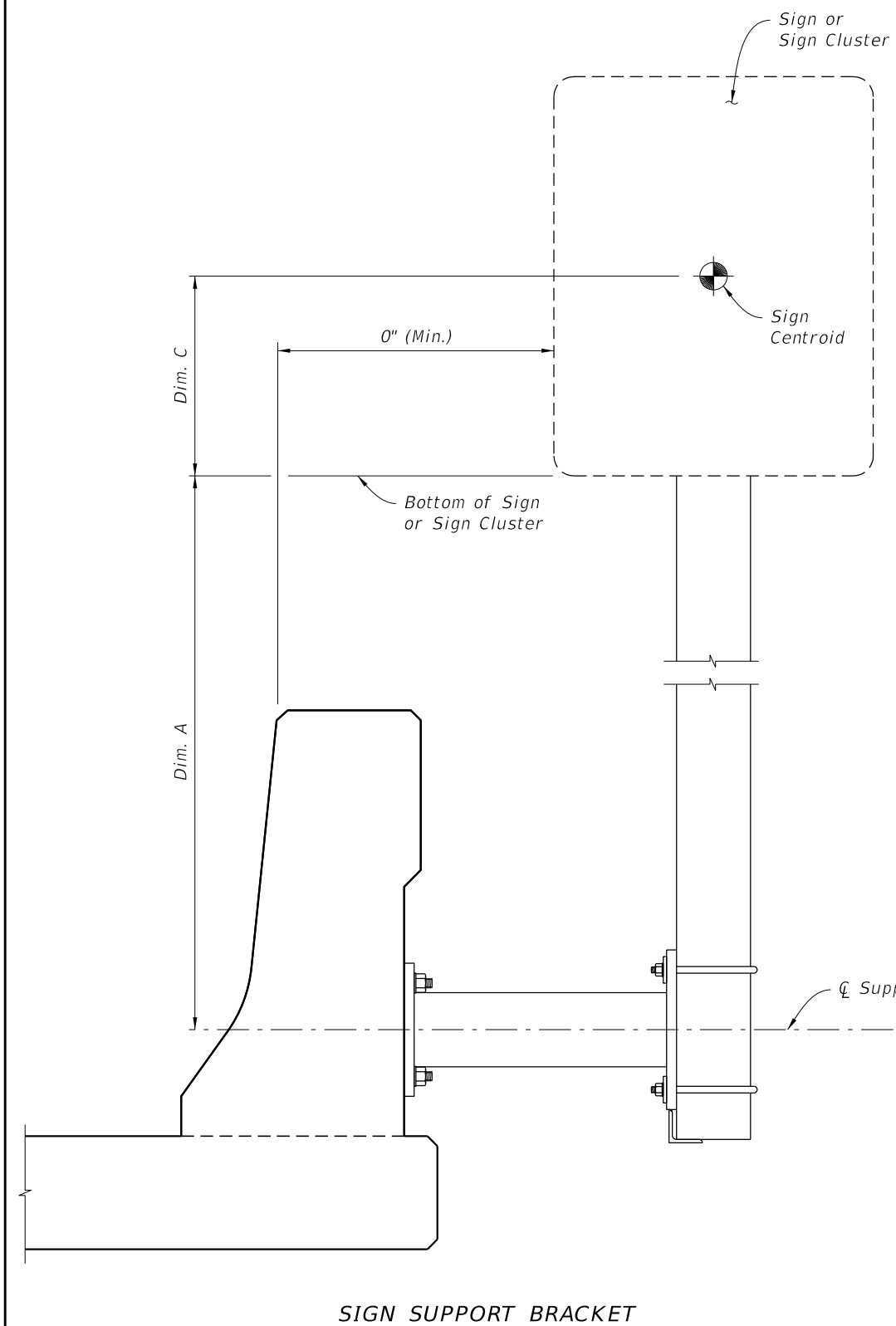

SIGN SUPPORT BRACKET

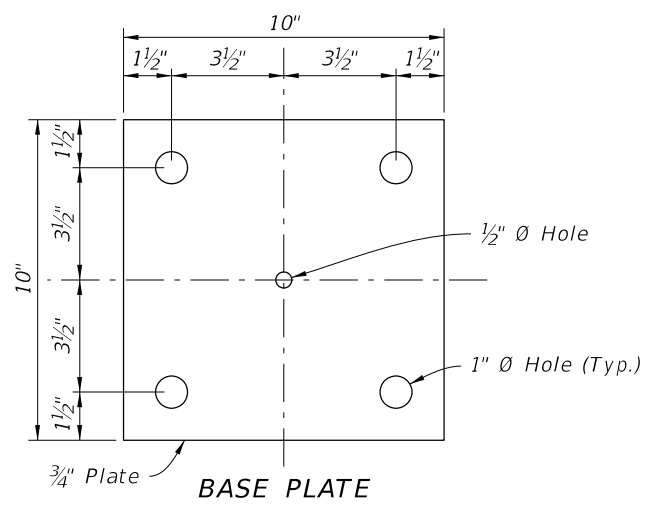

BASE PLATE

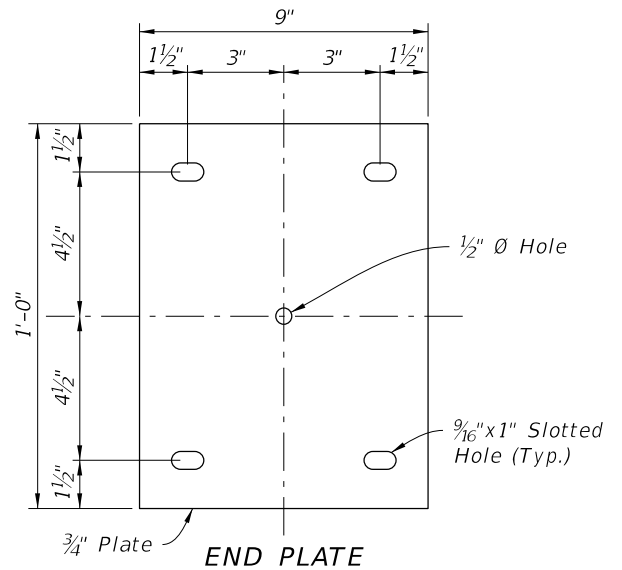

END PLATE

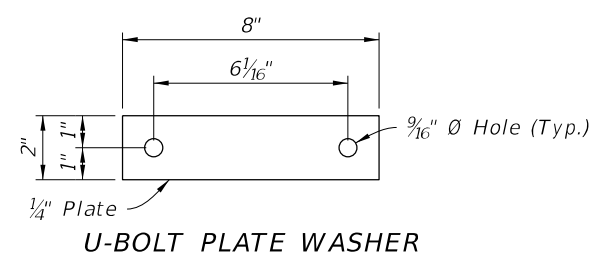

U-BOLT PLATE WASHER

NOTES:

DESIGN SPECIFICATIONS: AASHTO Standard Specifications for Structural Supports for Highway Signs, Luminaires and Traffic Signals as modified by the FDOT Structures Manual.

WIND SPEEDS: See Index 11860 - Wind Speeds by County note.

GEOMETRY: Install signs with bottom edge of the lower sign panel at 7' above the gutter line. Edge of sign panels must not extend beyond the inside face of the top of the traffic railing. Sign posts shall be installed plumb.

APPLICABILITY: Mount only to concrete traffic barriers in locations where ground mounting is not possible. Work this Index in conjunction with Index No. 11860.

SHOP DRAWINGS: Shop drawings are not required.

PAYMENT: Payment for sign support bracket shall be included in the cost of the single post sign.

MATERIALS:

Coatings: All steel and fasteners shall be hot dip galvanized in accordance with Specification Section 962. Sign Support Weldment shall be hot dip galvanized after fabrication. Paint sign support brackets and posts when shown in the plans in accordance with Specification Section 649-4.

Support Posts: ASTM A501 5" NPS Schedule 40 Steel Pipe.

Sign Posts: Aluminum Association Alloy 6061-T6 (ASTM B209, B221 or B308) 5" NPS Schedule 40 Aluminum Pipe.

Steel Plates: ASTM A36 or A709 Grade 36.

Anchor Bolts: ASTM F1554 Grade 55 with a single self-locking hex nut and washers. Install anchor bolts perpendicular to the base plates on back of traffic railing. See Anchor Bolt Notes, Sheet 2 of 2.

Adhesive Bonded Anchors: Fully threaded Anchor Bolts with Type HV Adhesive Bonding Material System in accordance with Specification Section 416 & 937. In lieu of the number of anchors specified to be tested in Specification Section 416-6, field test all adhesive bonded anchors installed per this Design Standard.

U-Bolts: ASTM A449 sized for sign post, with flat washers and locking hex nuts.

Welding: Weld in accordance with American Welding Society Structural Welding Code (Steel), ANSI/AWS D1.1 (current edition). Required weld material is E70XX. Nondestructive testing is not required.

SIGN LIMITATIONS TABLE		
MAX. WIND SPEED (MPH)	MAX. SIGN AREA (SF)	MAX. SIGN CENTROID HEIGHT (DIM. A + DIM. C)
110	30	9'-10"
130	25	9'-7"
150	20	9'-7"

Dim. A = Distance from centerline of the Support Post to the bottom of the sign or sign cluster.

Dim. C = Vertical distance from the bottom of the sign or sign cluster to the Centroid of the sign or sign cluster.

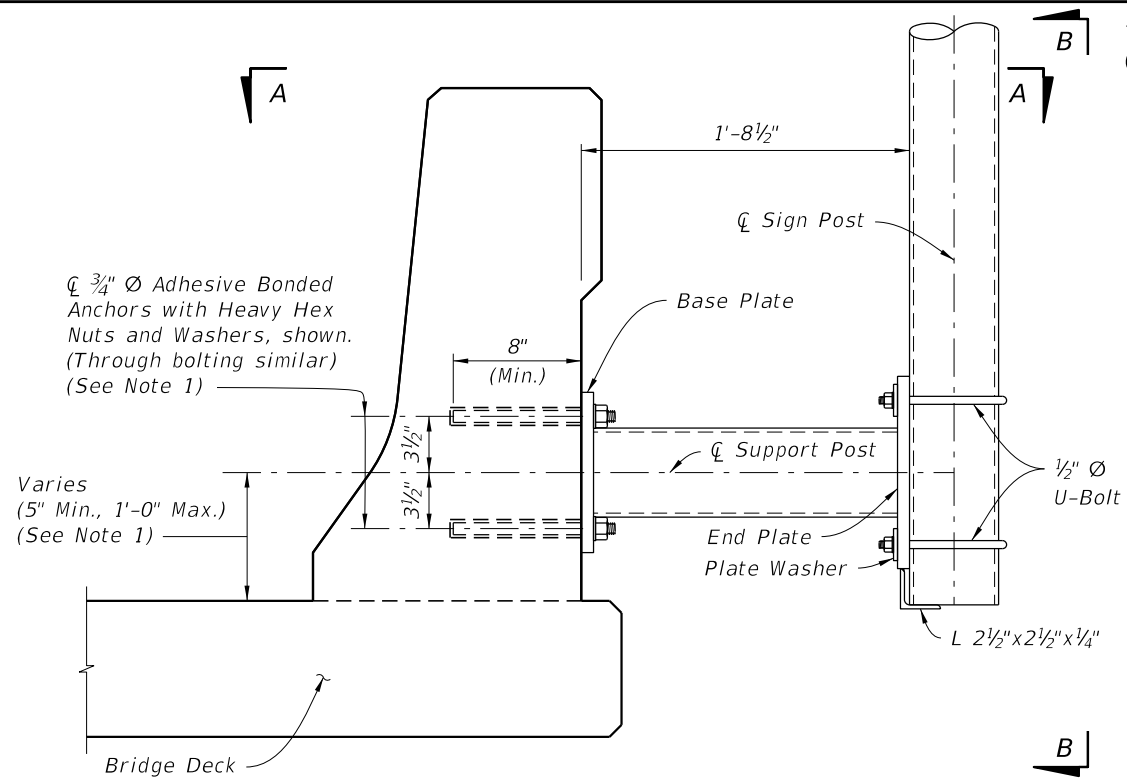

TYPICAL SECTION THRU EXISTING TRAFFIC RAILING AT SIGN SUPPORT BRACKET
(32" F-Shape Traffic Railing shown, other Traffic Railings & Parapet similar)
(Bridge Deck shown, Approach Slab and Retaining Wall Similar)

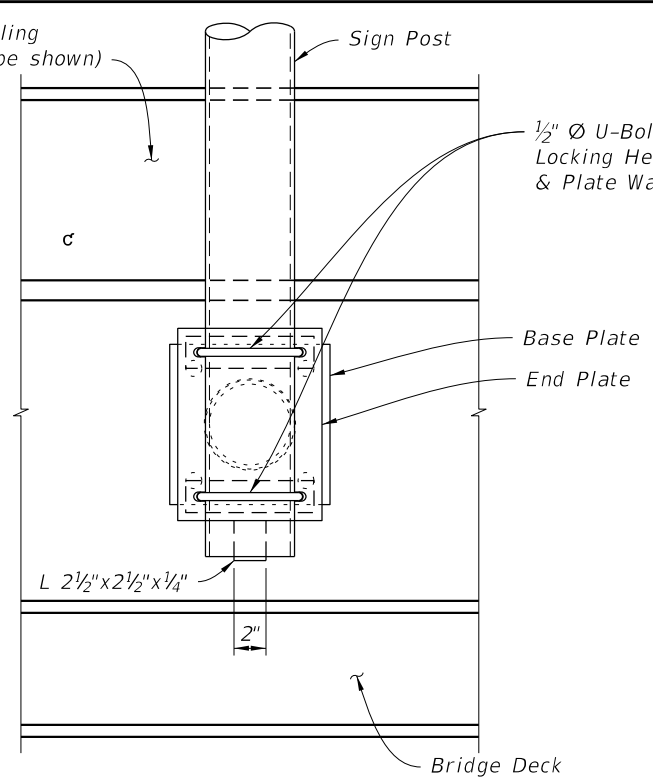

VIEW B-B
SIGN SUPPORT BRACKET

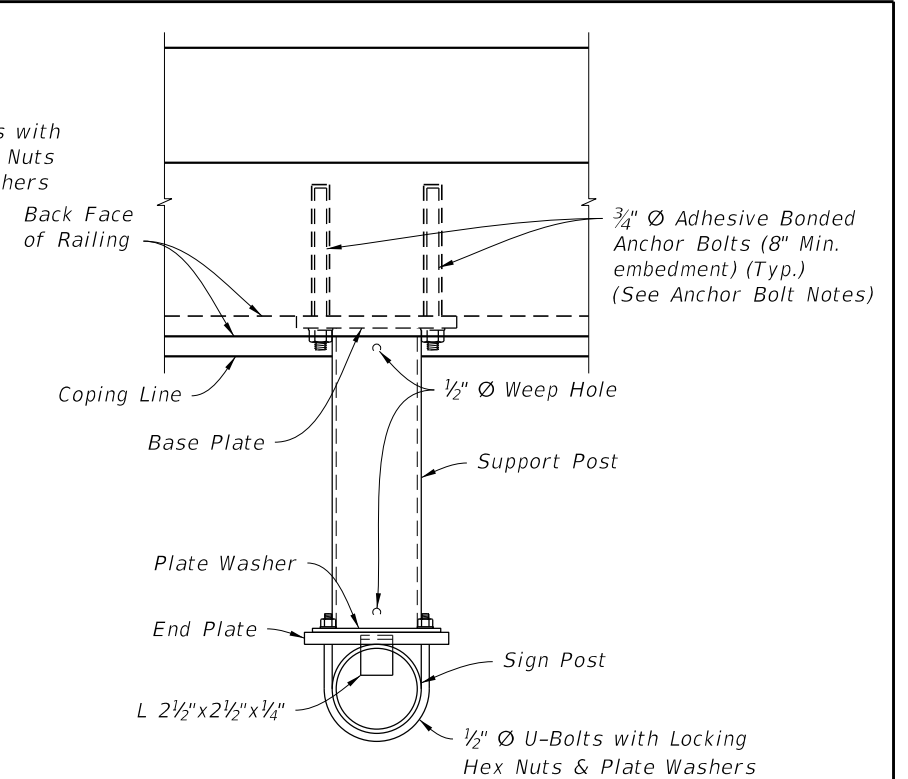

PLAN VIEW A-A
SIGN SUPPORT BRACKET

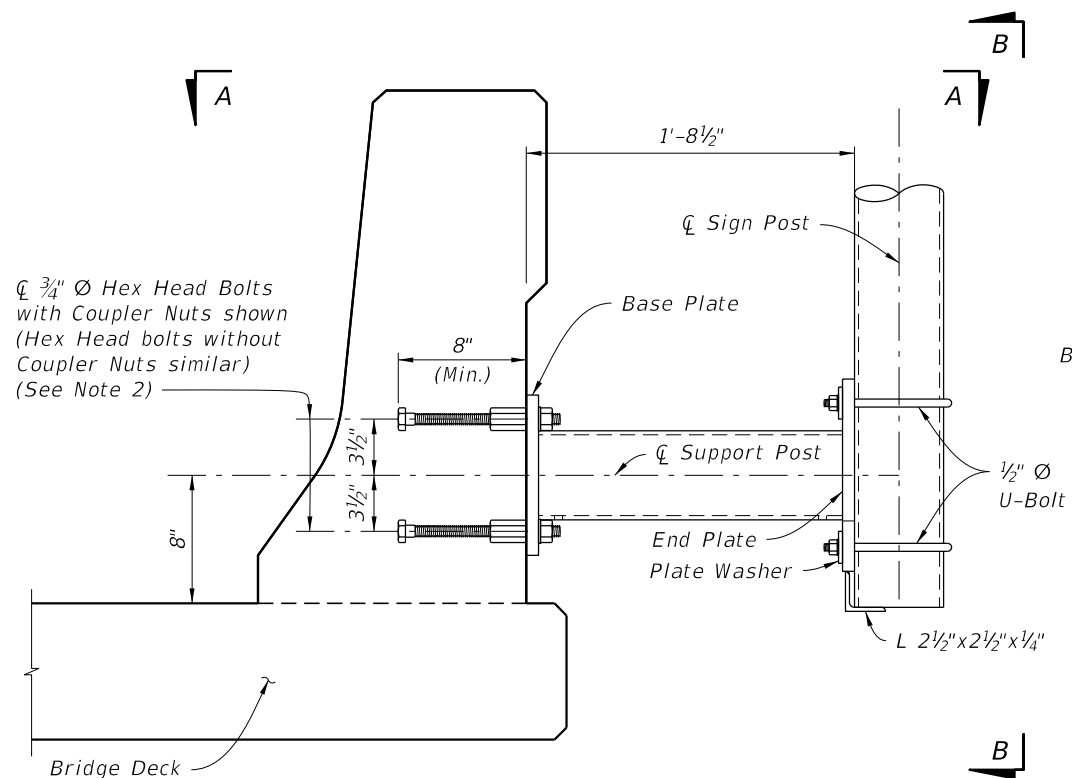

TYPICAL SECTION THRU TRAFFIC RALING AT SIGN SUPPORT BRACKET (NEW CONSTRUCTION)
(32" F-Shape Traffic Railing shown, other Traffic Railings & Parapet similar)
(Bridge Deck shown, Approach Slab and Retaining Wall Similar)

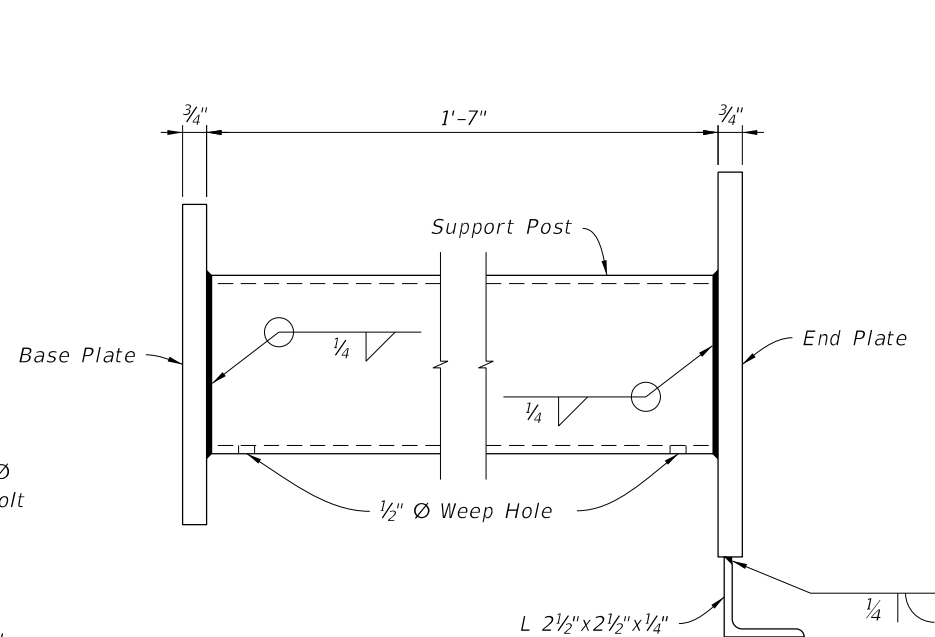

SIGN SUPPORT WELDMENT DETAIL

ANCHOR BOLT NOTES:

1. Existing Traffic Railings:

Locate existing conduit prior to drilling. Adjust placement as necessary to avoid existing conduit. Base plate must be flush with back of traffic railing. Maintain a minimum cover 2" from face of traffic railing to tip of Adhesive Anchor.

For concrete parapets less than 10" thick, through bolt 3/4" Ø Heavy Hex Head Bolts with Nuts and Washers in lieu of Adhesive Bonded Anchors. Bolt heads shall not protrude more than 1 1/2" beyond traffic face of railing.

2. New Traffic Railings:

Tie Anchor Bolts securely and use templates as necessary to maintain bolt spacing.

Optional Couplers are shown for slipforming; keep Anchor Bolt coupler threads free of concrete.

CROSS REFERENCES:

For Base Plate, End Plate & U-Bolt Plate Washer Details see Sheet 1.

C:\projects\standards\struct\11870-2of2.dgn
rd960rh
9:18:07 AM
1/3/2012

LAST REVISION 01/01/12	DESCRIPTION: REVISION	 FDOT DESIGN STANDARDS FY 2012/2013	SINGLE POST BRIDGE MOUNTED SIGN SUPPORT	INDEX NO. 11870	SHEET NO. 2
---------------------------	--------------------------	--	--	---------------------------	-----------------------