

C:\projects\standards\structures\current\ready\release\2012book_draft\06130-1of2.dgn
 12/30/2011 11:47:55 AM rd960rh

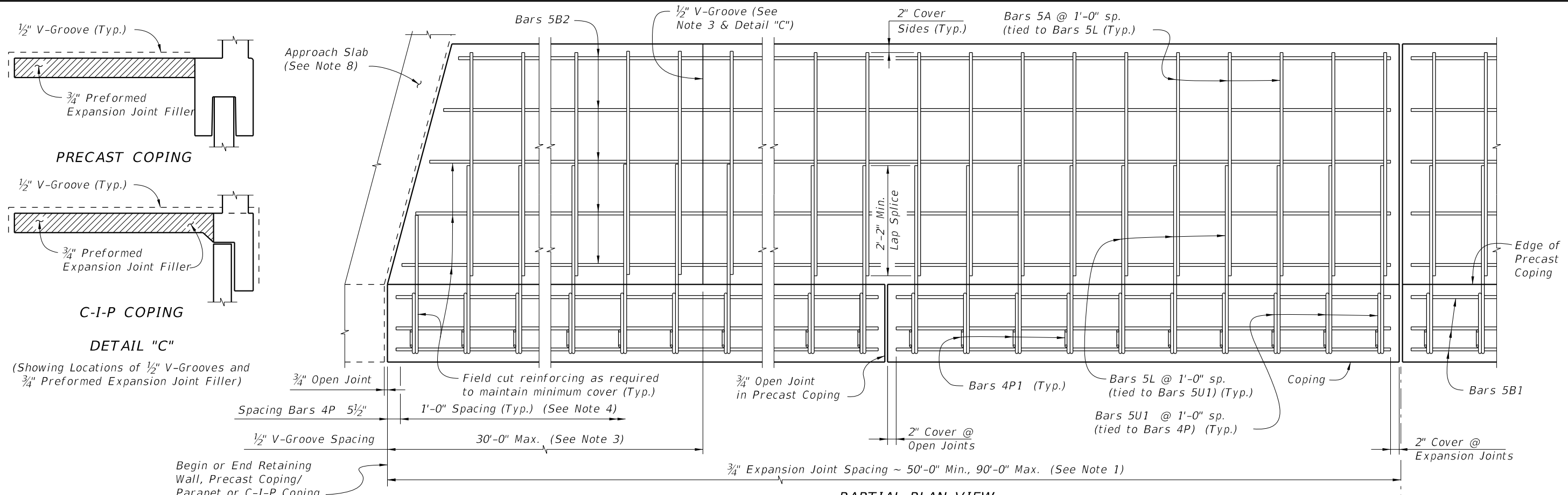

PRECAST COPING/PARAPET AND SIDEWALK NOTES:

1. Provide Class II concrete for slightly aggressive environments or Class IV for moderately or extremely aggressive environments.
2. Construct 3/4" Expansion Joints in sidewalk and C-I-P coping plumb and perpendicular or radial to the Gutter Line. Provide at 90'-0" maximum intervals as shown.
3. Provide and install Preformed Expansion Joint Filler in accordance with Specification Section 932.
4. Construct 1/2" V-Grooves in sidewalk and C-I-P coping plumb and provide at 30'-0" maximum intervals as shown. Space V-Grooves equally between 3/4" Expansion Joints and/or Begin or End Sidewalk. For C-I-P Coping only, V-Groove locations are to coincide with V-Groove locations in the Concrete Parapet.
5. Spacing shown is along the Gutter Line.
6. For Precast Coping only, Dowel Bars 4D are to extend 1'-0" above the top of retaining wall panel. Field cut as necessary to maintain 2" minimum cover to the top of the buildup concrete. See Wall Company Drawings for number and spacing of Dowel Bars 4D.
7. Work this Index with the following:
 Index No. 410 - Concrete Barrier Wall
8. For C-I-P Coping only, work this Index with the following:
 Index No. 820 - Pedestrian/Bicycle Railing.
9. Finish Sidewalks in accordance with Specifications Section 522.
10. The following Indexes contain details of the intersection of the retaining wall at approach slabs:
 Index No. 20900 - Approach Slabs (Flexible Pavement Approaches)
 Index No. 20910 - Approach Slabs (Rigid Pavement Approaches)

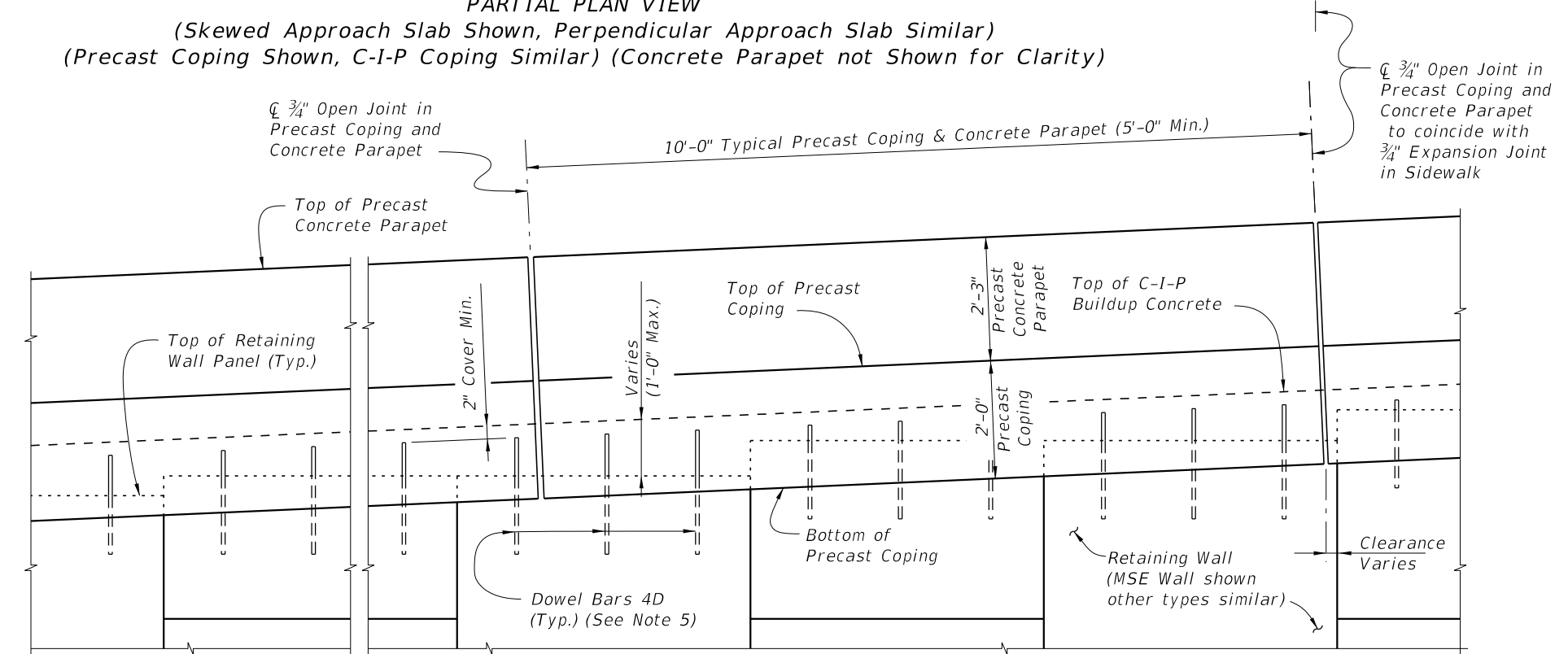

LAST REVISION 01/01/11	REVISION	DESCRIPTION:	 FDOT DESIGN STANDARDS FY 2012/2013	WALL COPING/PARAPET WITH C-I-P SIDEWALK	INDEX NO. 6130	SHEET NO. 1
----------------------------------	-----------------	---------------------	--	--	--------------------------	-----------------------

12/30/2011 11:47:56 AM rd960r/c:\projects\standards\structures\current\ready\4release\2012book_draft\06130-2of2.dgn

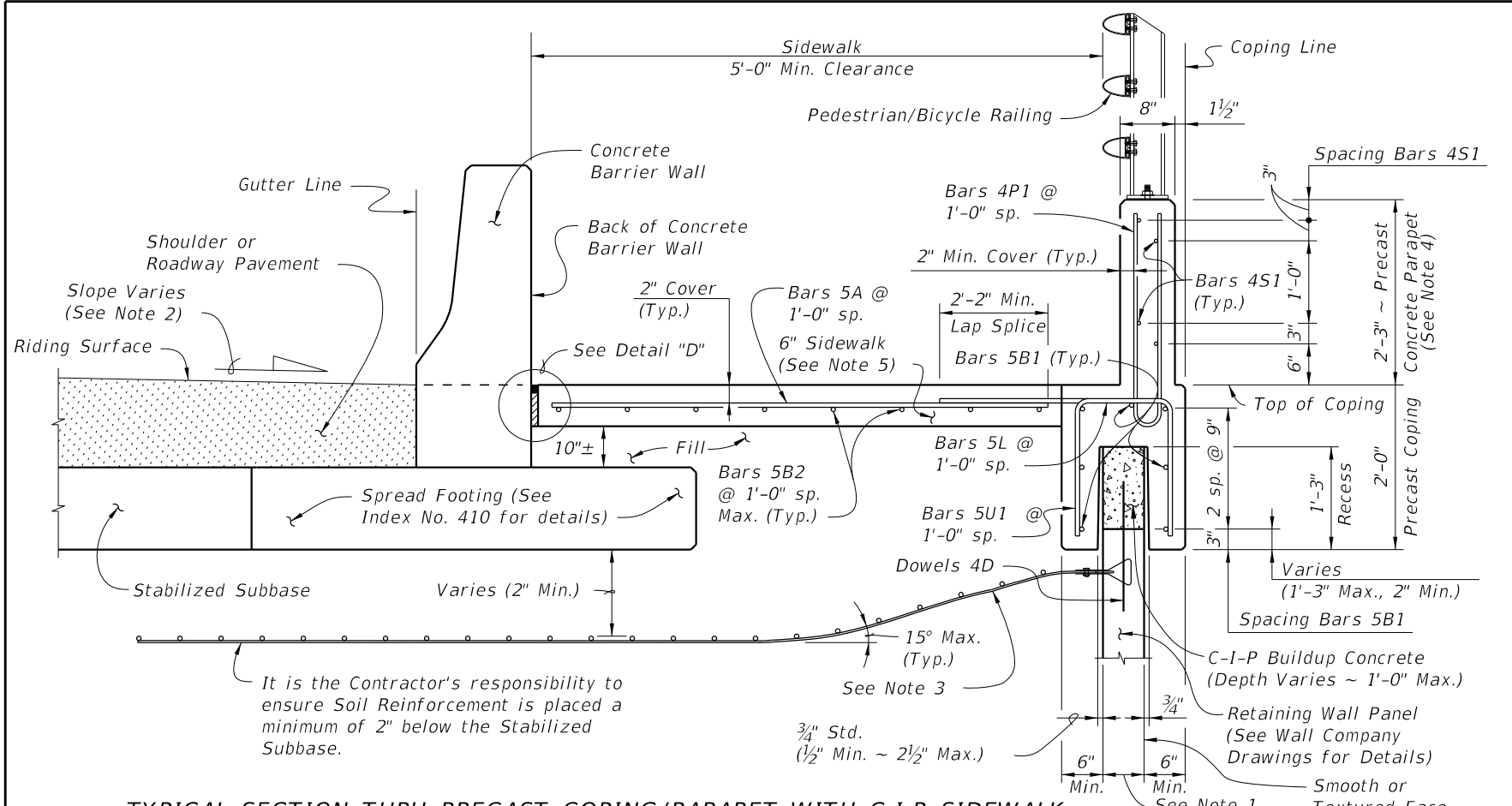

TYPICAL SECTION THRU PRECAST COPING/PARAPET WITH C-I-P SIDEWALK AND RETAINING WALL (MSE Wall Shown, other Wall Types Similar)

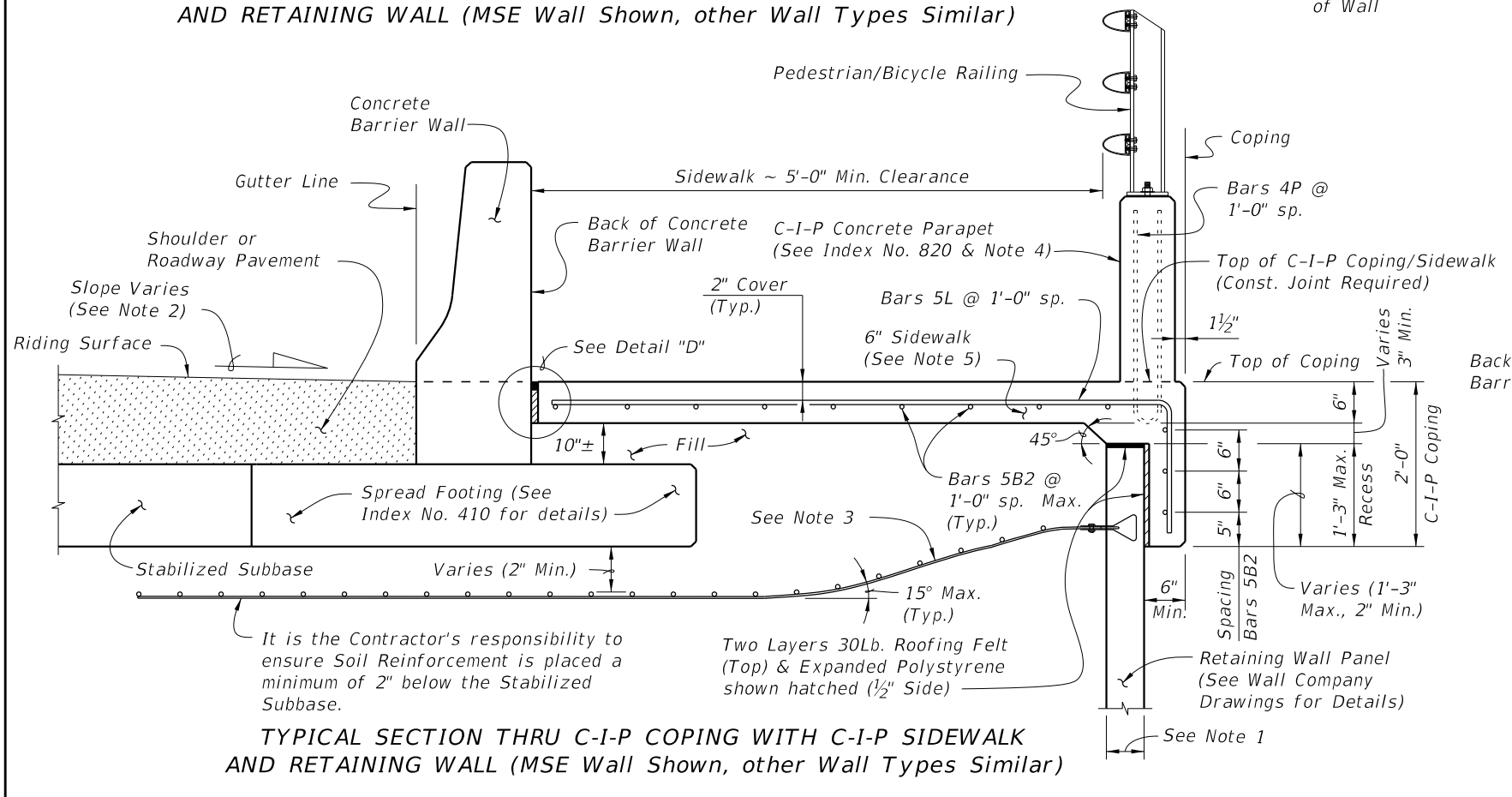

TYPICAL SECTION THRU C-I-P COPING WITH C-I-P SIDEWALK AND RETAINING WALL (MSE Wall Shown, other Wall Types Similar)

REINFORCING STEEL BENDING DIAGRAMS - COPING/PARAPET AND SIDEWALK

BILL OF REINFORCING STEEL			
MARK	SIZE	LENGTH	
		PRECAST COPING	C-I-P COPING
A	5	VARIABLES	N/A
B1	5	9'-6"	N/A
B2	5	AS REQD.	AS REQD.
D	4	2'-0"	N/A
L	5	VARIABLES	VARIABLES
P1	4	5'-5"	N/A
S1	4	9'-6"	N/A
U1	5	VARIABLES	N/A

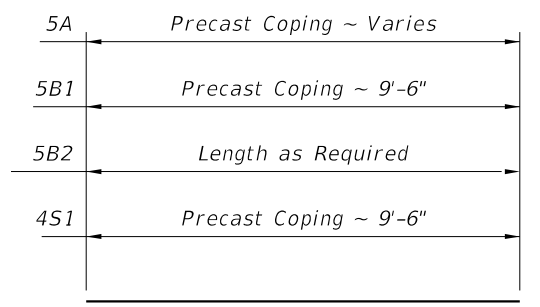

BARS 5A, 5B1, 5B2 & 4S1

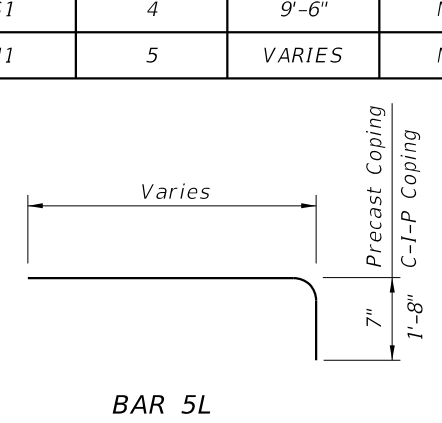

BAR 5L

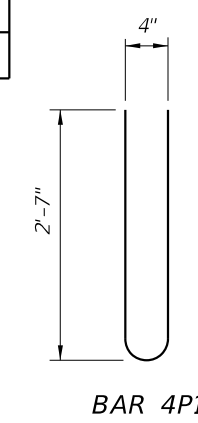

BAR 4P1

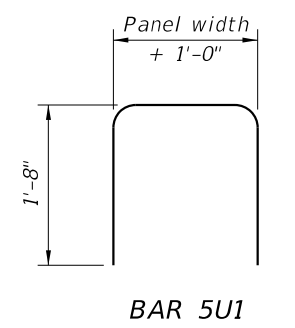

BAR 5U1

- REINFORCING STEEL NOTES:**
1. All bar dimensions in the bending diagrams are out to out.
 2. All reinforcing steel at expansion joints will have a 2" minimum cover.
 3. Lap splices for Bars 5B2 will be a minimum of 2'-2".
 4. For Precast Coping only, lap splice Bars 5L with Bars 5A. Lap splices will be a minimum of 2'-2".
 5. For C-I-P only, see Index No. 820 for Bars 4P and 4S.
 6. The Contractor may use Welded Wire Reinforcement when approved by the Engineer. Welded Wire Reinforcement must conform to ASTM A 497.

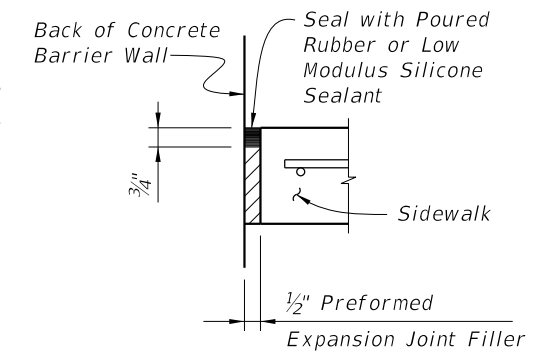

DETAIL "D"

- PRECAST COPING/PARAPET AND SIDEWALK NOTES:**
1. Actual width varies depending on type of Retaining Wall used.
 2. Match Cross Slope of Travel Lane or Shoulder.
 3. Gradually deflect/displace Soil Reinforcement downward as required. Soil Reinforcement is shown deflected downward for illustrative purposes only and is not to scale. See Wall Company Drawings for details.
 4. Concrete Parapet shown, Concrete Pedestrian/Bicycle Railing (Index No. 825 & 826) similar. Complete details and dimensions of Concrete Pedestrian/Bicycle Railing are required in the Shop Drawings.
 5. Match cross slope of connecting sidewalk or as shown in the Wall Control Drawings.